

Errata

Title & Document Type: 6111A DC Power Supply Operating and Service Manual

Manual Part Number: 06111-90001

Revision Date: November 1966

About this Manual

We've added this manual to the Agilent website in an effort to help you support your product. This manual provides the best information we could find. It may be incomplete or contain dated information, and the scan quality may not be ideal. If we find a better copy in the future, we will add it to the Agilent website.

HP References in this Manual

This manual may contain references to HP or Hewlett-Packard. Please note that Hewlett-Packard's former test and measurement, life sciences, and chemical analysis businesses are now part of Agilent Technologies. The HP XXXX referred to in this document is now the Agilent XXXX. For example, model number HP8648A is now model number Agilent 8648A. We have made no changes to this manual copy.

Support for Your Product

Agilent no longer sells or supports this product. You will find any other available product information on the Agilent Test & Measurement website:

www.agilent.com

Search for the model number of this product, and the resulting product page will guide you to any available information. Our service centers may be able to perform calibration if no repair parts are needed, but no other support from Agilent is available.



Agilent Technologies

DC POWER SUPPLY
STB SERIES, MODEL 6111A
SERIAL NUMBER PREFIX 6E

Printed: November, 1966
Ⓜ Stock Number: 06111-90001

TABLE OF CONTENTS

Section	Page No.	Section	Page No.
I GENERAL INFORMATION	1-1	IV PRINCIPLES OF OPERATION	4-1
1-1. Description	1-1	4-1. Overall Block Diagram, Discussion	4-1
1-6. Specifications	1-1	4-6. Simplified Schematic	4-2
1-8. Options	1-1	4-9. Detailed Circuit Analysis	4-3
1-10. Accessories	1-2	4-10. Series Regulator	4-3
1-12. Instrument Identification	1-2	4-12. Constant Voltage Input Circuit	4-3
1-15. Ordering Additional Manuals	1-2	4-18. Driver and Error Amplifier	4-3
II INSTALLATION	2-1	4-20. Current Limit Circuit	4-3
2-1. Initial Inspection	2-1	4-22. Oven Control Circuit	4-3
2-3. Mechanical Check	2-1	4-24. Reference Circuit	4-4
2-5. Electrical Check	2-1	4-28. Meter Circuit	4-4
2-7. Installation Data	2-1	V MAINTENANCE	5-1
2-9. Location	2-1	5-1. Introduction	5-1
2-11. Power Requirements	2-1	5-3. General Measurement Techniques	5-1
2-14. 220 Volt Operation	2-1	5-8. Test Equipment Required	5-1
2-16. Cable	2-1	5-10. Performance Test	5-3
2-19. Mounting	2-2	5-12. Rated Output and Meter Accuracy	5-3
2-23. Repackaging for Shipment	2-3	5-15. Load Regulation (Front Terminals)	5-4
III OPERATING INSTRUCTIONS	3-1	5-17. Line Regulation (Front Terminal)	5-4
3-1. Operating Controls and Indicators	3-1	5-19. Ripple and Noise	5-4
3-3. Operating Modes	3-1	5-21. Transient Recovery Time	5-5
3-5. Normal Operating Mode	3-1	5-23. Output Impedance	5-5
3-7. Constant Voltage	3-1	5-25. Current Limit	5-6
3-9. Current Limit	3-1	5-27. Troubleshooting	5-6
3-11. Connecting Load	3-2	5-29. Trouble Analysis	5-6
3-14. Operation of Supply Beyond Rated Output	3-2	5-37. Repair and Replacement	5-8
3-16. Optional Operating Modes	3-2	5-39. Adjustment and Calibration	5-11
3-17. Remote Programming, Constant Voltage	3-2	5-41. Meter Zero	5-11
3-24. Remote Resistance Programming, Current Limit	3-3	5-43. Voltmeter Tracking	5-11
3-27. Remote Sensing	3-3	5-45. Ammeter Tracking	5-12
3-32. Series Operation	3-4	5-47. Constant Voltage Programming Current	5-12
3-36. Parallel Operation	3-5	VI REPLACEABLE PARTS	6-1
3-38. Auto-Tracking Operation	3-5	6-1. Introduction	6-1
3-42. Special Operating Considerations	3-5	5-4. Ordering Information Reference Designators Abbreviations Manufacturers	6-1
3-43. Pulse Loading	3-5	6-8. Code List of Manufacturers Parts List Table	6-2
3-45. Output Capacitance	3-6		6-5
3-48. Reverse Voltage Loading	3-6		
3-50. Reverse Current Loading	3-6		
3-52. Multiple Loads	3-6		

TABLE OF CONTENTS (CONTINUED)

LIST OF TABLES

Table	Page No.	Table	Page No.
1-1 Specifications	1-3	5-5 Common Troubles	5-8
5-1 Test Equipment Required	5-2	5-6 Selected Semiconductor Characteristics	5-10
5-2 Reference Circuit Troubleshooting	5-6	5-7 Checks and Adjustments After Replacement of Semiconductor Devices	5-10
5-3 High Output Voltage Troubleshooting	5-7	5-8 Calibration Adjustment Summary	5-11
5-4 Low Output Voltage Troubleshooting	5-7		

LIST OF ILLUSTRATIONS

Figure	Page No.	Figure	Page No.
1-1 DC Power Supply	1-v	3-10 Auto-Tracking, Two and Three Units	3-5
2-1 Input Transformer Primary Connections	2-1	4-1 Overall Block Diagram	4-1
2-2 Rack Mounting, Two Units	2-2	4-2 Simplified Schematic	4-2
2-3 Rack Mounting, One Unit	2-2	4-3 Meter Circuit, Simplified Schematic	4-4
3-1 Front Panel Controls and Indicators	3-1	5-1 Front Panel Terminal Connections	5-1
3-2 Normal Strapping Pattern	3-1	5-2 Output Current Measurement Technique	5-1
3-3 Remote Resistance Programming (Constant Voltage)	3-2	5-3 Differential Voltmeter Substitute, Test Setup	5-3
3-4 Remote Voltage Programming (Constant Voltage)	3-2	5-4 Output Current, Test Setup	5-3
3-5 Remote Resistance Programming (Current Limit)	3-3	5-5 Load Regulation, Test Setup	5-4
3-6 Remote Sensing	3-3	5-6 Ripple and Noise, Test Setup	5-4
3-7 Normal Series Connections	3-4	5-7 Transient Recovery Time, Test Setup	5-5
3-8 Auto-Series, Two and Three Units	3-4	5-8 Transient Recovery Time, Waveforms	5-5
3-9 Normal Parallel	3-5	5-9 Output Impedance, Test Setup	5-5
		5-10 Servicing Printed Wiring Boards	5-9

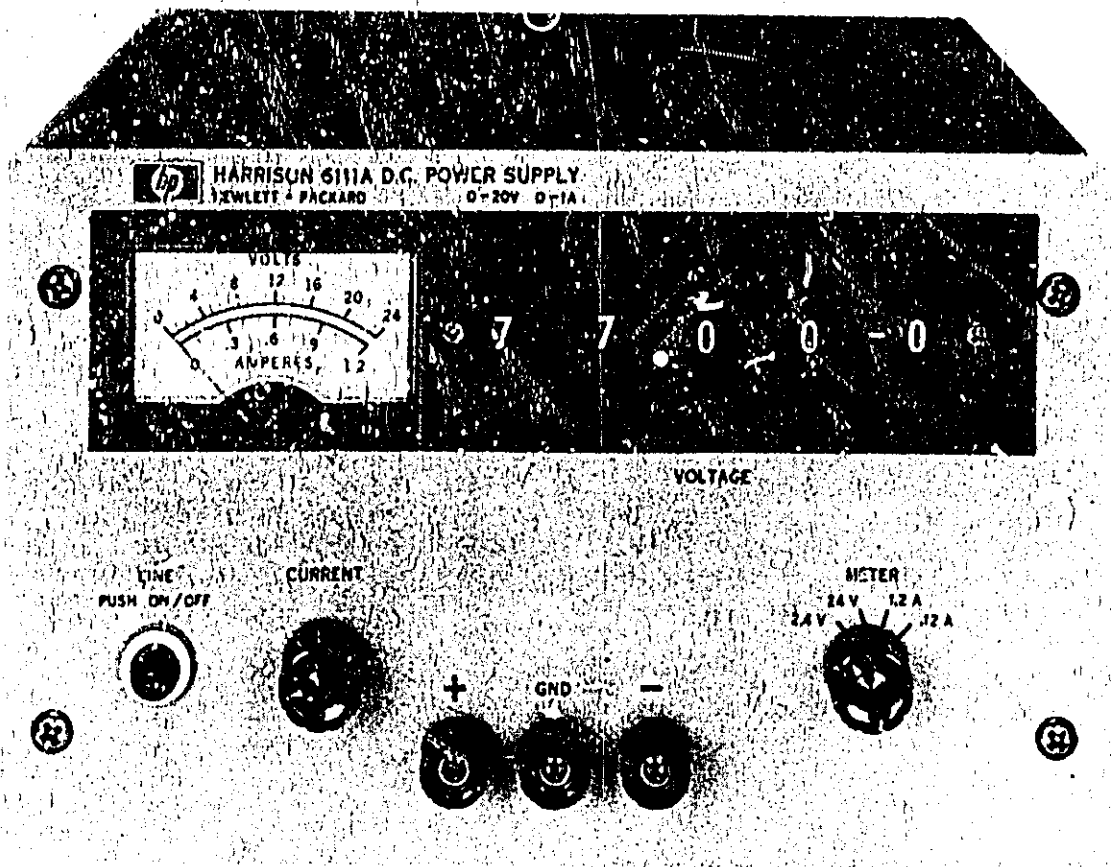

Figure 1-1. DC Power Supply, Model 6111A

SECTION I
GENERAL INFORMATION

1-1 DESCRIPTION

1-2 The STB Series of power supplies is designed for applications requiring extreme stability, regulation, and insensitivity to ambient temperature variations. The supply is completely transistorized (all-silicon) and is suitable for either bench or relay rack operation. The accurate programming coefficient allows the supply to be used as a 0.1% calibrator, or as a voltage reference source. It is a Constant Voltage / Current Limiting supply that will furnish full rated output voltage at the maximum rated output current or can be continuously adjusted throughout the output range. The front panel CURRENT controls can be used to establish the output current limit (overload or short circuit) when the supply is used as a constant voltage source and the VOLTAGE controls can be used to establish the voltage limit (ceiling) when the supply is used as a constant current source.

1-3 The power supply has both front and rear terminals. Either the positive or negative output terminal may be grounded or the power supply can be operated floating at up to a maximum of 300 volts off ground.

1-4 A single meter is used to measure either output voltage or output current in one of two ranges. The voltage or current ranges are selected by a METER switch on the front panel.

1-5 The programming terminals located at the rear of the unit allow ease in adapting to the many operational capabilities of the power supply. A brief description of these capabilities is given below:

a. Remote Programming

The power supply may be programmed from a remote location by means of an external voltage source or resistance.

b. Remote Sensing

The degradation in regulation which would occur at the load because of the voltage drop in the load leads can be reduced by using the power supply in the remote sensing mode of operation.

c. Series and Auto-Series Operation

Power Supplies may be used in series when a higher output voltage is required in the

voltage mode of operation or when greater voltage compliance is required in the constant current mode of operation. Auto-Series operation permits one knob control of the total output voltage from a "master" supply.

d. Parallel Operation

The power supply may be operated in parallel with a similar unit when greater output current capability is required.

e. Auto-Tracking

The power supply may be used as a "master" supply, having control over one (or more) "slave" supplies that furnish various voltages for a system.

1-6 SPECIFICATIONS

1-7 Detailed Specifications for the power supply are given in Table 1-1.

1-8 OPTIONS

1-9 Options are factory modifications of a standard instrument that are requested by the customer. A typical option is replacing the front panel voltage and current controls with ten-turn voltage and current decadal controls. The following options are available on the instrument covered by this manual. Where applicable, detailed coverage of options is included throughout the manual.

Option No. Description

06

Overvoltage Protection "Crowbar": A completely separate circuit for protecting delicate loads against power supply failure or operator error. This independent device monitors the output voltage and within 10 μ sec impose a virtual short-circuit (crowbar) across the power supply output if the preset overvoltage margin is exceeded. When Option 06 is requested by the customer, Model 6916A is attached to the rear of the power supply at the factory.

Overvoltage Margin: 1 to 4 volts, screwdriver adjustable.

Power Requirement: 15ma continuous drain from power supply being protected.

Size: Add 5 inches to power supply depth dimension.

Weight: Add 2 lbs. net.

NOTE

Detailed coverage of Option 06 is included in an addendum entitled, Model 6916A Overvoltage Protector. The addendum is included at the rear of manuals that support power supplies that have been modified for Option 06.

- 28 Rewire for 230V Input: Supply as normally shipped is wired for 115VAC input. Option 28 consists of reconnecting the input transformer for 230VAC operation.

1-10 ACCESSORIES

1-11 The accessories listed in the following may be ordered with the power supply or separately from the local Hewlett-Packard field sales office (refer to list at rear of manual for addresses).

<u>Part No.</u>	<u>Description</u>
C05	.8" Black Handle that can be attached to side of supply.
14513A	Rack Kit for mounting one 3½"-high supply (Refer to Section II for details).
14515A	Rack Kit for mounting one 5¼"-high supply (Refer to Section II for details).

<u>Part No.</u>	<u>Description</u>
14523A	Rack Kit for mounting two 3½"-high supplies (Refer to Section II for details).
14525A	Rack Kit for mounting two 5¼"-high supplies (Refer to Section II for details).

1-12 INSTRUMENT IDENTIFICATION

1-13 Hewlett-Packard power supplies are identified by a three-part serial number tag. The first part is the power supply model number. The second part is the serial number prefix, which consists of a number-letter combination that denotes the date of a significant design change. The number designates the year, and the letter A through I designates the month, January through December respectively. The third part is the power supply serial number.

1-14 If the serial number prefix on your power supply does not agree with the prefix on the title page of this manual, change sheets are included to update the manual. Where applicable, backdating information is given in an appendix at the rear of the manual.

1-15 ORDERING ADDITIONAL MANUALS

1-16 One manual is shipped with each power supply. Additional manuals may be purchased from your local Hewlett-Packard field office (see list at rear of this manual for addresses). Specify the model number, serial number prefix, and $\text{\textcircled{P}}$ Stock Number provided on the title page.

Table 1-1. Specifications

INPUT:

105-125/210-250VAC, single phase, 48-63 Hz (cps), 0.5A, 52W.

OUTPUT:

0-20 volts at 0-1 ampere.

LOAD REGULATION:

Front terminals: Less than 0.001% plus 200 μ v.

Rear terminals: Less than 0.001% plus 100 μ v.

For an output current change from no load to full load.

LINE REGULATION:

Less than 0.001% output change for any line voltage change within the input rating.

RIPPLE AND NOISE:

At any line voltage and under any load condition within rating.

Less than 100 μ v peak-to-peak.

Less than 40 μ v rms.

TEMPERATURE COEFFICIENT:

After 30 minutes warm-up

Front panel control or remote programming:

Less than 0.001% plus 10 μ v per degree Centigrade.

STABILITY:

Total drift after 30 minutes warm-up and with less than $\pm 3^{\circ}\text{C}$ ambient temperature variation:

Front panel control or remote programming:

Less than 0.01% plus 100 μ v for 8 hours.

Less than 0.012% plus 120 μ v for one month.

TEMPERATURE RANGES:

Operating: 0 to 50 $^{\circ}\text{C}$. Storage: -20 to +85 $^{\circ}\text{C}$.

OUTPUT IMPEDANCE:

Less than 0.002 ohms from DC to 100 Hz.

Less than 0.02 ohms from 100 Hz to 1 KHz.

Less than 0.5 ohms from 1 KHz to 100 KHz.

Less than 3 ohms from 100 KHz to 1 MHz.

TRANSIENT RECOVERY TIME:

Less than 50 microseconds for output recovery to within 10 millivolts of the nominal output voltage following a full load current change. Less than 100 microseconds for output recovery to within load regulation specification.

OVERLOAD PROTECTION:

A continuously variable current limit circuit protects the power supply for all overloads including a direct short placed across the output terminals.

METER:

Front panel meter and switch select 0-2.5V/0-25V and 0-120ma/0-1.2A scales.

OUTPUT CONTROLS:

An in-line 5-digit (thumbwheel) voltage programmer permits control of the output voltage with an accuracy of 0.1% plus 1mv of the output voltage. Resolution is 100 μ v. A single turn front panel pot permits the current limit setting to be varied continuously from zero to a value slightly in excess of the full current rating.

OUTPUT TERMINALS:

Three "five-way" output posts are provided on the front panel and an output barrier strip is located on the rear of the chassis. All power supply output terminals are isolated from the chassis and either the positive or negative terminal may be connected to the chassis through a separate ground terminal located on the output terminal strip.

ERROR SENSING:

Error sensing is automatically accomplished at the front terminals if the load is attached to the front terminals or at the rear terminals if the load is attached to the rear terminals. Provision is also included on the rear terminal strip for remote error sensing.

REMOTE PROGRAMMING:

Remote programming of the output voltage is made available at the rear terminals. The programming coefficient is 1000 ohms per volt with an accuracy of 0.1% plus 1 millivolt. The current limit may also be set remotely by means of a resistance, 1000 ohms corresponding approximately to full output current.

COOLING:

Convection cooling is employed. The supply has no moving parts.

SIZE:

5-1/4" H x 8-1/2" W x 12-5/8" D. Two units can be mounted side by side to take up the same space as a standard 5-1/4" x 19" relay rack mounting.

WEIGHT: 11 lbs. net, 15 lbs. shipping.

FINISH: Light gray front panel with dark gray case.

POWER CORD:

A 3-wire, 5-foot power cord is provided with each unit.

SECTION II INSTALLATION

2-1 INITIAL INSPECTION

2-2 Before shipment, this instrument was inspected and found to be free of mechanical and electrical defects. As soon as the instrument is unpacked, inspect for any damage that may have occurred in transit. Save all packing materials until the inspection is completed. If damage is found, proceed as described in the Claim for Damage in Shipment section of the Warranty at the rear of this manual.

2-3 MECHANICAL CHECK

2-4 This check confirms that there are no broken knobs or connectors, that the cabinet and panel surfaces are free of dents and scratches, and that the meters are not scratched or cracked.

2-5 ELECTRICAL CHECK

2-6 The instrument should be checked against its electrical specifications. Section V includes an "in-cabinet" performance check to verify proper instrument operation.

2-7 INSTALLATION DATA

2-8 The instrument is shipped ready for bench operation. It is only necessary to connect the instrument to a source of power and it is ready for operation.

2-9 LOCATION

2-10 This instrument is air cooled. Sufficient space should be provided around the instrument to permit free flow of cooling air along the sides and to the rear. It should be used in an area where the ambient temperature does not exceed 50°C (122°F).

2-11 POWER REQUIREMENTS

2-12 This power supply may be operated from either a 115 or 230 volt, 48-63 cps power source. The unit, as shipped from the factory, is wired for 115V operation.

2-13 The input power required when operating at full load from a 115 volt, 60 cycle power source is 45 watts and 0.5 amperes.

2-14 230 VOLT OPERATION

2-15 Normally, the windings of the input transformer are connected in parallel for operation from

a 115 volt source. To convert the power supply for operation from a 230 volt source, the power transformer windings must be connected in series. The windings are connected in series as follows: (Refer to Figure 2-1)

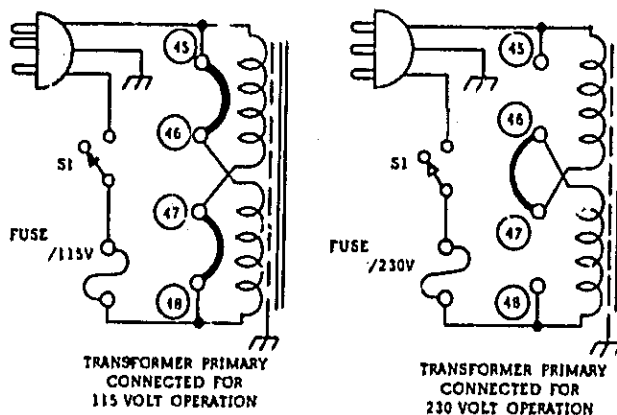

Figure 2-1. Input Transformer Primary Connections

a. Unplug the line cord and remove the top and bottom covers from the case. (This is done by removing the four screws which hold each cover to the side frames.)

b. With a sharp knife or razor blade, cut the printed wiring between test points 45 and 46 and also between 47 and 48 on the printed circuit board. These are shown on the overall schematic and are labeled on the printed circuit board.

c. Connect a jumper wire between 46 and 47.

d. Replace the fuse with a $\frac{1}{2}$ ampere 230 volt fuse. Replace covers and operate unit normally.

2-16 POWER CABLE

2-17 To protect operating personnel, the National Electrical Manufacturers Association (NEMA) recommends that the instrument panel and cabinet be grounded. This instrument is equipped with a three conductor power cable. The third conductor is the ground conductor and when the cable is plugged into an appropriate receptacle, the instrument is grounded. The offset pin on the power cable three-prong connector is the ground connection.

2-18 To preserve the protection feature when operating the instrument from a two-contact outlet, use a three-prong to two-prong adaptor and connect the green lead on the adaptor to ground.

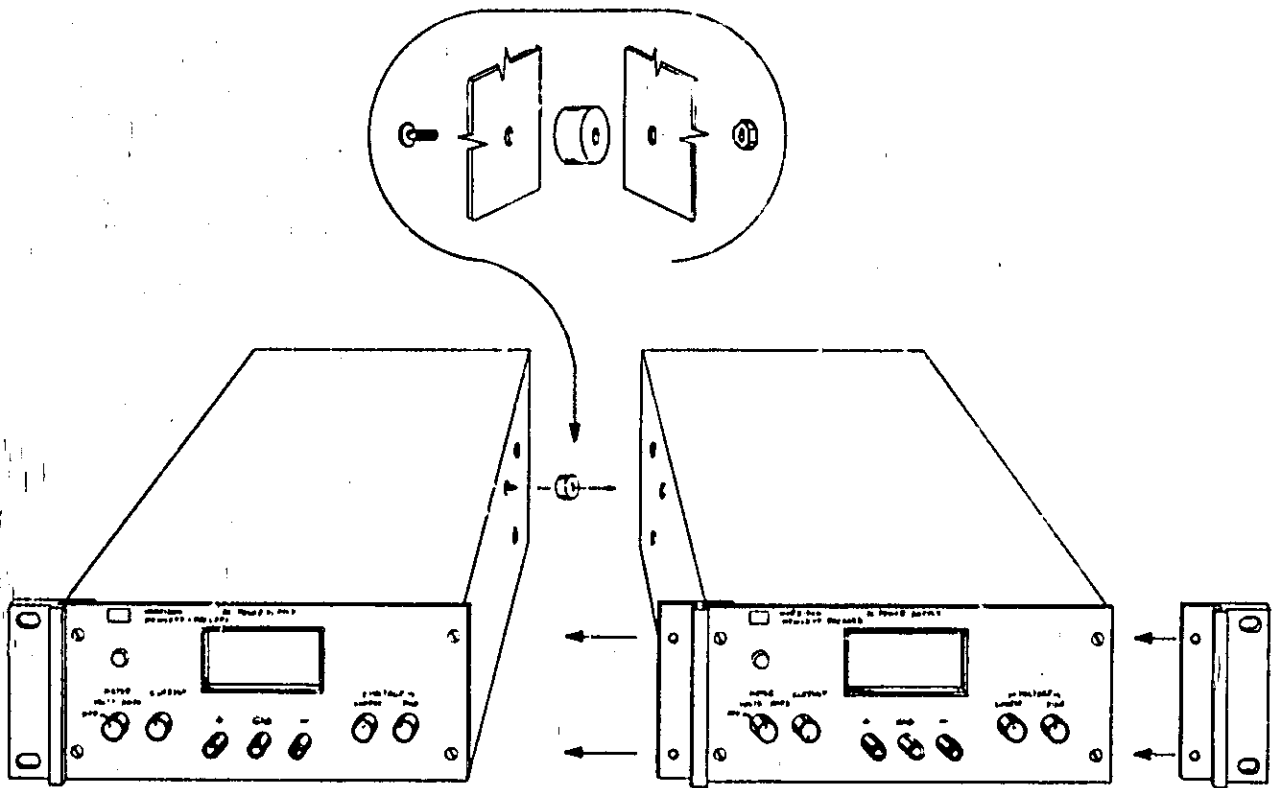

Figure 2-2. Rack Mounting, Two Units

2-19 RACK MOUNTING

2-20 This instrument may be rack mounted in a standard 19 inch rack panel either alongside a similar unit or by itself. Figures 2-2 and 2-3 show how both types of installations are accomplished.

2-21 To mount two units side-by-side, proceed as follows:

- a. Remove the four screws from the front panels of both units.
- b. Slide rack mounting ears between the front panel and case of each unit.
- c. Slide combining strip between the front panels and cases of the two units.

d. After fastening rear portions of units together using the bolt, nut, and spacer, replace panel screws.

2-22 To mount a single unit in the rack panel, proceed as follows:

- a. Bolt rack mounting ears, combining straps, and angle brackets to each side of center spacing panels. Angle brackets are placed behind combining straps as shown in Figure 2-3.
- b. Remove four screws from front panel of unit.
- c. Slide combining strips between front panel and case of unit.
- d. Bolt angle brackets to front sides of case and replace front panel screws.

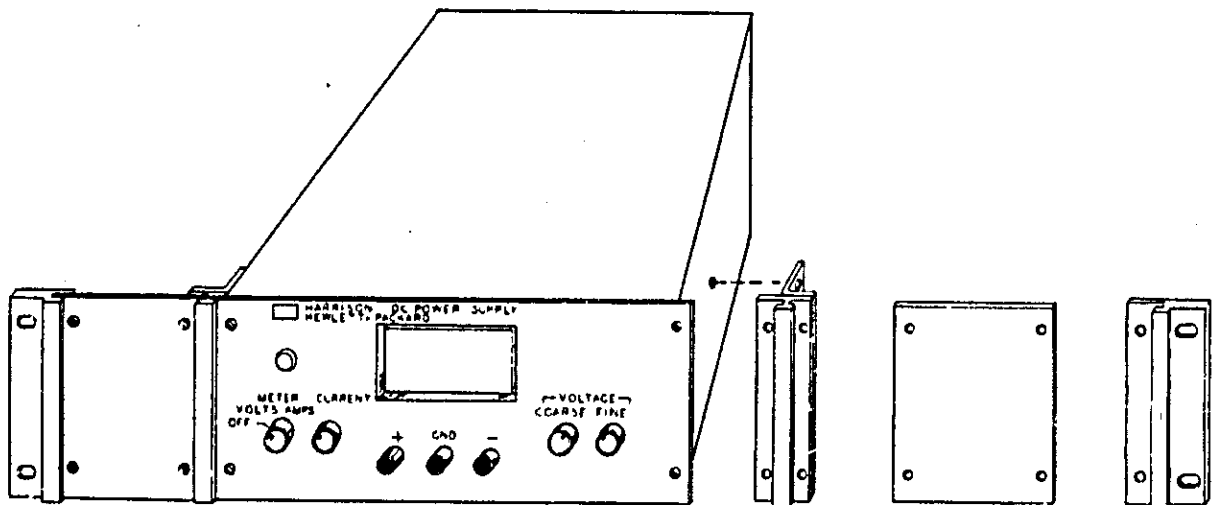

Figure 2-3. Rack Mounting, One Unit

2-23 REPACKAGING FOR SHIPMENT

2-24 To insure safe shipment of the instrument, it is recommended that the package designed for the instrument be used. The original packaging material is reusable. If it is not available, contact your local Hewlett-Packard field office to

obtain the materials. This office will also furnish the address of the nearest service office to which the instrument can be shipped. Be sure to attach a tag to the instrument which specifies the owner, model number, full serial number, and service required, or a brief description of the trouble.

SECTION III OPERATING INSTRUCTIONS

3-1 OPERATING CONTROLS AND INDICATORS

3-2 The front panel controls and indicators, together with the normal turn-on sequence, are shown in Figures 3-1.

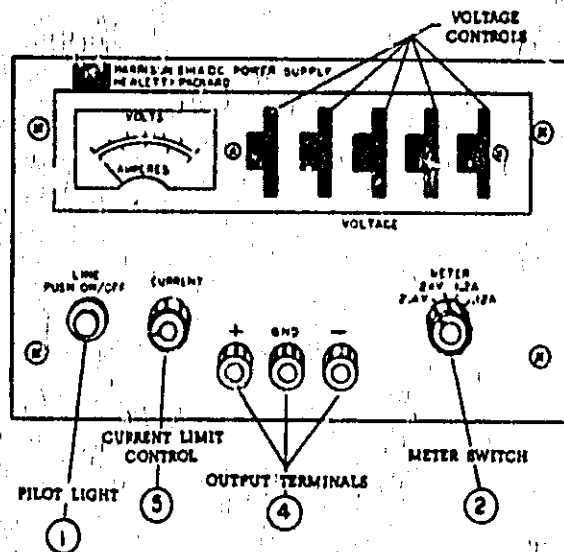

1. PUSH LINE SWITCH TO TURN ON SUPPLY AND OBSERVE THAT LIGHT GOES ON.
2. SET METER SWITCH TO DESIRED VOLTAGE RANGE.
3. ADJUST VOLTAGE CONTROLS UNTIL DESIRED OUTPUT VOLTAGE IS INDICATED ON METER.
4. SHORT CIRCUIT OUTPUT TERMINALS AND SET METER SWITCH TO DESIRED CURRENT RANGE.
5. ADJUST CURRENT CONTROL FOR DESIRED OUTPUT CURRENT.
6. REMOVE SHORT AND CONNECT LOAD TO OUTPUT TERMINALS (FRONT OR REAR).
7. POWER IS REMOVED BY PUSHING THE LINE SWITCH.

Figure 3-1. Front Panel Controls and Indicators

3-3 OPERATING MODES

3-4 The power supply is designed so that its mode of operation can be selected by making strapping connections between particular terminals on the terminal strip at the rear of the power supply. The terminal designations are stenciled in white on the power supply above their respective terminals. Although the strapping patterns illustrated in this section show the negative terminal grounded, the operator can ground either terminal or operate the power supply up to 300 vdc off ground (floating). The following paragraphs describe the procedures for utilizing the various operational capabilities of the power supply. A more theoretical description is contained in a power supply Application Manual and in various Tech. Letters published by the Harrison Division. Copies of these can be obtained from your local Hewlett-Packard field office.

3-5 NORMAL OPERATING MODE

3-6 The power supply is normally shipped with its rear terminal strapping connections arranged for Constant Voltage / Current Limiting, local sensing, local programming, single unit mode of operation. This strapping pattern is illustrated in Figure 3-2. The operator selects either a constant voltage or current limited output using the front panel controls (local programming, no strapping changes are necessary).

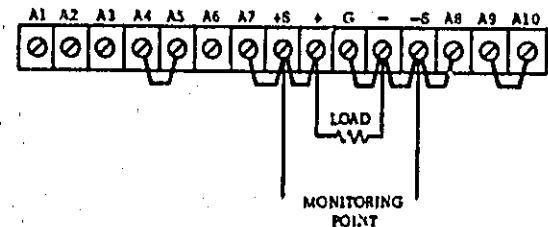

Figure 3-2. Normal Strapping Pattern

3-7 CONSTANT VOLTAGE

3-8 To select a constant voltage output, proceed as follows:

- a. Turn-on power supply and adjust VOLTAGE controls for desired output voltage (output terminals open).
- b. Short output terminals and adjust CURRENT controls for maximum output current allowable (current limit), as determined by load conditions. If a load change causes the current limit to be exceeded, the power supply will automatically cross-over to constant current output at the preset current limit and the output voltage will drop proportionately. In setting the current limit, allowance must be made for high peak current which can cause unwanted cross-over. (Refer to Paragraph 3-43.)

3-9 CURRENT LIMIT

3-10 To select a current limit output, proceed as follows:

- a. Short output terminals and adjust CURRENT controls for desired output current.
- b. Open output terminals and adjust VOLTAGE controls for maximum output voltage allowable (voltage limit), as determined by load conditions. If a load change causes the voltage limit to be exceeded, the power supply will automatically cross-over to constant voltage output at the preset voltage limit and the output current will drop proportionately. In setting the voltage limit, allowance must be made for high peak voltages which can cause unwanted crossover. (Refer to Paragraph 3-43.)

3-11. CONNECTING LOAD

3-12 Each load should be connected to the power supply output terminals using separate pairs of connecting wires. This will minimize mutual coupling effects between loads and will retain full advantage of the low output impedance of the power supply. Each pair of connecting wires should be as short as possible and twisted or shielded to reduce noise pickup. (If shield is used, connect one end to power supply ground terminal and leave the other end unconnected.)

3-13 If load considerations require that the output power distribution terminals be remotely located from the power supply, then the power supply output terminals should be connected to the remote distribution terminals via a pair of twisted or shielded wires and each load separately connected to the remote distribution terminals. For this case, remote sensing should be used (Paragraph 3-27).

3-14 OPERATION OF SUPPLY BEYOND RATED OUTPUT

3-15 The shaded area on the front panel meter face indicates the amount of output voltage or current that is available in excess of the normal rated output. Although the supply can be operated in this shaded region without being damaged, it cannot be guaranteed to meet all of its performance specifications. However, if the line voltage is maintained above 115 Vac, the supply will probably operate within its specifications.

3-16 OPTIONAL OPERATING MODES

3-17 REMOTE PROGRAMMING, CONSTANT VOLTAGE

3-18 The constant voltage output of the power supply can be programmed (controlled) from a remote location if required. Either a resistance or voltage source can be used for the programming device. The wires connecting the programming terminals of the supply to the remote programming device should be twisted or shielded to reduce noise pick-up. The VOLTAGE controls on the front panel are disabled according to the following procedures.

3-19 Resistance Programming (Figure 3-3). In this mode, the output voltage will vary at a rate determined by the programming coefficient--100.0 ohms per volt (i.e., the output voltage will increase 1 volt for each 1000 ohms added in series with programming terminals). The programming coefficient is determined by the programming current. This current is adjusted to within 0.1% of 1ma at the factory. If greater programming accuracy is required, it may be achieved by changing resistor R16.

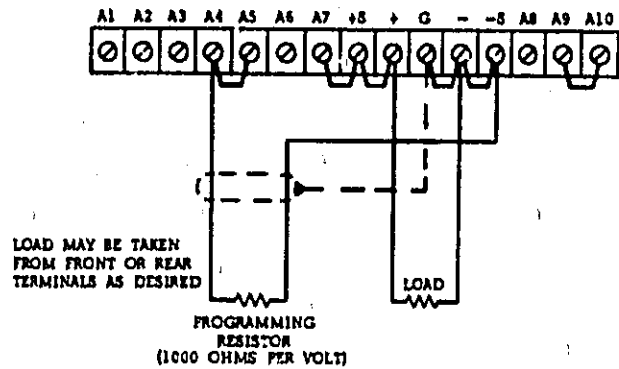

Figure 3-3. Remote Resistance Programming (Constant Voltage)

3-20 The output voltage of the power supply should be zero volts \pm 1 millivolt when zero ohms is connected across the programming terminals. If a zero ohm voltage closer than this is required, it may be achieved by changing resistor R14 as described in Paragraph 5-48.

3-21 To maintain the stability and temperature coefficient of the power supply, use programming resistors that have stable, low noise, and low temperature characteristics (less than 5 ppm per degree Centigrade). A switch can be used in conjunction with various resistance values in order to obtain discrete output voltages. The switch should have make-before-break contacts to avoid momentarily opening the programming terminals during the switching interval.

3-22 Voltage Programming (Figure 3-4). Employ the strapping pattern shown in Figure 3-4 for voltage programming. In this mode, the output voltage will vary in a 1 to 1 ratio with the programming voltage (reference voltage) and the load on the programming voltage source will not exceed 0.5 microampere.

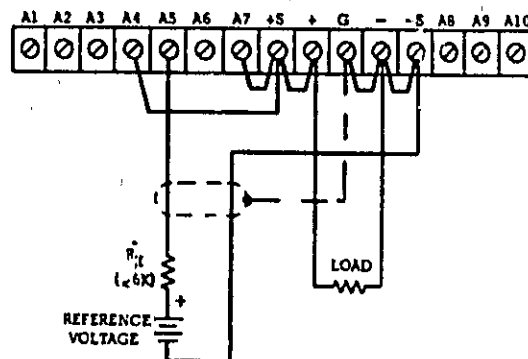

Figure 3-4. Remote Voltage Programming (Constant Voltage)

3-23 The impedance (R_x) looking into the external programming voltage source should be approximately 6000 ohms if the temperature and stability specifications of the power supply are to be maintained.

3-24 REMOTE RESISTANCE PROGRAMMING, CURRENT LIMIT (See Figure 3-5)

3-25 The output current will vary roughly in proportion to the programming resistor. Full current output is obtained with approximately 1000 ohms; however, the exact current setting should be checked by shorting the output terminals and reading the current with the programming resistor in place.

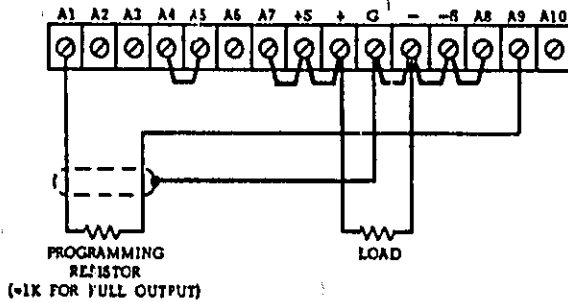

Figure 3-5. Remote Resistance Programming (Current Limit)

3-26 Use stable, low noise, low temperature coefficient (less than 5 ppm/°C) programming resistors to maintain the power supply temperature coefficient and stability specifications. A switch may be used to set discrete values of output current. A make-before-break type of switch should be used since the output current will exceed the maximum rating of the power supply if the switch contacts open during the switching interval.

CAUTION

If the programming terminals (A1 and A9) should open at any time during this mode, the output current will rise to a value that may damage the power supply and/or the load. To avoid this possibility, connect a 1K Ω resistor across the programming terminals and in parallel with a remote programming resistor. Like the programming resistor, the 1K Ω resistor should be of the low noise, low temperature coefficient type.

3-27 REMOTE SENSING (See Figure 3-6)

3-28 Remote sensing is used to maintain good regulation at the load and reduce the degradation of regulation which would occur due to the voltage drop in the leads between the power supply and the load. Remote sensing is accomplished by utilizing the strapping pattern shown in Figure 3-6. The power supply should be turned off before changing strapping patterns. The leads from the +S terminals to the load will carry approximately 1 milliamperes of current, and it is not required that these leads be as heavy as the load leads. However, they must be twisted or shielded to minimize noise pick-up.

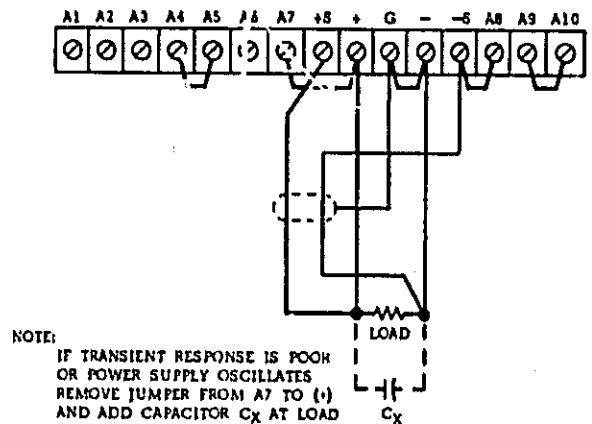

NOTE:
IF TRANSIENT RESPONSE IS POOR
OR POWER SUPPLY OSCILLATES
REMOVE JUMPER FROM A7 TO (+)
AND ADD CAPACITOR C_x AT LOAD

MODEL	6111A	6112A	6116A
C_x	145 μ f 45V	490 μ f 75V	200 μ f 150V

Figure 3-6. Remote Sensing

CAUTION

Observe polarity when connecting the sensing leads to the load.

3-29 Note that it is desirable to minimize the drop in the load leads and it is recommended that the drop not exceed 1 volt per lead if the power supply is to meet its DC specifications. If a larger drop must be tolerated, please consult a Hewlett-Packard field representative.

3-30 The procedure just described will result in a low DC output impedance at the load. If a low AC impedance is required, it is recommended that the following precautions be taken:

- a. Disconnect output capacitor C3, by disconnecting the strap between A7 and (+).

b. Connect a capacitor having similar characteristics (approximately same capacitance, same voltage rating or greater, and having good high frequency characteristics) across the load using short leads.

3-31 Although the strapping patterns shown in Figures 3-3 through 3-5 employ local sensing, note that it is possible to operate a power supply simultaneously in the remote sensing and Constant Voltage/Current Limit remote programming modes.

NOTE

It is necessary to readjust the current limit when the instrument is operated in the remote sensing mode.

3-32 SERIES OPERATION

3-33 Normal Series Connections (Figure 3-7). Two or more power supplies can be operated in series to obtain a higher voltage than that available from a single supply. When this connection is used, the output voltage is the sum of the voltages of the individual supplies. Each of the individual supplies must be adjusted in order to obtain the total output voltage. The power supply contains a protective diode connected internally across the output which protects the supply if one power supply is turned off while its series partner(s) is on.

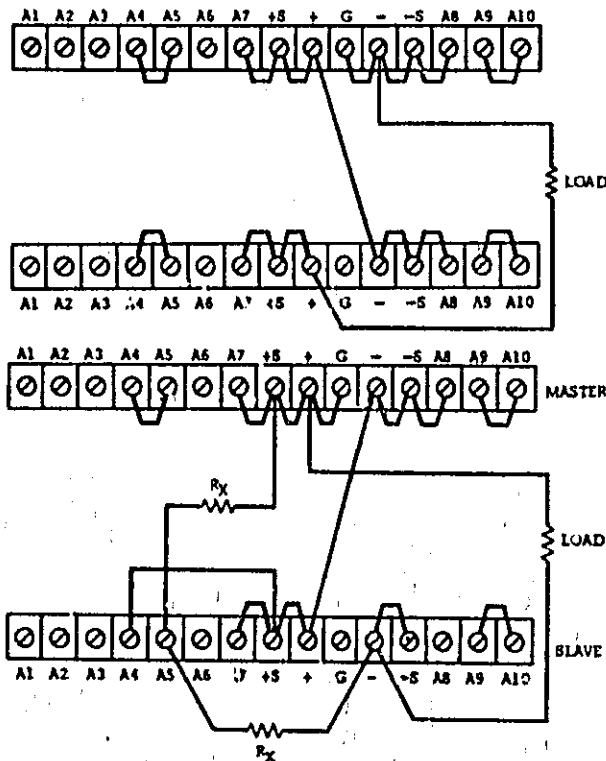

Figure 3-7. Top: Normal Series; Bottom: Auto-Series, Two Units

3-34 Auto-Series Connections (Figure 3-8). The Auto-Series configuration is used when it is desirable to have the output voltage of each of the series connected supplies vary in accordance with the setting of a control unit. The control unit is called the master; the controlled units are called slaves. At maximum output voltage, the voltage of the slaves is determined by the setting of the front panel VOLTAGE control on the master. The master supply must be the most positive supply of the series. The output CURRENT controls of all series units are operative and the current limit is equal to the lowest control setting. If any output CURRENT controls are set too low, automatic crossover to constant current operation will occur and the output voltage will drop. Remote sensing and programming can be used; however, the strapping arrangements shown in the applicable figures show local sensing and programming.

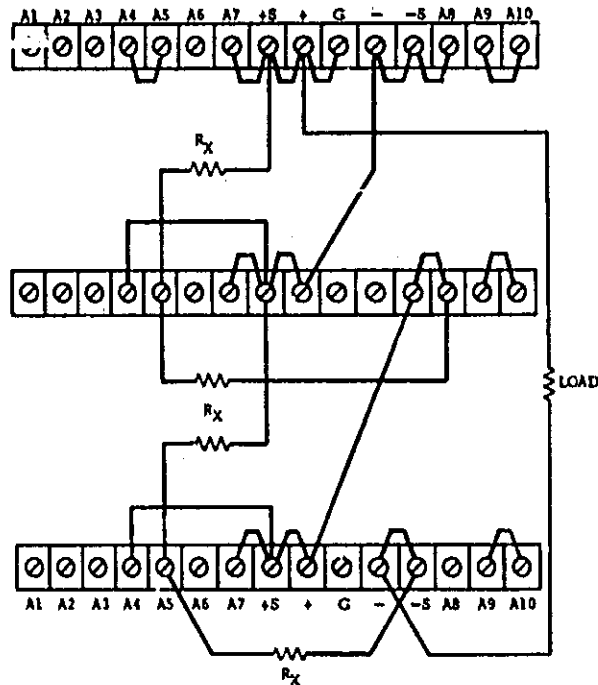

Figure 3-8. Auto-Series, Three Units

3-35 In order to maintain the temperature coefficient and stability specifications of the power supply, the external resistors (R_x) shown in Figure 3-8 should be stable, low noise, low temperature coefficient (less than 5 ppm per degree Centigrade) resistors. The value of each resistor is dependant on the desired output voltage ratings of the master and slave supplies. The value of R_x is this voltage divided by the voltage programming current of the supply, $1/m_a$ ($1/K_p$ where K_p is the voltage programming coefficient).

3-36 PARALLEL OPERATION (Figure 3-9).

3-37 Two or more power supplies can be connected in parallel to obtain a total output current greater than that available from one power supply. The total output current is the sum of the output currents of the individual power supplies. The output CURRENT controls of each power supply can be separately set. The output voltage controls of one power supply should be set to the desired output voltage; the other power supply should be set for a slightly larger output voltage. The supply set to the lower output voltage will act as a constant voltage source; the supply set to the higher output voltage will act as a constant current source, dropping its output voltage until it equals that of the other supply.

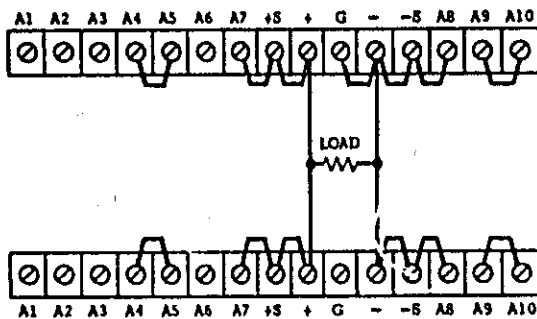

Figure 3-9. Normal Parallel

3-38 AUTO TRACKING OPERATION (See Figure 3-10.)

3-39 This connection is used when it is necessary to provide several voltages, all referred to a common bus, which vary in proportion to the setting of one master instrument. The following constraints must be observed when using this connection.

- The master unit must be a positive voltage source. When several positive sources are used, the master must be the largest voltage unit.
- The external resistors should be stable, low noise, low temperature coefficient resistors if the instruments are to maintain their temperature coefficient and stability specifications.

3-40 The resistor values are determined as follows: Referring to Figure 3-10 for two units,

$$\frac{R_A}{R_B} = \frac{V_{\text{Master}} - V_{\text{Slave}}}{V_{\text{Slave}}}$$

Choosing 10 milliamperes as a reasonable maximum current in the resistors $R_A = 100 (V_{\text{master}} - V_{\text{slave}})$ and $R_B = 100 (V_{\text{slave}})$.

3-41 For several units connected in auto tracking refer to Figure 3-10. R_A and R_B are determined as before. $R_C = 100 (V_{\text{master}} - V_{\text{slave}_2})$, $R_D = 100 (V_{\text{slave}_2})$, etc.

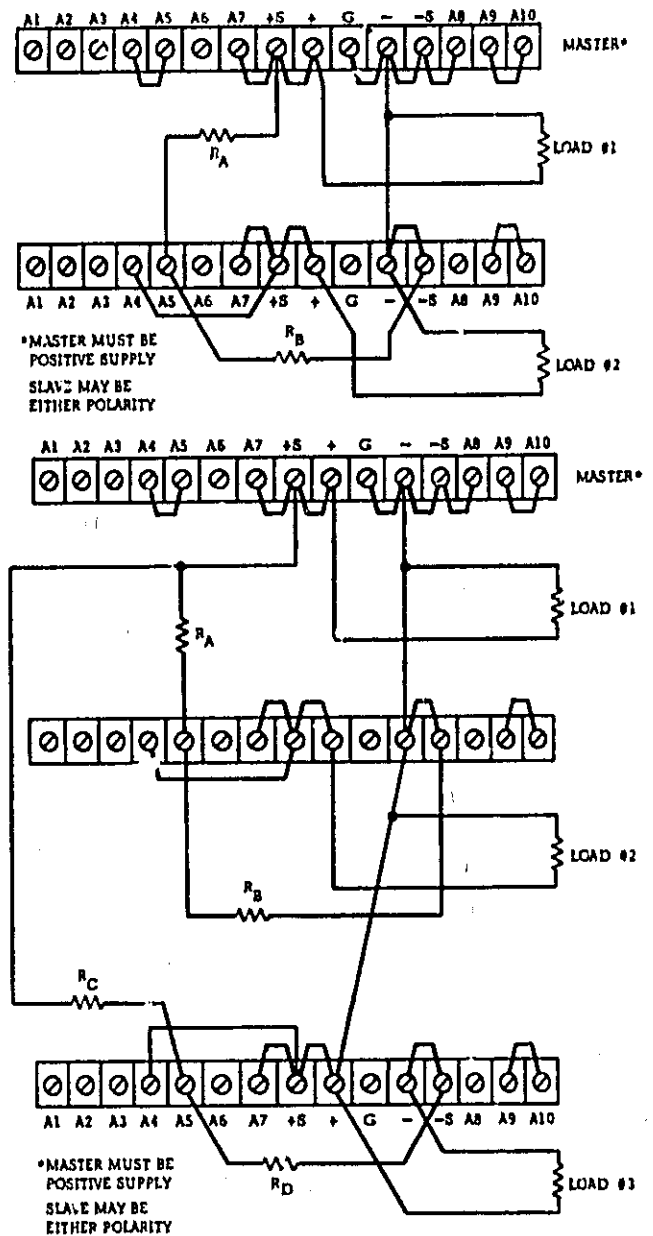

Figure 3-10. Auto-Tracking, Two and Three Units

3-42 SPECIAL OPERATING CONSIDERATIONS

3-43 PULSE LOADING

3-44 The power supply will automatically crossover from constant voltage to constant current operation, or the reverse, in response to an increase (over the preset limit) in the output current or voltage, respectively. Although the preset limit may be set higher than the average output current or voltage, high peak currents or voltages (as occur in pulse loading) may exceed the preset limit and cause crossover to occur. If this crossover limiting is not desired, set the preset limit for the peak requirement and not the average.

3-45 OUTPUT CAPACITANCE

3-46 There is a capacitor (internal) across the output terminals of the power supply. This capacitor helps to supply high-current pulses of short duration during constant voltage operation. Any capacitance added externally will improve the pulse current capability, but will decrease the safety provided by the constant current circuit. A high-current pulse may damage load components before the average output current is large enough to cause the constant current circuit to operate.

3-47 The effects of the output capacitor during constant current operation are as follows:

- a. The output impedance of the power supply decreases with increasing frequency.
- b. The recovery time of the output voltage is longer for load resistance changes.
- c. A large surge current causing a high power dissipation in the load occurs when the load resistance is reduced rapidly.

3-48 REVERSE VOLTAGE LOADING

3-49 A diode is connected across the output terminals. Under normal operating conditions, the diode is reverse biased (anode connected to negative terminal). If a reverse voltage is applied to the out-

put terminals (positive voltage applied to negative terminal), the diode will conduct, shunting current across the output terminals and limiting the voltage to the forward voltage drop of the diode. This diode protects the series transistors and the output electrolytic capacitors.

3-50 REVERSE CURRENT LOADING

3-51 Active loads connected to the power supply may actually deliver a reverse current to the power supply during a portion of its operating cycle. An external source cannot be allowed to pump current into the supply without loss of regulation and possible damage to the output capacitor. To avoid these effects, it is necessary to preload the supply with a dummy load resistor so that the power supply delivers current through the entire operating cycle of the load device.

3-52 MULTIPLE LOADS

3-53 It is imperative that each load taken from the power supply have two separate leads brought back to the power supply output terminals if full advantage is to be taken of the low output impedance of the power supply and if mutual coupling effects between loads are to be avoided.

SECTION IV
PRINCIPLES OF OPERATION

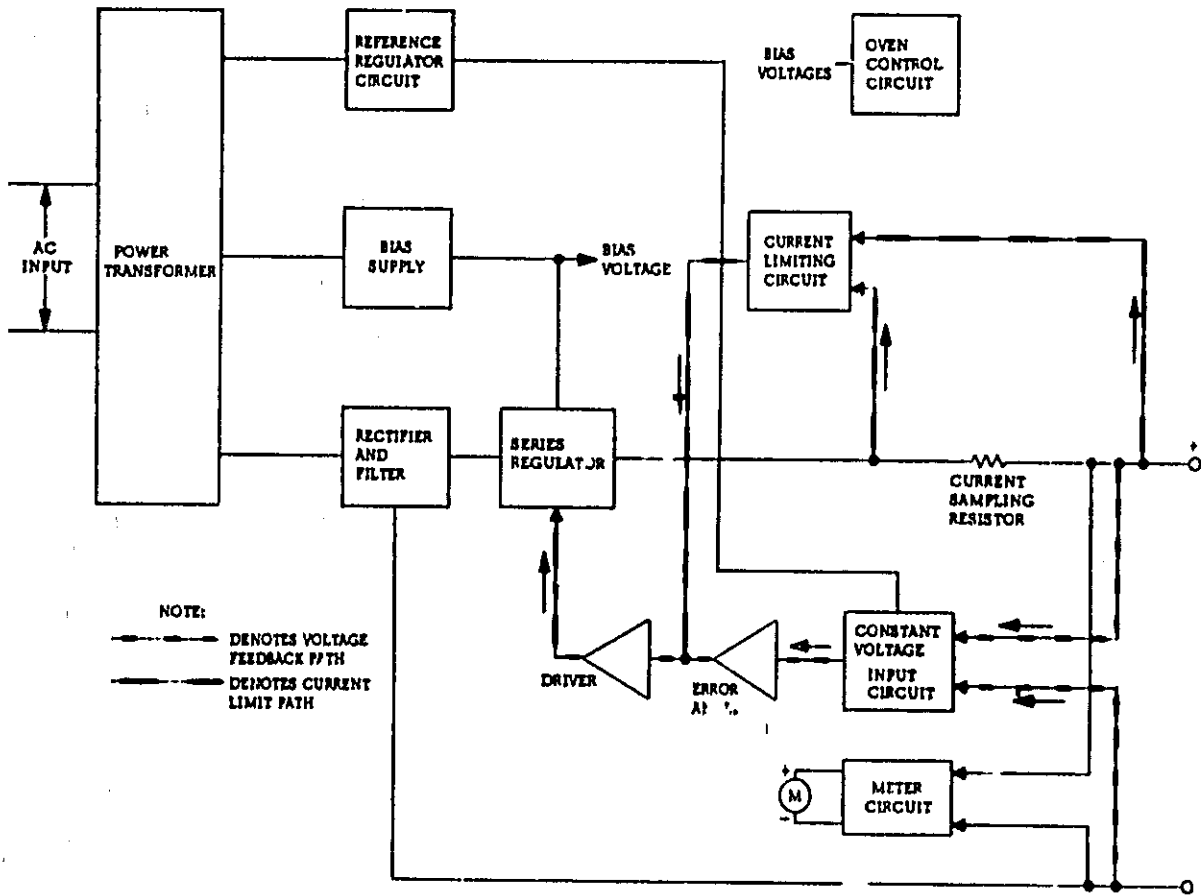

Figure 4-1. Overall Block Diagram

4-1 OVERALL BLOCK DIAGRAM DISCUSSION

4-2 The power supply, figure 4-1, consists of a power transformer, rectifier and filter, series regulator, error amplifier and driver, constant voltage input circuit, current limiting circuit, reference regulator circuit, bias supply, meter circuit, and an oven control circuit.

4-3 The ac input line voltage is reduced to the proper level and coupled to the rectifier and filter. The rectifier-filter converts the ac input to raw dc which is fed to the positive terminal via the regulator and current sampling resistor network. The regulator, part of the feedback loop, is made to alter its conduction to maintain a constant output voltage or limit the output current. The voltage developed across the current sampling resistor network is the input to the current limiting circuit. If the output current that passes through the sampling network exceeds a certain predetermined level, the current limiting circuit applies a feedback signal to the series regulator which alters the regulator's conduction so that the output cur-

rent does not exceed the predetermined current limit.

4-4 The constant voltage input circuit obtains its input by sampling the output voltage of the supply. Any changes in output voltage are detected in the constant voltage input circuit, amplified by the error amplifier and driver, and applied to the series regulator in the correct phase and amplitude to counteract the change in output voltage. The reference regulator circuit provides stable reference voltages which are used by the constant voltage input circuit and the current limiting circuit for comparison purposes. The bias supply furnishes voltages which are used throughout the instrument for biasing purposes. The meter circuit provides indications of output voltage or current in either operating mode.

4-5 An oven houses the temperature sensitive components in the supply to provide a low temperature coefficient which results in excellent stability. The oven control circuit maintains the oven temperature at 65°C.

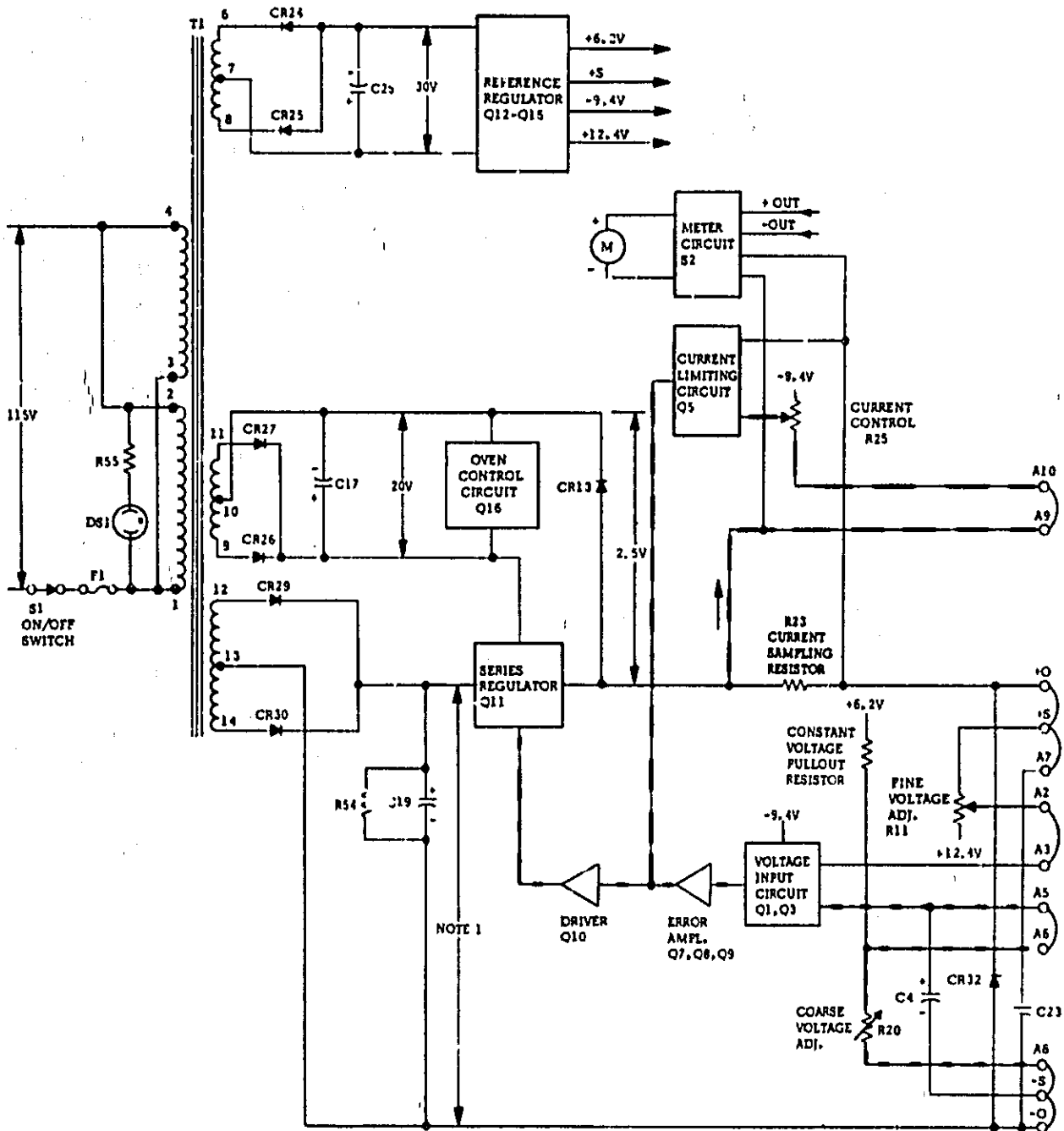

NOTE 1: MAIN SUPPLY OUTPUT VOLTAGES ARE:

MODEL	6101A	6102A	6106A	6111A	6112A	6113A	6115A
VDC	25	60	132	25	60	13	132

Figure 4-2. Simplified Schematic

4-6 SIMPLIFIED SCHEMATIC

4-7 A simplified schematic of the power supply is shown in Figure 4-2. It illustrates the operating controls; the ON-off switch, and the voltage programming controls (R11 and R20). Figure 4-2 also shows the internal sources of bias and reference voltages and their nominal magnitudes with an input of 115 Vac.

4-8 Diode CR32, connected across the output terminals of the power supply, is a protective device which prevents internal damage that might occur if a reverse voltage were applied across the output terminals. Output capacitor, C23, is also connected across the output terminals when the normal strapping pattern shown on Figure 4-2 is employed. Note that this capacitor can be removed if an increase in the programming speed is desired.

4-9 DETAILED CIRCUIT ANALYSIS

(Refer to Overall Schematic at Rear of Manual.)

4-10 SERIES REGULATOR

4-11 The series regulator consists of transistor stage Q11. The regulator serves as a series control element by altering its conduction so that the output voltage and the current limit is never exceeded. The conduction of Q11 is controlled by the feedback voltage obtained from driver Q10.

4-12 CONSTANT VOLTAGE INPUT CIRCUIT

4-13 This circuit consists of the programming resistors, coarse voltage adjustment R20, fine voltage adjustment R11, and differential amplifiers Q1, Q2-Q3, and Q7-Q8. Q1 consists of two transistors having closely matched characteristics in a single transistor package. This package insures that both transistors will operate at essentially the same temperature, minimizing drift due to thermal differentials. Q1, Q2, and Q3 are enclosed in a constant-temperature oven to further minimize the effects of changing ambient temperature.

4-14 The constant voltage input circuit continuously compares a fixed reference voltage with a portion of the output voltage and, if a difference exists, produces an error voltage whose amplitude and phase is proportional to the difference. The error output is fed back to the series regulator, through the error and driver amplifiers. The error voltage changes the conduction of the series regulator which, in turn, alters the output voltage so that the difference between the two input voltages applied to the differential amplifier is reduced to zero. The above action maintains the output voltage constant.

4-15 The base of Q1A is connected to the junction of the programming resistors and the current pullout resistor (R18 or R19) through a current limiting resistor, R1. Note that when internal programming is used, R19 is the current pullout resistor, having similar temperature characteristics as the front panel voltage control. In remote programming, R18 is the current pullout, having as low a temperature coefficient as possible. Diodes CR1 and CR2 limit voltage excursions on the base of Q1A. R1 limits the current through the programming resistors under the condition of rapid voltage turndown. Capacitor C4 shunts the programming resistor to increase the high frequency gain of the amplifier. The programming current is determined primarily by the reference voltage and the pullout resistor, R18 or R19. R17 in series with the pullout resistor serves as a trimming adjustment of the programming current. A variable current injected at the junction of the

programming and pullout resistors through R15 allows fine trimming of the programming current.

4-16 The base of Q1B is connected to ground through R2. Variable currents can be injected at this point through R13 which serves to compensate for fixed voltage offsets in Q1, and through R11 which is the fine voltage adjustment.

4-17 Negative feedback is coupled from the output of differential amplifier Q7-Q8 to the input of Q1 by network R30 and C6. This feedback provides high frequency roll off in the loop gain to stabilize the feedback loop.

4-18 DRIVER AND ERROR AMPLIFIER

4-19 The driver and error amplifier circuit raises the level of the error signal from the constant voltage input circuit a sufficient amount to drive the series regulator. Common emitter amplifier Q10 also receives a current limiting input when CR8 becomes forward biased.

4-20 CURRENT LIMIT CIRCUIT

4-21 The output current flows through R23 producing a voltage drop of one volt for 500 ma output current. Current limit control, R25 is attached to R23 and goes positive as the output current increases. When this positive voltage is great enough to overcome the negative voltage resulting from the current limit control setting, Q5 is turned on. This action causes test point 21 to fall to about zero volts, forward biasing CR8 and carrying the base of Q10 sufficiently negative to turn it off, thus turning off the series regulator. R27 and CR4 provide a -0.7V bias for the emitter of Q5.

4-22 OVEN CONTROL CIRCUIT

4-23 The oven temperature is sensed by thermistor R57. If the temperature is too low, the resistance of R57 will be high enough to bias the emitter of unijunction transistor Q16 sufficiently positive for it to act as a free-running pulse generator. These pulses are coupled through C23 and R62 to the gate of the Silicon-Controlled Rectifier CR31. The first pulse in any half-cycle of line voltage will cause CR31 to conduct and remain conducting to the end of that half-cycle. When CR31 is conducting, current flows through the oven heater winding raising the temperature. When the temperature is high enough, R57 will have decreased sufficiently to lower the emitter bias of Q16, stopping its output pulses and leaving CR31 off.

4-24 REFERENCE CIRCUIT

4-25 The reference circuit is a feedback power supply similar to the main supply. It provides stable reference voltages which are used throughout the unit. The reference voltages are all derived from raw dc obtained from the full wave rectifier (CR24 and CR25) and filter capacitor C16. The +6.2 and -9.4 voltages, which are used in the constant voltage input circuit for comparison purposes, are developed across temperature compensated Zener diodes VR1 and VR2. Resistor R49 limits the current through the Zener diodes to establish an optimum bias level.

4-26 The reference circuit is a closed loop feedback regulator which acts to maintain the voltage at point 16 at 12.4 volts regardless of line voltage variation. Any difference between the zener reference diode VR1 and one-half of the 12.4 volt bus as sampled by R47 and R48 is amplified by Q14 and Q15 connected as a differential amplifier. The error is further amplified by Q13 and is applied to the base of series regulator Q12 which controls the output voltage of the reference circuit.

4-27 Zener diode VR2 is added in series with the reference outputs to provide a -9.4 volt bias output. The main reference voltage is the -6.2 volt zener VR1. The 12.4 volt output is used as a stable bias source. Diode CR19 provides initial start-up bias for the reference circuit when the power supply is first turned on.

4-28 METER CIRCUIT

4-29 The meter circuit provides continuous indications of output voltage or current on a single multiple range meter. The meter can be used either as a voltmeter or an ammeter depending upon the position of METER switch S2 on the front panel of the supply. This switch also selects one of two meter ranges on each scale. The meter circuit consists of METER switch S2, various multiplying resistors and the meter movement.

4-30 With METER switch S2 set to either voltage position 1 or 2 (Figure 4-3A), the meter is connected in series with R21, R69, R66, R22, and R42 across the output of the supply. Resistor R66 calibrates the meter for full scale deflection to compensate for slight resistance variations inherent in different meter movements. Thermistor R22 compensates for the change in meter resistance as a function of temperature, and R42 linearizes the resistance slope of R22 to match the meter resistance slope.

4-31 Voltage Adjust potentiometer R67 shunts a small amount of meter current and is adjusted for proper full scale meter deflection in the voltage

S2 SWITCH POSITIONS							
MODEL	6101A	6102A	6106A	6111A	6112A	6113A	6116A
1	2.5V	5V	12V	2.5V	5V	2.5V	12V
2	25V	50V	120V	25V	50V	25V	120V
3	1.2A	.5A	.25A	1.2A	.6A	2.5A	.25A
4	.12A	.06A	.025A	.12A	.02A	.25A	.025A

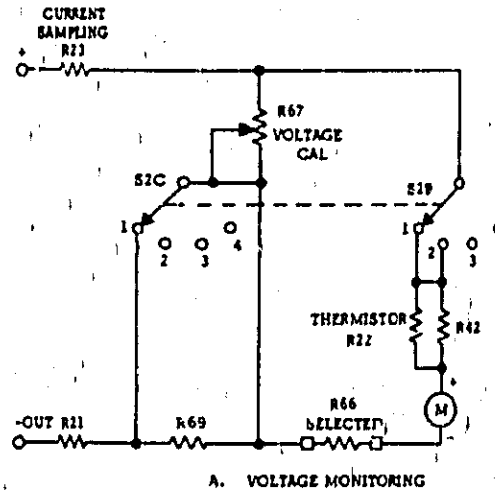

A. VOLTAGE MONITORING

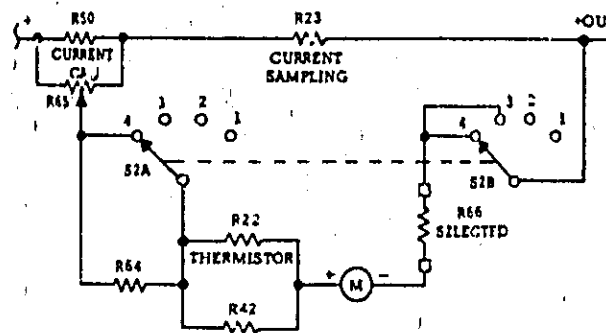

B. CURRENT MONITORING

Figure 4-3. Meter Circuit, Simplified Schematic

ranges. METER switch S2C shunts R69 in position 1 (the low voltage range). Thus, in the low voltage range the meter receives 10 times the amount of current that it receives in the high voltage range, for the same power supply output.

4-32 With METER switch S2 set to either current position 3 or 4 (Figure 4-3B), the meter is connected across the current sampling resistor R23. Current calibrate potentiometer R63 is adjusted for proper full scale meter deflection in the current ranges. METER switch S2A shunts R64 in position 4 (the low current range).

4-33 The meter is manufactured with a foolproof movement, that is, it can withstand a current overload of more than 10 times the maximum range without injury.

SECTION V MAINTENANCE

5-1 INTRODUCTION

5-2 Upon receipt of the power supply, the performance check (Paragraph 5-10) should be made. This check is suitable for incoming inspection. If a fault is detected in the power supply while making the performance check or during normal operation, proceed to the troubleshooting procedures (Paragraph 5-27). After troubleshooting and repair (Paragraph 5-37), perform any necessary adjustments and calibrations (Paragraph 5-39). Before returning the power supply to normal operation, repeat the performance check to ensure that the fault has been properly corrected and that no other faults exist. Before doing any maintenance checks, turn-on power supply, allow a half-hour warm-up, and read the general information regarding measurement techniques (Paragraph 5-3).

5-3 GENERAL MEASUREMENT TECHNIQUES

5-4 The measuring device must be connected across the sensing leads of the supply or as close to the output terminals as possible when measuring the output impedance, transient response, regulation, or ripple of the power supply in order to achieve valid measurements. A measurement made across the load includes the impedance of the leads to the load and such lead lengths can easily have an impedance several orders of magnitude greater than the supply impedance, thus invalidating the measurement.

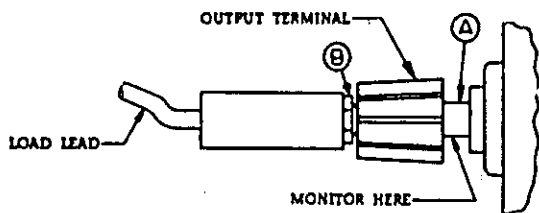

Figure 5-1. Front Panel Terminal Connections

5-5 The monitoring device should be connected to the rear +S and -S terminals (see Figure 3-2) or as shown in Figure 5-1. The performance characteristics should never be measured on the front terminals if the load is connected across the rear terminals. Note that when measurements are made at the front terminals, the monitoring leads are connected at A, not B, as shown in Figure 5-1. Failure to connect the measuring device at A will result in a measurement that includes the resistance of the leads between the output terminals and the point of connection.

5-6 For output current measurements, the current sampling resistor should be a four-terminal resistor. The four terminals are connected as shown in Figure 5-2. In addition, the resistor should be of the low noise, low temperature coefficient (less than 30 ppm/°C) type and should be used at no more than 5% of its rated power so that its temperature rise will be minimized.

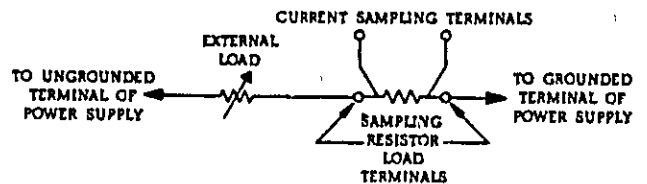

Figure 5-2. Output Current Measurement Technique

5-7 When using an oscilloscope, ground one terminal of the power supply and then ground the case of the oscilloscope to this same point. Make certain that the case is not also grounded by some other means (power line). Connect both oscilloscope input leads to the power supply ground terminal and check that the oscilloscope is not exhibiting a ripple or transient due to ground loops, pick-up, or other means.

5-8 TEST EQUIPMENT REQUIRED

5-9 Table 5-1 lists the test equipment required to perform the various procedures described in this Section.

Table 5-1. Test Equipment Required

Type	Required Characteristics	Use	Recommended Model
Differential Voltmeter	Sensitivity: 1 mv full scale (min.). Input impedance: 10 megohms (min.).	Measure DC voltages; calibration procedures	Ⓢ 3420 (See Note)
Variable Voltage Transformer	Range: 90-130 volts. Equipped with voltmeter accurate within 1 volt.	Vary AC input	-----
AC Voltmeter	Accuracy: 2%. Sensitivity: 1 mv full scale deflection (min.).	Measure AC voltages and ripple	Ⓢ 403 B
Oscilloscope	Sensitivity: 100 μ v/cm. Differential input.	Display transient response waveforms	Ⓢ 140 A plus 1400A plug in.
Oscillator	Range: 5 cps to 600 Kc. Accuracy: 2%	Impedance checks	Ⓢ 200 CD
DC Voltmeter	Accuracy: 1%. Input resistance: 20,000 ohms/volt (min.).	Measure DC voltages	Ⓢ 412 A
Repetitive Load Switch	Rate: 60 — 400 Hz, 2 μ sec rise and fall time.	Measure transient response	See Figure 5-7
Resistive Loads	Values: See Paragraph 5-14 and Figure 5-4. \pm 5%, 75 watts.	Power supply load resistors	-----
Current Sampling Resistor	Value: See Figure 5-4. 1%, 40 watts, 20ppm, 4-Terminal.	Measure current; calibrate meter	-----
Resistor	1K Ω \pm 1%, 2 watt non-inductive	Measure impedance	-----
Resistor	100 ohms, \pm 5%, 10 watt.	Measure impedance	-----
Resistor	Value: See Paragraph 5-49. \pm 0.1%, 1/2 watt.	Calibrate programming current	-----
Capacitor	500 μ f, 50wvdc	Measure impedance.	-----
Decade Resistance Box	Range: 0-500K. Accuracy: 0.1% plus 1 ohm Make-before-break contacts.	Measure programming coefficients.	-----

5-10 PERFORMANCE TEST

5-11 The following test can be used as an incoming inspection check and appropriate portions or the test can be repeated either to check the operation of the instrument after repairs or for periodic maintenance tests. The test is performed using a 115-VAC 60 cps., single phase input power source. If the correct result is not obtained for a particular check, do not adjust any controls; proceed to troubleshooting (Paragraph 5-27).

NOTE

A satisfactory substitute for a differential voltmeter is to arrange a reference voltage source and null detector as shown in Figure 5-3. The reference voltage source is adjusted so that the voltage difference between the supply being measured and the reference voltage will have the required resolution for the measurement being made. The voltage difference will be a function of the null detector that is used. Examples of satisfactory null detectors are: ① 419 A null detector, a DC coupled oscilloscope utilizing differential input, or a 50 mv meter movement with a 100 division scale. For the latter, a 2 mv change in voltage will result in a meter deflection of four divisions.

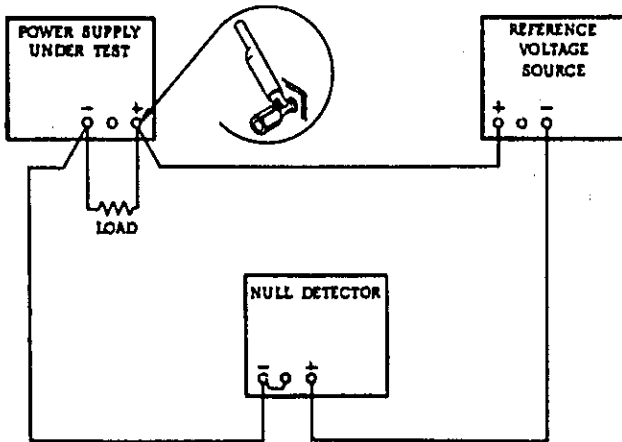

Figure 5-3. Differential Voltmeter Substitute Test Setup

CAUTION

Care must be exercised when using an electronic null detector in which one input terminal is grounded to avoid ground loops and circulating currents.

5-12 RATED OUTPUT AND METER ACCURACY

5-13 Voltage, Proceed as follows:

a. Connect load resistor across rear output terminals of supply for full load output. Resistor value to be as follows:

<u>Model No.</u>	6101A	6102A	6106A	6111A	6112A
<u>Resistance</u>	20 Ω	80 Ω	500 Ω	20 Ω	80 Ω
<u>Model No.</u>	6113A	6116A			
<u>Resistance</u>	5 Ω	500 Ω			

b. Connect differential voltmeter across +S and -S terminals of supply observing correct polarity.

c. Set METER switch to highest voltage range and turn on supply.

d. Adjust VOLTAGE controls until front panel meter indicates exactly the maximum rated output voltage.

e. Differential voltmeter should indicate maximum rated output voltage within $\pm 2\%$.

5-14 Current, Proceed as follows:

a. Connect test setup shown in Figure 5-4.

b. Turn CURRENT controls fully clockwise.

c. Set METER switch to highest current range and turn on supply.

d. Adjust VOLTAGE controls until front panel meter indicates exactly the maximum rated output current.

e. Differential voltmeter should read 1.0 ± 0.02 Vdc.

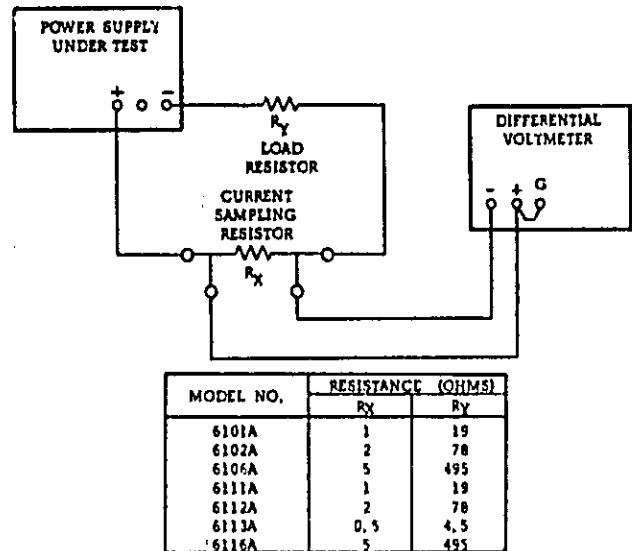

Figure 5-4. Output Current, Test Setup

5-15 LOAD REGULATION (Frnt Terminals)

5-16 To check constant voltage load regulation, proceed as follows:

- a. Connect test setup as shown in Figure 5-5.
- b. Turn CURRENT controls fully clockwise.
- c. Set METER switch to highest current range and turn on supply.
- d. Adjust VOLTAGE controls until front panel meter indicates exactly the maximum rated output voltage.
- e. Read and record voltage indicated on differential voltmeter.
- f. Disconnect load resistors.
- g. Reading on differential voltmeter should not vary from reading recorded in step e by more than the following:

Model No.	6101A	6102A	6106A	6111A
Variation (mvdc)	0.8	0.75	1.2	0.8
Model No.	6112A	6113A	6116A	
Variation (mvdc)	0.75	1.2	1.2	

5-17 LINE REGULATION (Front Terminals)

5-18 To check the line regulation, proceed as follows:

- a. Connect variable auto transformer between input power source and power supply power input.
- b. Turn CURRENT controls fully clockwise.
- c. Connect test setup shown in Figure 5-5.

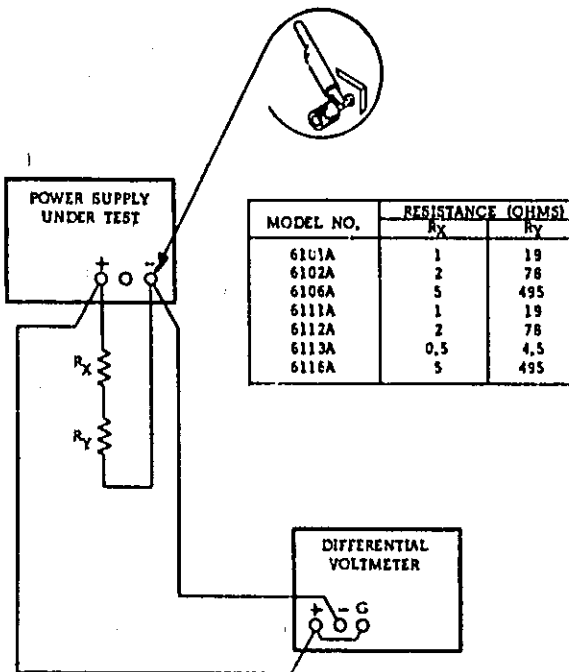

Figure 5-5. Load Regulation, Test Setup

d. Adjust variable auto transformer for 105 VAC input.

e. Set METER switch to highest voltage range and turn on supply.

f. Adjust VOLTAGE controls until front panel meter indicates exactly the maximum rated output voltage.

g. Read and record voltage indicated on differential voltmeter.

h. Adjust variable auto transformer for 125 VAC input.

i. Reading on differential voltmeter should not vary from reading recorded in step g by more than the following:

Model No.	6101A	6102A	6106A	6111A
Variation (mvdc)	0.2	0.4	1	0.2
Model No.	6112A	6113A	6116A	
Variation (mvdc)	0.4	0.1	1	

5-19 RIPPLE AND NOISE

5-20 To check the ripple and noise, proceed as follows:

a. Retain test setup used for previous line regulation test except connect oscilloscope across output terminals as shown in Figure 5-6.

b. Adjust variable auto transformer for 125 VAC input.

c. Set METER switch to highest current range.

d. Turn CURRENT controls fully clockwise and adjust VOLTAGE controls until front panel meter indicates exactly the maximum rated output voltage.

e. Oscilloscope should indicate 100µV peak-to-peak or less.

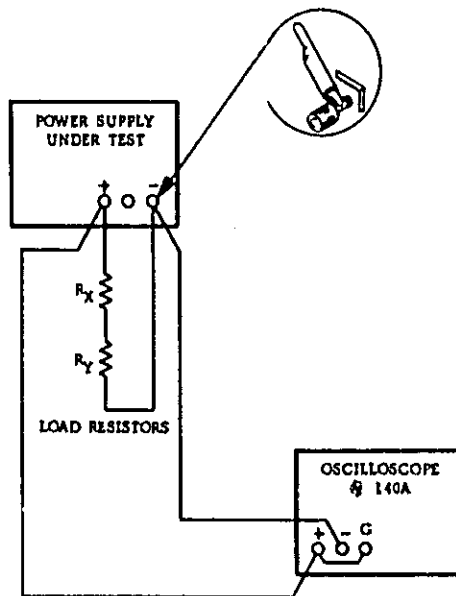
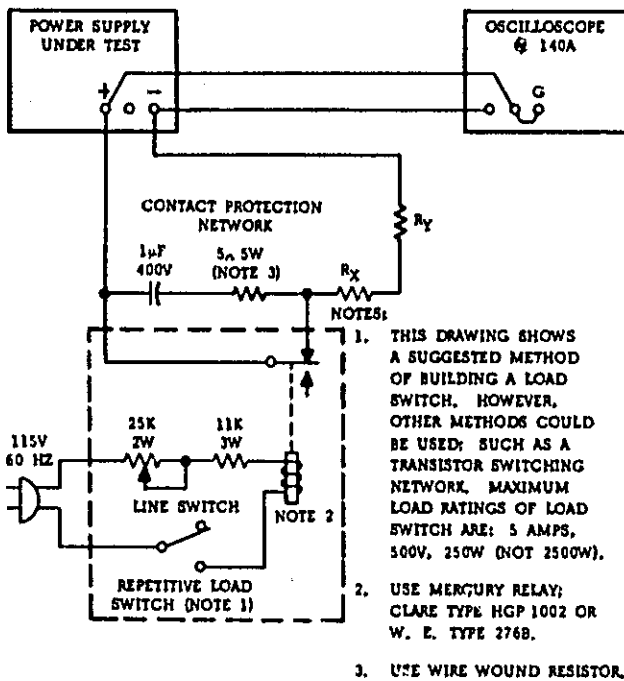

Figure 5-6. Ripple and Noise, Test Setup

5-21 TRANSIENT RECOVERY TIME

5-22 To check the transient recovery time proceed as follows:

- Connect test setup shown in Figure 5-7.
- Turn CURRENT controls fully clockwise.
- Set METER switch to highest current range and turn on supply.
- Adjust VOLTAGE controls until front panel meter indicates exactly the maximum rated output voltage.
- Close line switch on repetitive load switch setup.
- Adjust 25K potentiometer until a stable display is obtained on oscilloscope. Waveform should be within the tolerances shown in Figure 5-8 (output should return to within 10 mv of original value in less than 50 microseconds).



MODEL NO.	RESISTANCE (OHMS)	
	R _x	R _y
6101A	1	19
6102A	2	78
6106A	5	495
6111A	1	19
6112A	2	78
6113A	5	4.5
6116A	5	495

Figure 5-7. Transient Recovery Time, Test Setup

NOTE

If the unloading waveform is unobtainable, use a smaller value capacitor in the contact protection network illustrated in Figure 5-7.

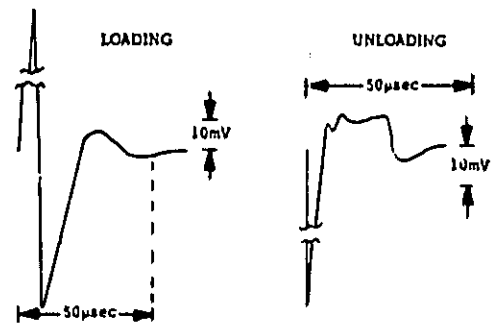

Figure 5-8. Transient Recovery Time, Waveforms

5-23 OUTPUT IMPEDANCE

5-24 To check the output impedance, proceed as follows:

- Connect test setup as shown in Figure 5-9.

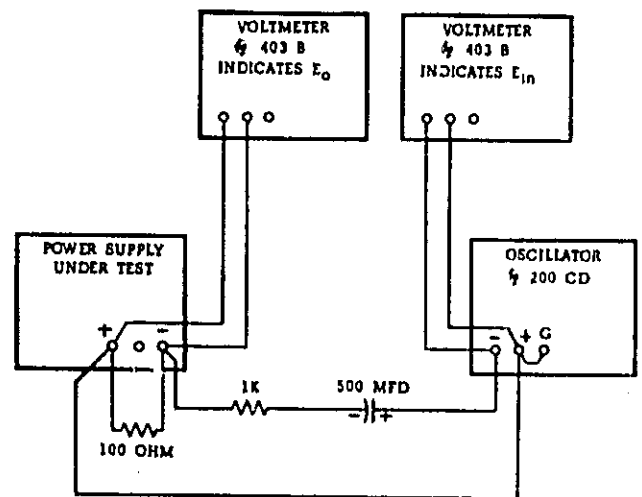

Figure 5-9. Output Impedance, Test Setup

- Set METER switch to highest voltage range, turn CURRENT controls fully clockwise, and turn on supply.
- Adjust VOLTAGE controls until front panel meter reads 20 volts (10 volts for Model 6113A supplies).
- Set AMPLITUDE control on Oscillator to 10 volts (E_{in}), and FREQUENCY control to 10 cps.
- Record voltage across output terminals of the power supply (E_o) as indicated on AC voltmeter.
- Calculate the output impedance by the following formula:

$$Z_{out} = \frac{E_o R}{E_{in} - E_o}$$

E_o = rms voltage across power supply output terminals.

$R = 1000$

$E_{in} = 10$ volts

g. The output impedance (Z_{out}) should be less than 0.002 ohm.

h. Using formula of step f, calculate output impedance at frequencies of 100cps, 1Kc, and 500Kc. Values should be less than 0.02 ohm, 0.5 ohm, and 3 ohms, respectively.

5-25 CURRENT LIMIT

5-26 To check the current limit circuit, proceed as follows:

- a. Set the METER switch to the highest voltage range.
- b. Turn the VOLTAGE controls fully clockwise.
- c. Turn the CURRENT control fully counter-clockwise.
- d. The voltage should reduce to zero.
- e. Connect a short circuit across the output terminals.
- f. Set the METER switch to the highest current range.
- g. Turn the CURRENT control fully clockwise.
- h. The current should increase to, but not exceed the following:

Model	6101A	6102A	6106A	6111A
Current Limit (A)	1.05	0.52	0.21	1.05
Model	6112A	6113A	6116A	
Current Limit (A)	0.52	2.1	0.21	

5-27 TROUBLESHOOTING

5-28 Components within Hewlett-Packard power supplies are conservatively operated to provide maximum reliability. In spite of this, parts within a supply may fail. Usually the instrument must be immediately repaired with a minimum of "down time" and a systematic approach as outlined in succeeding paragraphs can greatly simplify and speed up the repair.

5-29 TROUBLE ANALYSIS

5-30 General. Before attempting to trouble shoot this instrument, ensure that the fault is with the instrument and not with an associated circuit.

The performance test (Paragraph 5-10) enables this to be determined without having to remove the instrument from the cabinet.

5-31 Once it is determined that the power supply is at fault, check for obvious troubles such as open fuse, a defective power cable, or an input power failure. Next, remove the top and bottom covers (each held by four retaining screws) and inspect for open connections, charred components, etc. If the trouble source cannot be detected by visual inspection, follow the detailed procedure outlined in succeeding paragraphs. Once the defective component has been located (by means of visual inspection or trouble analysis) correct it and re-conduct the performance test. If a component is replaced, refer to the repair and replacement, and adjustment and calibration paragraphs in this section.

5-32 A good understanding of the principles of operation is a helpful aid in troubleshooting, and it is recommended that the reader review Section IV of the manual before attempting to troubleshoot the unit in detail. Once the principles of operation are understood, logical application of this knowledge used in conjunction with the normal voltage readings shown on the schematic and the additional procedure given in the following paragraphs should suffice to isolate a fault to a component or small group of components. The normal voltages shown on the schematic are positioned adjacent to the applicable test points (identified by encircled numbers on the schematic and printed wiring boards). Additional test procedures that will aid in isolating troubles are as follows:

- a. Reference circuit check (Paragraph 5-34). This circuit provides critical operating voltages for the supply and faults in the circuit could affect the overall operation in many ways.
- b. Feedback loop checks (Paragraph 5-35).
- c. Procedures for isolating common troubles (Paragraph 5-36).

5-33 The test points referred to throughout the following procedures are identified on the schematic diagram by encircled numbers.

Table 5-2. Reference Circuit Troubleshooting

Step	Meter Common	Meter Positive	Normal Indication	If Indication Abnormal, Take This Action
1	+S	30	6.2 ± 0.3vdc	Check 12.4 volt bias or VR1
2	34	+S	9.4 ± 0.4vdc	Check 12.4 volt bias or VR2
3	+S	16	12.4 ± 1.0vdc	Check Q12-Q15, CR24, CR25, C16, T1

5-34 Reference Circuit.

a. Make an ohmmeter check to be certain that neither the positive nor negative output terminal is grounded.

b. Turn front-panel VOLTAGE and CURRENT controls fully clockwise (maximum).

c. Turn-on power supply (no load connected).

d. Proceed as instructed in Table 5-2.

5-35 Feedback Circuit. Generally, malfunction of the feedback circuit is indicated by high or low output voltages. If one of these situations occurs, disconnect the load and proceed as instructed in Table 5-3 or Table 5-4.

Table 5-3. High Output Voltage Troubleshooting

Step	Measure (-) (+)	Response	Probable Cause
1	Voltage between +S and A5.	a. +0.6V b. 0V or negative	a. Open strap between A8 and -S. R20 open. b. Proceed to Step 2.
2	Voltage between 13 and 14.	a. More negative than -0.1V. b. Within ±0.1V of 0V. c. More positive than +0.1V.	a. Q1A shorted, R1, R2 open. b. C6, C3 shorted. c. Proceed to Step 3.
3	Voltage between +S and 25.	a. More negative than +0.5V. b. More positive than +0.5V.	a. Q7, C8, CR9, R32 shorted. Q8, R23, R31, R33 open. b. Proceed to Step 4.
4	Voltage between +S and 27.	a. 0V to +0.2V. b. More positive than 0.2V.	a. Q10 or Q11 shorted. b. Q9 open, R35 shorted.

Table 5-4. Low Output Voltage Troubleshooting

Step	Measure (-) (+)	Response	Probable Cause
1	Disable Q5 by disconnecting CR8.	a. Normal output voltage. b. Low output voltage.	a. Current limit circuit faulty, check CR8, Q5, and R26 for short. b. Reconnect CR8 and proceed to Step 2.
2	Voltage between +S and A5.	a. More negative than +0.1V. b. +0.1V to +0.8V.	a. C4 shorted, R17, R18 open. b. Proceed to Step 3.
3	Voltage between 13 and 14	a. More positive than +0.1V. b. More negative than -0.1V.	a. Q1A open. R1, R2 open. b. Proceed to Step 4.

Table 5-4. Low Output Voltage Troubleshooting (Continued)

4	Voltage between +S and 25.	a. More positive than +0.6V. b. More negative than +0.5V.	a. Q8 shorted, Q7 open, C10 shorted. * b. Proceed to Step 5.
5	Voltage between +S and 27.	a. More positive than 1V. b. More negative than 0V.	a. Q10, Q11 open. R38 shorted. b. Q9, CR10, CR11, CR12, C9 shorted, CR13, CR14, CR15 open, R35 open.

*Check Q9 and CR9 for damage

Table 5-5. Common Troubles

Symptom	Checks and Probable Causes
High ripple	a. Check operating setup for ground loops. b. If output floating, connect 1 μ f capacitor between output and ground. c. Ensure that supply is not crossing over to current limit mode under loaded conditions. Check for low voltage across C19.
Poor line regulation	a. Check reference circuit (Paragraph 5-34).
Poor load regulation (Constant Voltage)	a. Measurement technique. (Paragraph 5-15.) b. Check reference circuit (Paragraph 5-34). c. Ensure that supply is not going into current limit. Check current limit circuit.
Oscillates a. Constant Voltage Operation b. Current Limit Operation	a. C6, R30, C3, R9, C7, R34, C8, or C9 open b. C5, R29, or C9 open
Poor Stability (Constant Voltage)	a. Check ± 6.2 Vdc reference voltages (Paragraph 5-34). b. Noisy programming resistor R20. c. CR1, CR2 leaky. d. Check R10, R11, VR1 for noise or drift. e. Stage Q1 defective.

5-36 Common Troubles. Table 5-5 lists the symptoms, checks, and probable causes for common troubles.

5-37 REPAIR AND REPLACEMENT

5-38 Before servicing a printed wiring board, refer to Figure 5-10. Section VI of this manual

contains a list of replaceable parts. Before replacing a semiconductor device, refer to Table 5-6 which lists the special characteristics of selected semiconductors. If the device to be replaced is not listed in Table 5-6, the standard manufacturers part number listed in Section VI is applicable. After replacing a semiconductor device, refer to Table 5-7 for checks and adjustments that may be necessary.

Excessive heat or pressure can lift the copper strip from the board. Avoid damage by using a low power soldering iron (50 watts maximum) and following these instructions. Copper that lifts off the board should be cemented in place with a quick drying acetate base cement having good electrical insulating properties.

A break in the copper should be repaired by soldering a short length of tinned copper wire across the break.

Use only high quality rosin core solder when repairing etched circuit boards. NEVER USE PASTE FLUX. After soldering, clean off any excess flux and coat the repaired area with a high quality electrical varnish or lacquer.

When replacing components with multiple mounting pins such as tube sockets, electrolytic capacitors, and potentiometers, it will be necessary to lift each pin slightly, working around the components several times until it is free.

WARNING: If the specific instructions outlined in the steps below regarding etched circuit boards without eyelets are not followed, extensive damage to the etched circuit board will result.

1. Apply heat sparingly to lead of component to be replaced. If lead of component passes through an eyelet in the circuit board, apply heat on component side of board. If lead of component does not pass through an eyelet, apply heat to conductor side of board.

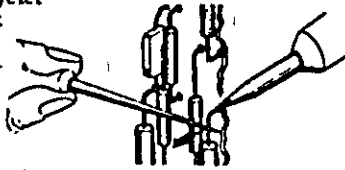

2. Reheat solder in vacant eyelet and quickly insert a small awl to clean inside of hole.

If hole does not have an eyelet, insert awl or a #57 drill from conductor side of board.

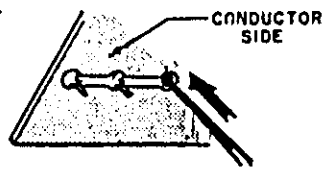

3. Bend clean tinned lead on new part and carefully insert through eyelets or holes in board.

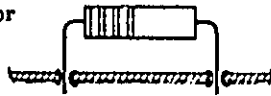

4. Hold part against board (avoid overheating) and solder leads. Apply heat to component leads on correct side of board as explained in step 1.

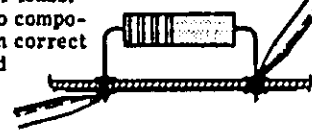

In the event that either the circuit board has been damaged or the conventional method is impractical, use method shown below. This is especially applicable for circuit boards without eyelets.

1. Clip lead as shown below.

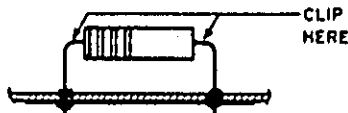

2. Bend protruding leads upward. Bend lead of new component around protruding lead. Apply solder using a pair of long nose pliers as a heat sink.

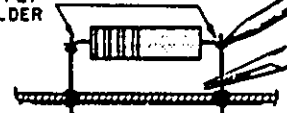

This procedure is used in the field only as an alternate means of repair. It is not used within the factory.

Figure 5-10. Servicing Printed Wiring Boards

Table 5-6. Selected Semiconductor Characteristics

Reference Designator	Characteristics	Stock No.	Suggested Replacement
Q1	Diff. Amp. NPN	1854-0221	2N4045
Q2, Q3, Q9, Q10, Q13-Q15	SS NPN Silicon	1854-0027	2N2714
CR1, CR2, CR4, CR8, CR9, CR16, CR31	Diode, Silicon	1901-0033	1N485B Sylvania
CR10, CR13 CR20	Diode, Sil, 2.4V @ 100 mA	1901-0460	1N4830 G. E.
CR19, CR23	Rect, Sil, Stabistor 200 mA, 10prv	1901-0461	1N4828 G. E.
CR24-CR29, CR30B, CR32-CR34	Rect, Silicon 500 mA, 200prv	1901-0026	1N3253 R. C. A.

Table 5-7. Checks and Adjustments After Replacement of Semiconductor Devices

Reference	Function	Check	Adjust
Q1, Q2, Q3, Q7, Q8, Q9	Voltage error amplifier	Voltage load regulation Remote programming	R14
Q10, Q11	Series Regulator	Voltage load regulation	
Q5	Current Limit Amplifier	Current limit operation	
Q12, 13, 14, 15	Reference Circuit Amplifier	+6.2V line regulation	
Q16	Oven Control Pulse Generator	Oven temperature setting	R56
CR1, 2	Protection Diode	Voltage-load regulation	
CR4, 10, 13	Forward Bias Regulators	Voltage across each diode 0.6 to 0.85 volts	
CR8	Current Limit Coupling Diode	Current limit operation	
CR9	Overshoot suppressor diode	Turn-on overshoot	
CR16	Overshoot suppressor diode	Turn-on overshoot	
CR19	Reference Circuit Start-up diode	Reference circuit operation	
CR24, 25	Rectifier	Voltage on C16	
CR26, 27, 28	Rectifier	Voltage on C17	

Table 5-7. Checks and Adjustments After Replacement of Semiconductor Devices (Continued)

CR29, 30, 33, 34	Rectifier	Voltage on C19	
CR31	Oven SCR	Oven Functioning	
CR32	Protection diode		
VR1	+6.2 Voltage Reference	Remote Programming Coefficient, zero crossing	R17, R16 R14
VR2	-9.4 Voltage Reference	Remote Prog. Coefficient zero crossing	R16 R14
MI, R64, or R66		Current meter cal. Voltage meter cal.	R65 R67

5-39 ADJUSTMENT AND CALIBRATION

5-40 Adjustment and calibration may be required after performance testing, troubleshooting, or repair and replacement. Perform only those ad-

justments that affect the operation of the faulty circuit and no others. Table 5-8 summarizes the adjustments and calibrations contained in the following paragraphs.

Table 5-8. Calibration Adjustment Summary

Adjustment or Calibration	Paragraph	Control Device
Meter Zero	5-41	Pointer
Voltmeter Tracking	5-43	R67
Ammeter Tracking	5-45	R65
Zero Volt Programming Accuracy	5-47	R6 or R8
Programming Current Level	5-49	R13

5-41 METER ZERO

5-42 Proceed as follows to zero meter:

- a. Turn off instrument (after it has reached normal operating temperature) and allow 30 seconds for all capacitors to discharge.
- b. Insert sharp pointed object (pen point or awl) into the small indentation near top of round black plastic disc located directly below meter face.
- c. Rotate plastic disc clockwise (cw) until meter reads zero, then rotate ccw slightly in order to free adjustment screw from meter suspension. If pointer moves, repeat steps b and c.

5-43 VOLTMETER TRACKING

5-44 To calibrate voltmeter tracking, proceed as follows:

- a. Connect differential voltmeter across supply, observing correct polarity.
- b. Set METER switch to highest voltage range and turn on supply. Adjust VOLTAGE control until differential voltmeter reads exactly the maximum rated output voltage.
- c. Adjust R67 until front panel meter also indicates maximum rated output voltage.

5-45 AMMETER TRACKING

5-46 To calibrate ammeter tracking proceed as follows:

- a. Connect test setup shown on Figure 5-4.
- b. Turn VOLTAGE control fully clockwise and set METER switch to highest current range.
- c. Turn on supply and adjust CURRENT controls until differential voltmeter reads 1.0 Vdc.
- d. Adjust R65 until front panel meter indicates exactly the maximum rated output current.

5-47 CONSTANT VOLTAGE PROGRAMMING CURRENT

5-48 Zero Volt Programming Accuracy. To calibrate the zero volt programming accuracy, proceed as follows:

- a. Connect differential voltmeter between +S and -S terminals.
- b. Short voltage controls by connecting jumper between terminals A5 and -S.
- c. Rotate CURRENT control fully clockwise and turn on supply.
- d. Adjust zero crossing potentiometer R14 until the meter indicates zero volts.

5-49 Programming Current Level. To calibrate the constant voltage programming current level, proceed as follows:

a. Connect the supply under test for remote resistance programming as illustrated in Figure 3-3.

b. Connect a 0.1%, 2-watt programming resistor between terminals A4 and -S on rear barrier strip. Resistor value to be as follows:

Model	6101A	6102A	6106A	6111A
Resistance (ohms)	20K	40K	100K	20K
Model	6112A	6113A	6116A	
Resistance (ohms)	40K	10K	100K	

c. Connect a differential voltmeter between -S and +S and turn on the supply.

d. Adjust potentiometer R16 until differential voltmeter indicates the maximum rated output voltage of the supply. If the range of R16 is not sufficient to adjust the output voltage within tolerance proceed to step e.

e. Set potentiometer R16 to the center of its range.

f. Replace R17 with a resistance decade initially set for 300 ohms.

g. Adjust the resistance decade until the differential voltmeter indicates the maximum rated output voltage of the supply.

h. Replace the decade resistance with a resistor whose value is as close to the resistance decade as possible.

i. Readjust R16 until the differential voltmeter indicates the maximum rated output voltage of the supply.

SECTION VI REPLACEABLE PARTS

6-1 INTRODUCTION

6-2 This section contains information for ordering replacement parts. Table 6-4 lists parts in alphanumeric order by reference designators and provides the following information:

- a. Reference Designators. Refer to Table 6-1.
- b. Description. Refer to Table 6-2 for abbreviations.
- c. Total Quantity (TQ). Given only the first time the part number is listed except in Instruments containing many sub-modular assemblies, in which case the TQ appears the first time the part number is listed in each assembly.
- d. Manufacturer's Part Number or Type.
- e. Manufacturer's Federal Supply Code Number. Refer to Table 6-3 for manufacturer's name and address.
- f. Hewlett-Packard Part Number.
- g. Recommended Spare Parts Quantity (RS) for complete maintenance of one instrument during one year of isolated service.
- h. Parts not identified by a reference designator are listed at the end of Table 6-4 under Mechanical and/or Miscellaneous. The former consists of parts belonging to and grouped by individual assemblies; the latter consists of all parts not immediately associated with an assembly.

6-3 ORDERING INFORMATION

6-4 To order a replacement part, address order or inquiry to your local Hewlett-Packard sales office (see lists at rear of this manual for addresses). Specify the following information for each part: Model, complete serial number, and any Option or special modification (S) numbers of the instrument; Hewlett-Packard part number; circuit reference designator; and description. To order a part not listed in Table 6-4, give a complete description of the part, its function, and its location.

Table 6-1. Reference Designators

A = assembly	E = miscellaneous electronic part
B = blower (fan)	F = fuse
C = capacitor	J = jack, jumper
CB = circuit breaker	K = relay
CR = diode	L = inductor
DS = device, signaling (lamp)	M = meter

Table 6-1. Reference Designators (Continued)

P = plug	V = vacuum tube, neon bulb, photocell, etc.
Q = transistor	VR = zener diode
R = resistor	X = socket
S = switch	Z = integrated circuit or network
T = transformer	
TB = terminal block	
TS = thermal switch	

Table 6-2. Description Abbreviations

A = ampere	mfr = manufacturer
ac = alternating current	mod. = modular or modified
assy. = assembly	mtg = mounting
bd = board	n = nano = 10^{-9}
bkt = bracket	NC = normally closed
°C = degree Centigrade	NO = normally open
cd = card	NP = nickel-plated
coef = coefficient	Ω = ohm
comp = composition	obd = order by description
CRT = cathode-ray tube	OD = outside diameter
CT = center-tapped	p = pico = 10^{-12}
dc = direct current	P.C. = printed circuit
DPDT = double pole, double throw	pot. = potentiometer
DPST = double pole, single throw	p-p = peak-to-peak
elect = electrolytic	ppm = parts per million
encap = encapsulated	pvr = peak reverse voltage
F = farad	rect = rectifier
°F = degree Fahrenheit	rms = root mean square
fxd = fixed	Si = silicon
Ge = germanium	SPDT = single pole, double throw
H = Henry	SPST = single pole, single throw
Hz = Hertz	SS = small signal
IC = integrated circuit	T = slow-blow
ID = inside diameter	tan. = tantalum
incnd = incandescent	Ti = titanium
k = kilo = 10^3	V = volt
m = milli = 10^{-3}	var = variable
M = mega = 10^6	ww = wirewound
μ = micro = 10^{-6}	W = Watt
met. = metal	

Table 6-3. Code List of Manufacturers

CODE NO.	MANUFACTURER	ADDRESS
00629	EBY Sales Co., Inc.	Jamaica, N. Y.
00650	Aerovox Corp.	New Bedford, Mass.
00853	Sangamo Electric Co.	Pickens, S. C.
01121	S. Carolina Div.	Milwaukee, Wis.
01255	Allen Bradley Co.	Beverly Hills, Calif.
01281	Litton Industries, Inc.	Lawndale, Calif.
01295	TRW Semiconductors, Inc.	Dallas, Texas
01686	Texas Instruments, Inc.	Manchester, N. H.
01930	RCL Electronics, Inc.	Rockford, Ill.
02107	Amerock Corp.	Dover, Ohio
02114	Sparta Mfg. Co.	Saugerties, N. Y.
02606	Ferroxcube Corp.	Morton Grove, Ill.
02660	Fenwal Laboratories	Broadview, Ill.
02735	Amphenol Corp.	Somerville, N. J.
03508	Radio Corp. of America, Solid State and Receiving Tube Div.	Syracuse, N. Y.
03797	G. E. Semiconductor Products Dept.	Compton, Calif.
03877	Eldema Corp.	Wakefield, Mass.
03888	Transitron Electronic Corp.	Cedar Knolls, N. J.
04009	Pyrofilm Resistor Co. Inc.	Hartford, Conn.
04072	Arrow, Hart and Hegeman Electric Co.	Hampden City, Calif.
04213	ADC Electronics, Inc.	Mineola, N. Y.
04404	Caddell & Burns Mfg. Co. Inc.	Palo Alto Div.
04713	*Hewlett-Packard Co.	Palo Alto, Calif.
05277	Motorola Semiconductor Prod. Inc.	Phoenix, Arizona
05347	Westinghouse Electric Corp.	Youngwood, Pa.
05820	Semiconductor Dept.	Grand Junction, Colo.
06001	Ultronix, Inc.	Wakefield, Mass.
06004	Wakefield Engr. Inc.	Irmo, S. C.
06486	General Elect. Co. Electronic Capacitor & Battery Dept.	Bridgeport, Conn.
06540	Bassik Div. Stewart-Warner Corp.	Lynn, Mass.
06555	IRC Div. of TRW Inc.	New Rochelle, N. Y.
06666	Semiconductor Plant	Penacook, N. H.
06751	Amatom Electronic Hardware Co. Inc.	Indianapolis, Ind.
06776	Beede Electrical Instrument Co.	Phoenix, Arizona
06812	General Devices Co. Inc.	New Albany, Ind.
07137	Semcor Div. Components, Inc.	West Div.
	Robinson Nugent, Inc.	Van Nuys, Calif.
	Torrington Mfg. Co.,	Minneapolis, Minn.

CODE NO.	MANUFACTURER	ADDRESS
07138	Westinghouse Electric Corp.	Elmira, N. Y.
07263	Electronic Tube Div.	Fairchild Camera and Instrument Corp. Semiconductor Div.
07307		Mountain View, Calif.
07397	Birtcher Corp., The	Los Angeles, Calif.
07716	Sylvania Electric Prod. Inc.	Sylvania Electronic Systems Western Div.
07910	IRC Div. of TRW Inc.	Burlington Plant Burlington, Iowa
07933	Continental Device Corp.	Hawthorne, Calif.
08484	Raytheon Co. Components Div.	Mountain View, Calif.
08530	Semiconductor Operation	Union, N. J.
08717	Breeze Corporations, Inc.	Brooklyn, N. Y.
08730	Reliance Mica Corp.	Sun Valley, Calif.
08306	Sloan Company, The	Wyckoff, N. J.
08863	Vemaline Products Co. Inc.	Cleveland, Ohio
08919	General Elect. Co. Minia- ture Lamp Dept.	Norrisville, Pa.
09021	Nylomatic Corp.	Vernon, Calif.
09182	RCH Supply Co.	Bradford, Pa.
09213	Airco Speer Electronic Components	New Jersey Div. Berkeley Heights, N. J.
09214	*Hewlett-Packard Co.	Buffalo, N. Y.
09353	General Elect. Co. Semiconductor Prod. Dept.	Auburn, N. Y.
09922	General Elect. Co. Semiconductor Prod. Dept.	Newton, Mass.
11115	C & K Components Inc.	Norwalk, Conn.
11236	Burdy Corp.	Bloomfield, N. J.
11237	Wagner Electric Corp.	Berne, Ind.
11502	Tung-Sol Div.	So. Pasadena, Calif.
11711	CTS of Berne, Inc.	Boone, N. C.
12136	Chicago Telephone of Cal. Inc.	Newark, N. J.
12615	Philadelphia Handle Co. Inc.	Camden, N. J.
12617	U. S. Terminals, Inc.	Cincinnati, Ohio
12697	Hamlin Inc.	Lake Mills, Wisconsin
13103	Clarostat Mfg. Co. Inc.	Dover, N. H.
14493	Thermalloy Cp.	Dallas, Texas
14655	*Hewlett-Packard Co. Loveland Div.	Loveland, Colo.
14936	Cornell-Dubilier Electronics Div.	Newark, N. J.
15801	Federal Pacific Electric Co.	Hicksville, N. Y.
16299	General Instrument Corp. Semicon- ductor Prod. Group	Framingham, Mass.
	Fenwal Elect.	Raleigh, N. C.
	Corning Glass Works, Electronic Components Div.	

*Use Code 28480 assigned to Hewlett-Packard Co., Palo Alto, California

Table 6-3. Code List of Manufacturers (Continued)

CODE NO.	MANUFACTURER	ADDRESS	CODE NO.	MANUFACTURER	ADDRESS
16758	Delco Radio Div. of General Motors Corp.	Kokomo, Ind.	70563	Amperite Co. Inc.	Union City, N. J.
17545	Atlantic Semiconductors, Inc.	Asbury Park, N. J.	70901	Beemer Engrg. Co.	Fort Washington, Pa.
17803	Fairchild Camera and Instrument Corp	Semiconductor Div. Transducer Plant	70903	Belden Corp.	Chicago, Ill.
17870	Daven Div. Thomas A. Edison Industries	McGraw-Edison Co. Orange, N. J.	71218	Bud Radio, Inc.	Willoughby, Ohio
18324	Signetics Corp.	Sunnyvale, Calif.	71279	Cambridge Thermionic Corp.	Cambridge, Mass.
19315	Bendix Corp. The Navigation and	Control Div. Teterboro, N. J.	71400	Bussmann Mfg. Div. of McGraw &	Edison Co. St. Louis, Mo.
19701	Electra/Midland Corp.	Mineral Wells, Texas	71450	CTS Corp.	Elkhart, Ind.
21520	Fansteel Metallurgical Corp.	No. Chicago, Ill.	71468	I. T. T. Cannon Electric Inc.	Los Angeles, Calif.
22229	Union Carbide Corp. Electronics Div.	Mountain View, Calif.	71590	Globe-Union Inc.	Centralab Div. Milwaukee, Wis.
22753	UID Electronics Corp.	Hollywood, Fla.	71700	General Cable Corp. Cornish	Wire Co. Div. Williamstown, Mass.
23936	Pamotor, Inc.	Pampa, Texas	71707	Coto Coil Co. Inc.	Providence, R. I.
24446	General Electric Co.	Schenectady, N. Y.	71744	Chicago Miniature Lamp Works	Chicago, Ill.
24455	General Electric Co. Lamp Div. of Con-	sumer Prod. Group	71785	Cinch Mfg. Co. and Howard	B. Jones Div. Chicago, Ill.
24655	General Radio Co.	West Concord, Mass.	71984	Dow Corning Corp.	Midland, Mich.
24681	LTV Electrosystems Inc Memcor/Com-	ponents Operations Huntington, Ind.	72136	Electro Motive Mfg. Co. Inc.	Willimantic, Conn.
26982	Dynacool Mfg. Co. Inc.	Saugerties, N. Y.	72619	Dialight Corp.	Brooklyn, N. Y.
27014	National Semiconductor Corp.	Santa Clara, Calif.	72699	General Instrument Corp.	Newark, N. J.
28480	Hewlett-Packard Co.	Palo Alto, Calif.	72765	Drake Mfg. Co.	Harwood Heights, Ill.
28520	Heyman Mfg. Co.	Kenilworth, N. J.	72962	Elastic Stop Nut Div. of	Amerace Esna Corp. Union, N. J.
28875	IMC Magnetics Corp.	New Hampshire Div. Rochester, N. H.	72982	Erie Technological Products Inc.	Erie, Pa.
31514	SAE Advance Packaging, Inc.	Santa Ana, Calif.	73096	Hart Mfg. Co.	Hartford, Conn.
31827	Budwig Mfg. Co.	Ramona, Calif.	73138	Beckman Instruments Inc.	Hellpot Div. Fullerton, Calif.
33173	G. E. Co. Tube Dept.	Owensboro, Ky.	73168	Fenwal, Inc.	Ashland, Mass.
35434	Lectrohm, Inc.	Chicago, Ill.	73293	Hughes Aircraft Co. Electron	Dynamics Div. Torrance, Calif.
37942	P. R. Mallory & Co. Inc.	Indianapolis, Ind.	73445	Amperex Electronic Corp.	Hicksville, N. Y.
42190	Muter Co.	Chicago, Ill.	73506	Bradley Semiconductor Corp.	New Haven, Conn.
43334	New Departure-Hyatt Bearings Div.	General Motors Corp. Sandusky, Ohio	73559	Carling Electric, Inc.	Hartford, Conn.
44655	Ohmite Manufacturing Co.	Skokie, Ill.	73734	Federal Screw Products, Inc.	Chicago, Ill.
46384	Penn Engr. and Mfg. Corp.	Doylestown, Pa.	74193	Heinemann Electric Co.	Trenton, N. J.
47904	Polaroid Corp.	Cambridge, Mass.	74545	Hubbell Harvey Inc.	Bridgport, Conn.
49956	Raytheon Co.	Lexington, Mass.	74868	Amphenol Corp. Amphenol RF Div.	Danbury, Conn.
55026	Simpson Electric Co. Div. of American	Gage and Machine Co. Chicago, Ill.	74970	E. F. Johnson Co.	Waseca, Minn.
56289	Sprague Electric Co.	North Adams, Mass.	75042	IRC Div. of TRW, Inc.	Philadelphia, Pa.
58474	Superior Electric Co.	Bristol, Conn.	75183	*Howard B. Jones Div. of Cinch	Mfg. Corp. New York, N. Y.
58849	Syntron Div. of FMC Corp.	Homer City, Pa.	75376	Kurz and Xasch, Inc.	Dayton, Ohio
59730	Thomas and Betts Co.	Philadelphia, Pa.	75382	Kilka Electric Corp.	Mt. Vernon, N. Y.
61637	Union Carbide Corp.	New York, N. Y.	75915	Littlefuse, Inc.	Des Plaines, Ill.
63743	Ward Leonard Electric Co.	Mt. Vernon, N. Y.	76381	Minnesota Mining and Mfg. Co.	St. Paul, Minn.
			76385	Minor Rubber Co. Inc.	Bloomfield, N. J.
			76487	James Millen Mfg. Co. Inc.	Malden, Mass.
			76493	J. W. Miller Co.	Compton, Calif.

*Use Code 71785 assigned to Cinch Mfg. Co., Chicago, Ill.

Table 6-3. Code List of Manufacturers (Continued)

CODE NO.	MANUFACTURER	ADDRESS
76530	Cinch	City of Industry, Calif.
76854	Oak Mfg. Co. Div. of Oak	
	Electro/Netics Corp.	Crystal Lake, Ill.
77068	Bendix Corp., Electro-dynamics Div.	
		No. Hollywood, Calif.
77122	Palnut Co.	Mountainside, N. J.
77147	Patton-MacGuyver Co.	Providence, R. I.
77221	Phaostron Instrument and Electronic Co.	
		South Pasadena, Calif.
77252	Philadelphia Steel and Wire Corp.	
		Philadelphia, Pa.
77342	American Machine and Foundry Co.	
	Potter and Brumfield Div.	Princeton, Ind.
77630	TRW Electronic Components Div.	
		Camden, N. J.
77764	Resistance Products Co.	Harrisburg, Pa.
78189	Illinois Tool Works Inc. Shakeproof Div.	
		Elgin, Ill.
78452	Everlock Chicago, Inc.	Chicago, Ill.
78488	Stackpole Carbon Co.	St. Marys, Pa.
78526	Stanwyck Winding Div. San Fernando	
	Electric Mfg. Co. Inc.	Newburgh, N. Y.
78553	Tinnerman Products, Inc.	Cleveland, Ohio
78584	Stewart Stamping Corp.	Yonkers, N. Y.
79135	Waldes Kohinoor, Inc.	L. I. C., N. Y.
79377	Whitehead Metals Inc.	New York, N. Y.
79727	Continental-Wirt Electronics Corp.	
		Philadelphia, Pa.
79963	Zierick Mfg. Co.	Mt. Kisco, N. Y.
80031	Mepco Div. of Sessions Clock Co.	
		Morristown, N. J.
80294	Bourns, Inc.	Riverside, Calif.
81042	Howard Industries Div. of Msl, Ind. Inc.	
		Racine, Wisc.
81073	Grayhill, Inc.	La Grange, Ill.
81483	International Rectifier Corp.	
		El Segundo, Calif.
81751	Columbus Electronics Corp.	Yonkers, N. Y.
82099	Goodyear Sundries & Mechanical Co. Inc.	
		New York, N. Y.
82142	Airco Speer Electronic Components	
		Du Bois, Pa.
82219	Sylvania Electric Products Inc.	
	Electronic Tube Div. Receiving	
	Tube Operations	Emporium, Pa.
82389	Switchcraft, Inc.	Chicago, Ill.
82647	Metals and Controls Inc. Control	
	Products Group	Attleboro, Mass.
82866	Research Products Corp.	Madison, Wis.
82877	Rotron Inc.	Woodstock, N. Y.
82893	Vector Electronic Co.	Glendale, Calif.
83058	Carr Fastener Co.	Cambridge, Mass.
83186	Victory Engineering Corp.	
		Springfield, N. J.
83298	Bendix Corp. Electric Power Div.	
		Eatontown, N. J.
83330	Herman H. Smith, Inc.	Brooklyn, N. Y.
83385	Central Screw Co.	Chicago, Ill.
83501	Gavitt Wire and Cable Div. of	
	Amerace Esna Corp.	Brookfield, Mass.

CODE NO.	MANUFACTURER	ADDRESS
83508	Grant Pulley and Hardware Co.	
		West Nyack, N. Y.
83594	Burroughs Corp. Electronic	
	Components Div.	Plainfield, N. J.
83835	U. S. Radium Corp.	Morristown, N. J.
83877	Yardeny Laboratories, Inc.	
		New York, N. Y.
84171	Arco Electronics, Inc.	Great Neck, N. Y.
84411	TRW Capacitor Div.	Ogallala, Neb.
86684	RCA Corp. Electronic Components	
		Harrison, N. J.
86838	Rummel Fibre Co.	Newark, N. J.
87034	Marco & Oak Industries a Div. of Oak	
	Electro/netics Corp.	Anaheim, Calif.
87216	Philco Corp. Lansdale Div.	Lansdale, Pa.
87585	Stockwell Rubber Co. Inc.	
		Philadelphia, Pa.
87929	Tower-Olschan Corp.	Bridgeport, Conn.
88140	Cutler-Hammer Inc. Power Distribution	
	and Control Div. Lincoln Plant	
		Lincoln, Ill.
88245	Litton Precision Products Inc, USECO	
	Div. Litton Industries	Van Nuys, Calif.
90634	Gulton Industries Inc.	Metuchen, N. J.
90763	United-Car Inc.	Chicago, Ill.
91345	Miller Dial and Nameplate Co.	
		El Monte, Calif.
91418	Radio Materials Co.	Chicago, Ill.
91506	Augat, Inc.	Attleboro, Mass.
91637	Dale Electronics, Inc.	Columbus, Neb.
91662	Elco Corp.	Willow Grove, Pa.
91929	Honeywell Inc. Div. Micro Switch	
		Freeport, Ill.
92825	Whitso, Inc.	Schiller Pk., Ill.
93332	Sylvania Electric Prod. Inc. Semi-	
	conductor Prod. Div.	Woburn, Mass.
93410	Essex Wire Corp. Stemco	
	Controls Div.	Mansfield, Ohio
94144	Raytheon Co. Components Div.	
	Ind. Components Oper.	Quincy, Mass.
94154	Wagner Electric Corp.	
	Tung-Sol Div.	Livingston, N. J.
94222	Southco Inc.	Lester, Pa.
95263	Leecraft Mfg. Co. Inc.	L. I. C., N. Y.
95354	Methode Mfg. Co.	Rolling Meadows, Ill.
95712	Bendix Corp. Microwave	
	Devices Div.	Franklin, Ind.
95987	Weckesser Co. Inc.	Chicago, Ill.
96791	Amphenol Corp. Amphenol	
	Controls Div.	Janesville, Wis.
97464	Industrial Retaining Ring Co.	
		Irvington, N. J.
97702	IMC Magnetics Corp. Eastern Div.	
		Westbury, N. Y.
98291	Seaelectro Corp.	Mamaroneck, N. Y.
98410	ETC Inc.	Cleveland, Ohio
98978	International Electronic Research Corp.	
		Burbank, Calif.
99934	Renbrandt, Inc.	Boston, Mass.

Reference Designator	Description	Quantity	Mfr. Part # or Type	Mfr.	Mfr. Code	Stock No.	RS
C1	fxd, elect 1 μ f 35vdc	1	150D105X9035A2	Sprague	56289	0180-0291	1
C2	fxd, film 0.1 μ f 200vdc	1	192P10492	Sprague	56289	0160-0168	1
C3,13,21	fxd, film .033 μ f 200vdc	3	192P33392	Sprague	56289	0160-0163	1
C4	fxd, film 1 μ f 200vdc	1	260P10592S3	Sprague	56289	0160-2579	1
C5	fxd, film .22 μ f 80vdc	1	192P2249R8	Sprague	56289	0160-2453	1
C6,8	fxd, film .001 μ f 200vdc	2	192P10292	Sprague	56289	0160-0153	1
C7	fxd, film .068 μ f 200vdc	1	192P68392	Sprague	56289	0160-0166	1
C9	fxd, film .0047 μ f 200vdc	1	192P47292	Sprague	56289	0160-0157	1
C10,14	fxd, elect 20 μ f 50vdc	2	30D206G050DC4	Sprague	56289	0180-0049	1
C11,12, 15,22	NOT ASSIGNED	-	-	-	-	-	-
C16	fxd, elect 325 μ f 35vdc	1	D34656	HLAB	09182	0180-0332	1
C17,23	fxd, elect 1450 μ f 45vdc	2	D39532	HLAB	09182	0180-1893	1
C18B,25	fxd, ceramic .02 μ f 600vdc Dis 6	-	ED-.02	Erie	72982	0150-0024	1
C19	fxd, elect 1500 μ f 40vdc	1	D38733	HLAB	09182	0180-1894	1
C20	fxd, film .0022 μ f 200vdc	1	192P22292	Sprague	56289	0160-0154	1
C24	fxd, film 1 μ f 200vdc	1	118P10592S3	Sprague	56289	0160-2465	1
CR1,2,4, 8,9,16	Diode si. 250MW 200prv	6		HLAB	09182	1901-0033	6
CR3,5-7, 11,12,14, 15,17,18, 21,22	NOT ASSIGNED	-	-	-	-	-	-
CR10,13,20	Diode, si. 2.4V @ 100ma	3		HLAB	09182	1901-0460	3
CR19,23	Rect. si. 200ma 10prv	2		HLAB	09182	1901-0461	2
CR24-28,32	Rect. si. 500MA 200prv	6	1N3253	R. C. A.	02735	1901-0389	6
CR29,30B, 33,34	Rect. si. 1A 200prv	4	1N5059	G. E.	03508	1901-0327	4
CR30A	NOT USED	-	-	-	-	-	-
CR31	SCR 1.6A 50prv	1	C6F	G. E.	03508	1884-0033	1
DS1	Lamp neon part of S1 ass'y	Ref		HLAB	09182	2140-0244	1
F1	Fuse cartridge 1A @ 250V 3AG	1	312001	Littlefuse	75915	2110-0001	5
L1,2	Coil	2		HLAB	09182	9100-1854	1
Q1	Diff. Amp. NPN (oven ass'y)	1		HLAB	09182	1854-0021	1
Q2,3	SS NPN si. (oven ass'y)	2		HLAB	09182	1854-0027	2
Q4,6	NOT ASSIGNED	-	-	-	-	-	-
Q5	SS NPN si.	1	2N3390	G. E.	03508	1854-0202	1
Q7,8	SS PNP si.	2	2N2907A	Sprague	56289	1853-0099	2
Q9,10, 13-15	SS NPN si.	5		HLAB	09182	1854-0027	5
Q11	Power NPN si.	1		HLAB	09182	1854-0225	1
Q12	SS PNP si.	1	40362	R. C. A.	02735	1853-0041	1
Q16	Uni Junction si.	1	2N2446	G. E.	03508	1855-0010	1
R1,2	fxd, ww 1K Ω \pm 5% 3w	2	242E1025	Sprague	56289	0813-0001	1
R3	fxd, met. film 221K Ω \pm 1% 1/8w	1	Type CEA T-O	I. R. C.	07716	0757-0473	1
R4	fxd, met. film 27.4K Ω \pm 1% 1/8w	1	Type CEA T-O	I. R. C.	07716	0757-0452	1
R5,6	fxd, met. film 432K Ω \pm 1% 1/8w	2	Type CEA T-O	I. R. C.	07716	0757-0480	2
R7,8	fxd, met. film 43K Ω \pm 1% 1/8w	2	Type CEA T-O	I. R. C.	07716	0698-5090	2
R9	fxd, comp 120 Ω \pm 5% 1/2w	1	EB-1215	A. B.	01121	0686-1215	1

Reference Designator	Description	Quantity	Mfr. Part # or Type	Mfr.	Mfr. Code	Stock No.	RS		
R10,12,19	NOT USED	-	-	-	-	-	-		
R11,20, 51,58	NOT ASSIGNED	-	-	-	-	-	-		
R13,15	fxd, met. film 1 MEG ±1% 1/4w	2	Type CEB T-O	I. R. C.	07716	0757-0344	1		
R14,16	var. ww 15K Ω ±5% 1W@50°C	2	Model 100	I. R. C.	07716	2100-0896	1		
R17	fxd, ww 257 ±1% 1/4w	1		HLAB	09182	0811-1929	1		
R18	fxd, ww 5.9K ±1% 0±5%ppm/°C	1		HLAB	09182	0811-1978	1		
R21	fxd, met. film 2K ±1% 1/8w	1	Type CEA T-O	I. R. C.	07716	0757-0283	1		
R22	Thermistor 64 Ω ±10%	1	LB16J1	Fenwal	15801	0837-0023	1		
R23	fxd, ww 1 Ω ±.5% 8w	1	Type T-7A	R. C. L.	01686	0811-2133	1		
R24	fxd, comp 7.5K Ω ±5% 1/2w	1	EB-7525	A. B.	01121	0686-7525	1		
R25	var. ww 1K Ω ±5%	1		HLAB	09182	2100-1847	1		
R26,32,43	fxd, comp 10K Ω ±5% 1/2w	3	EB1035	A. B.	01121	0686-1035	1		
R27,28,33, 60	fxd, comp 1K Ω ±5% 1/2w	4	EB1025	A. B.	01121	0686-1025	1		
R29	fxd, comp 100 Ω ±5% 1/2w	1	EB-1015	A. B.	01121	0686-1015	1		
R30	fxd, comp 5.1K Ω ±5% 1/2w	1	EB-5125	A. B.	01121	0686-5125	1		
R31	fxd, comp 3.9K Ω ±5% 1/2w	1	EB-3925	A. B.	01121	0686-3925	1		
R34	fxd, comp 390 Ω ±5% 1/2w	1	EB-3915	A. B.	01121	0686-3915	1		
R35,59	fxd, comp 680 Ω ±5% 1/2w	2	EB-6015	A. B.	01121	0686-6815	1		
R36,61	fxd, comp 2K Ω ±5% 1/2w	2	EB-2025	A. B.	01121	0686-2025	1		
R37	fxd, comp 10 Ω ±5% 1/2w	1	EB-1005	A. B.	01121	0686-1005	1		
R38,45	fxd, comp 1.5K Ω ±5% 1/2w	2	EB-1525	A. B.	01121	0686-1525	1		
R39	fxd, met. ox 300 Ω ±5% 2w	1	Type C425	Corning	16299	0698-3630	1		
R40	fxd, ww 400 Ω ±5% 5w	1	Type 5XM	W. L.	63743	0811-1857	1		
R41	fxd, comp 200 Ω ±5% 1/2w	1	EB-2015	A. B.	01121	0686-2015	1		
R42	fxd, met. film 42.2 Ω ±1% 1/8w	1	Type CEA T-O	I. R. C.	07716	0757-0316	1		
R44	fxd, comp 4.3K Ω ±5% 1/2w	1	EB-4325	A. B.	01121	0686-4325	1		
R46,53	fxd, comp 2.7K Ω ±5% 1/2w	2	EB-2725	A. B.	01121	0686-2725	1		
R47,48	fxd, met. film 1.5K Ω ±1% 1/8w	2	Type CEA T-O	I. R. C.	07716	0757-0427	1		
R49	fxd, ww 714 Ω ±1% 1/4w	1		HLAB	09182	0811-1935	1		
R50	fxd, ww .24 Ω ±5%	1	Type BWH	I. R. C.	07716	0811-1758	1		
R52	fxd, comp 2.4K Ω ±5% 1/2w	1	EB-2425	A. B.	01121	0686-2425	1		
R54	fxd, ww 600 Ω ±5% 5w	1	Type 5XM	W. L.	63743	0811-1860	1		
R55	fxd, comp 33K Ω ±5% 1/2w	1	EB-3335	A. B.	01121	0686-3335	1		
R56,66	fxd, comp SELECTIVE ±5% 1/2w	2	Type EB	A. B.	01121		1		
R57	Thermistor 100K Ω ±10% (oven ass'y)	1	51TG4	Gulton	90634	0837-0026	1		
R62	fxd, comp 220 Ω ±5% 1/2w	1	EB-2215	A. B.	01121	0686-2215	1		
R63	fxd, ww .51 ±5%	1	Type BWH	I. R. C.	07716	0811-0929	1		
R64	fxd, met. film 1.21K ±1% 1/8w	1	Type CEA T-O	I. R. C.	07716	0757-0274	1		
R65	var. ww 10 Ω	1	Type 110-F4	C. T. S.	11236	2100-1822	1		
R67	var. ww 1K	1	Type 110-F4	C. T. S.	11236	2100-0391	1		
R68	fxd, comp 560 ±5% 1/2w	1	EB-5615	A. B.	01121	0686-5615	1		
R69	fxd, met. film 19.1K ±1% 1/8w	1	Type CEA T-O	I. R. C.	07716	0698-4484	1		
S1	Switch, pilot lt. (red) ON/OFF	1	54-61681 - 26 A1H	Oak	87034	3101-0100	1		
S2	Meter switch, wafer	1		HLAB	09182	3100-1900	1		
S3	Thumbwheel switch	1	See parts listed below marked with an *					06111-60001	1
R200*	var. ww 10 Ω	1		HLAB	09182	2100-1887	1		
R201-209*	fxd, ww 10 Ω ±0.25% 1/4w 20ppm	9	Type E-20	R. C. L.	01686	0811-1958	2		
R211-219*	fxd, ww 100 Ω ±0.1% 1/4w 10ppm	9	Type E-20	R. C. L.	01686	0811-1968	2		
R221-229*	fxd, ww 1K Ω ±0.1% 1/4w 5ppm	9	Type E-20	R. C. L.	01686	0811-1976	2		
R231*	fxd, ww 10K Ω ±0.1% 1/2w 5ppm	1	Type E-30	R. C. L.	01686	0811-1994	1		
S201-204*	Rotary switch 10 pos. SPKEL-F	4		HLAB	09182	3100-1902	1		

Reference Designator	Description	Quantity	Mfr. Part # or Type	Mfr.	Mfr. Code	Stock #	RS
	5 Way binding post (maroon)	1	DF21MN	HLAB	09182	0510-0040	1
	5 Way binding post (black)	2	DF21BC	Superior	58474	0510-0039	1
	Cable clamp $\frac{1}{4}$ I. D.	1	T4-4	Whitehead	79307	1400-0330	1
	Line cord, plug PH151 $7\frac{1}{2}$ ft.	1	KH-4096	Beldon	70903	8120-0050	1
	Strain relief bushing	1	SR-5P-1	Heyco	28520	0400-0013	1
	Knob; $\frac{1}{4}$ insert pointer	2		HLAB	09182	0370-0084	1
	Jumper	5	4221-13-11 013	Cinch	71785	0360-1274	1
	Heat Dissipator	1	NF-207	Wakefield	05820	1205-0033	1
	Barrier strip	1		HLAB	09182	0360-1234	1
	Rubber bumper	4	MB50	Stockwell	87575	0403-0088	1
	Rubber bumper	3	4072	Stockwell	87575	0403-0086	1
	Bezel 1/6 mod.	1		HLAB	09182	4040-0295	1
	Fuse holder	1	342014	Littlefuse	75915	1400-0084	1
	Meter, $2\frac{1}{4}$ ", DUAL0-50V, 0-.6A	1		HLAB	09182	1120-1152	1
	Meter spring	4		HLAB	09182	1460-0720	1
	Fastener	8	C8091 632-24B	Tinnerman	89032	0510-0275	2
	Captive nut	8	CLA-632-2	Pem. Eng.	46384	0590-0393	2
	Mica Insulator	1	734	Reliance	08530	0340-0174	1
	Insulator, transistor pin	2		HLAB	09182	0340-0166	1
	Insulator	2		HLAB	09182	0340-0168	1

OPTION 06:

	Overvoltage "Crowbar" Protector Model 6916A	1	-	HLAB	09182	Model 6916A	
--	---	---	---	------	-------	-------------	--

APPENDIX A
Option 11, Over Voltage Protection "Crowbar"

DESCRIPTION:

This option is installed in DC Power Supplies, 6101A, 6102A, 6106A, 6111A, 6112A, 6113A, and 6116A, and tested at the factory. It consists of a printed circuit board, screwdriver-type front panel potentiometer, and four wires that are soldered to the main power supply board.

The crowbar monitors the output voltage of the power supply and fires an SCR that shorts the output when it exceeds the preset trip voltage. The trip voltage is determined by the setting of the CROWBAR ADJUST control on the front panel. The trip voltage range is as follows:

Model	6101A	6102A	6106A	6111A	6112A	6113A	6116A
Trip Voltage Range	3.2-23V	3.2-44V	20-110V	3.2-23V	3.2-44V	3.2-13V	20-110V

To prevent transients from falsely tripping the crowbar, the trip voltage must be set higher than the power supply output voltage by the following margin: 7% of the output voltage +1V. The margin represents the minimum crowbar trip setting for a given output voltage; the trip voltage can always be set higher than this margin.

OPERATION:

1. Turn the CROWBAR ADJUST fully clockwise to set the trip voltage to maximum.
2. Set the power supply VOLTAGE control for the desired crowbar trip voltage. To prevent false crowbar tripping, the trip voltage should exceed the desired output voltage by 7% of the output voltage +1V.
3. Slowly turn the CROWBAR ADJUST counterclockwise until the crowbar trips, and the output falls to a small positive voltage (about 1.8V or less).
4. The crowbar will remain activated and the output shorted until the supply is turned off. To reset the crowbar, turn the supply off, then on.

Table A-1. Replaceable Parts

REF. DESIG.	DESCRIPTION	TQ	MFR. PART NO.	MFR. CODE	HP PART NO.	RS
C1	fxd, elect 1 μ F 50Vdc	1	30D105G050BA2	56289	0180-0108	1
C2	fxd, mica 510 μ F 500Vdc	1	RCM15E51IJ	04062	0140-0047	1
CR1-3	Diode, Si, 200mA 200prv	3		09182	1901-0033	3
CR4	SCR 7.4A 100prv	1	C20A	03508	1884-0031	1
Q1, 2	SS NPN Si,	2	2N3417	03508	1854-0087	2
R1	fxd, met. film 10 Ω \pm 1% 1/8W	1	Type CEA T-O	07716	0757-0346	1
R2	fxd, comp 1.3K \pm 5% 1W	1	GB-1325	01121	0689-1325	1
R3	fxd, met. film 1.21K Ω \pm 1% 1/8W	1	Type CEA T-O	07716	0757-0274	1
R4	fxd, met. film 7.5K Ω \pm 1% 1/8W	1	Type CEA T-O	07716	0757-0440	1
R5	var. ww 10K Ω \pm 5% (CROWBAR ADJ.)	1		09182	2100-1854	1
R6	var. ww 1K Ω \pm 5% 3W	1	242E1025	56289	0813-0001	1
R7	fxd, comp 22 Ω \pm 5% $\frac{1}{2}$ W	1	EB-2205	01121	0686-2205	1
R8	fxd, met. film 510 Ω \pm 1% $\frac{1}{2}$ W	1	Type CEB T-O	07716	0698-5145	1
T1	Transformer, Pulse	1		09182	5080-7122	1
VR1	Diode, zener 6.19V \pm 5%	1		09182	1902-0049	1
VR2	Diode, zener 2.37V \pm 5%	1		09182	1902-3002	1
	MISCELLANEOUS					
	Heat Sink, CR4	1		09182	5000-6229	
	Insulator, CR4	1		09182	0340-0462	
	Mica Washer, CR4	1		09182	2150-0709	
	Cable Clamp	1	T4-4	79307	1400-0320	
	Bushing, Potentiometer (R5)	1		09182	1410-0052	
	Nut, Hex (R5)	1		09182	2950-0034	
	Label, Information, (CROWBAR ADJUST)	1		09182	7124-0389	
	Modified Front Panel, Includes Components	1		09182	06111-60005	
	Printed Circuit Board Assembly, Includes Components	1		09182	06101-60021	

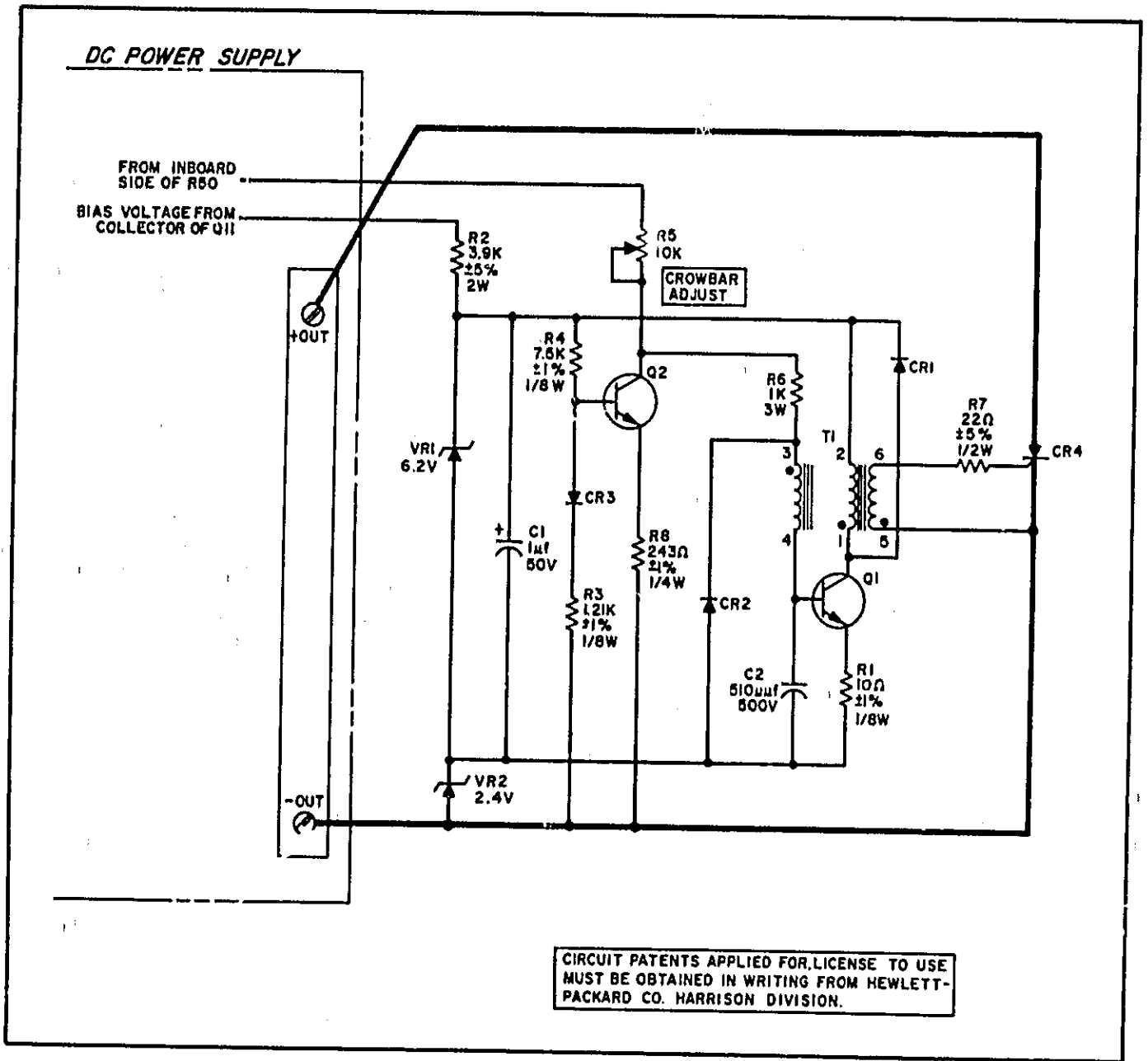
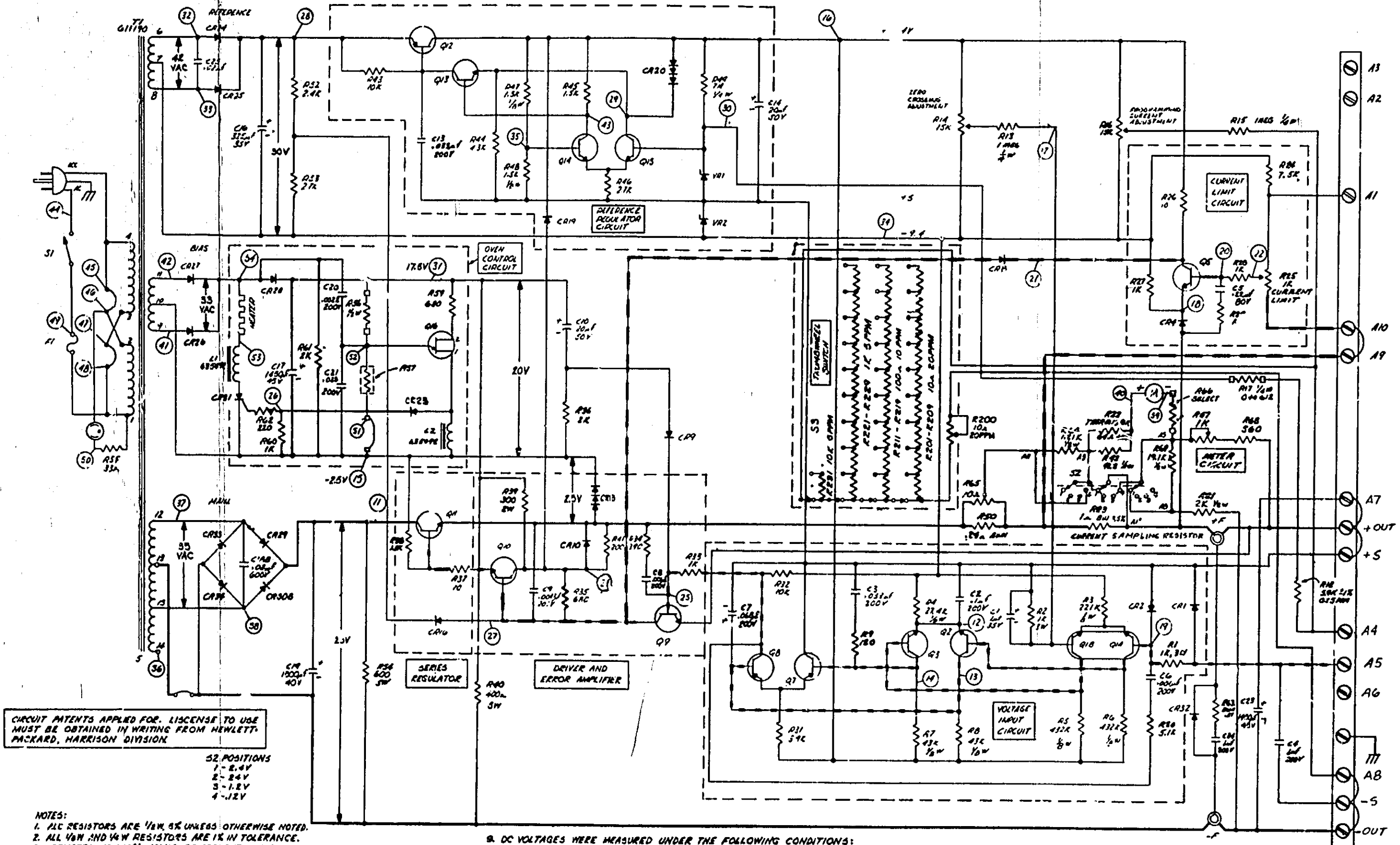

Figure A-1. Model 6102A and 6112A Overvoltage Protection Crowbar



CIRCUIT PATENTS APPLIED FOR. LICENSE TO USE MUST BE OBTAINED IN WRITING FROM HEWLETT-PACKARD, HARRISON DIVISION

- 52 POSITIONS
 1 - 2.4V
 2 - 2.4V
 3 - 1.2V
 4 - 1.2V

- NOTES:
 1. ALL RESISTORS ARE 1/8W, 5% UNLESS OTHERWISE NOTED.
 2. ALL 1/8W AND 1/4W RESISTORS ARE 1% IN TOLERANCE.
 3. + DENOTES NOMINAL VALUE, COMPONENTS SELECTED FOR OPTIMUM PERFORMANCE.
 4. # DENOTES 20PPM WIRE TEMPERATURE COEFFICIENT.
 5. REAR TERMINALS ARE SHOWN IN NORMAL STRAPPING.
 6. — DENOTES VOLTAGE FEEDBACK SIGNAL.
 7. — DENOTES CURRENT FEEDBACK SIGNAL.
 8. TRANSFORMER SHOWN STRAPPED FOR 115VAC OPERATION. SEE INSTRUCTION MANUAL FOR 220 VAC.

9. DC VOLTAGES WERE MEASURED UNDER THE FOLLOWING CONDITIONS:
 A. SIMPSON MODEL 200 OR EQUIVALENT.
 B. 115 VAC INPUT.
 C. VOLTAGES REFERENCED TO +S UNLESS OTHERWISE NOTED.
 D. VOLTAGES ARE TYPICAL, ±10% UNLESS OTHERWISE NOTED.
 E. SUPPLY IN CONSTANT VOLTAGE OPERATION AT MAXIMUM RATED OUTPUT WITH NO LOAD CONNECTED. CURRENT CONTROLS SHOULD BE TURNED FULLY CLOCKWISE.

Model 6111A, Schematic Diagram

MANUAL CHANGES
Model 6111A DC Power Supply
Manual HP Part No. 06111-90001

Make all corrections in the manual according to errata below, then check the following table for your power supply serial number and enter any listed change(s) in the manual.

SERIAL		MAKE CHANGES
Prefix	Number	
All	—	Errata
6E	0172-0211	1
7A	0212-0656	1, 2
7A	0657-0681	1, 2, 3
7A	0682-0746	1, 2, 3, 4
1B	0747-0856	1 thru 5
1140A	0857-0936	1 thru 6
1140A	0937-1061	1 thru 7
1140A	1062-1586	1 thru 8
1606A	1687-2096	1 thru 9
1735A	2097-2416	1 thru 10
1930A	2417-2456	1 thru 11
1934A	2457-2906	1 thru 12
2125A	2907-up	1 thru 13

ERRATA:

On the schematic at the rear of manual, add jumper between terminals A4 and A5 on rear terminal strip.

In the replaceable parts table, make the following changes:

Q7, Q8: Change to 2N2907A, Sprague, 56289, HP Part No. 1853-0099, SS PNP Si.

R64: 3.6 Meg. $\pm 5\%$, 1/2W, A. B., HP Part No. 0686-3655.

In Paragraph 4-23, third sentence, change "C23" to "CR23."

On Page 5-11, Table 5-8, make the following changes:

Zero Volt Programming Accuracy: Change "R6 or R8" to R14.

Programming Current Level: Change "R13" to R16, R17.

CHANGE 1:

On Page 5-10, Table 5-6, delete references Q2 and Q3 from the first column of table.

In the replaceable parts table, make the following change:

Q2, Q3: Change type to 2N3391, HP Part No. 1854-0371, SS NPN Si., G. E. 03508.

On the schematic at the rear of the manual, delete the lead connecting terminal 13, in the main secondary of T1, to the junction between anodes of CR33 and CR34. Terminal 13 should now be open and the anodes of CR33 and CR34 should be left connected to the minus side of filter capacitor C19.

CHANGE 2:

The serial number prefix of the instrument has been changed from "6E" to "7A".

In the replaceable parts table and on the schematic (if applicable) make the following changes:

R201-R209: Change tolerance to $\pm 0.1\%$ and temp. coeff. to 10ppm/ $^{\circ}$ C.

VR1: Change to HP Part No. 1902-1221, 6.2V, $\pm 5\%$. 250mW zener, 1N821, Transltron 03877.

CHANGE 3:

In the replaceable parts table and on the schematic diagram, make the following change:

CR13: Change to three discrete diodes, CR5, CR6, and CR7, each HP Part No. 1901-0327 (1N5059).

CHANGE 4:

In the replaceable parts table, make the following changes:

S1: Change to HP Part No. 3101-124B.

Terminal Strip: Add, HP Part No. 0360-0401.

CHANGE 5:

In the replaceable parts table and on the schematic, make the following changes:

Power Transformer T1: Change to HP Part No. 5080-7181.

R51: Add, 20 Ω , 1/2W, HP Part No. 0386-2005. R51 is added between C4 and -S terminal on schematic.

CHANGE 6:

The serial prefix of this unit has been changed to 1140A. This is the only change.

ERRATA:

Delete references to Option 06 on pages 4-1, 1-2, and 6-7.

Option 06 has been superseded by Option 011.

When supply is shipped with Option 011, Overvoltage Protection Crowbar Installed, Appendix A, Figure A-1 is added to the schematic diagram.

CHANGE 7:

The standard colors for this instrument are now mint gray (for front and rear panels) and olive gray (for all top, bottom, side, and other external surfaces). Option X95 designates use of the former color scheme of light gray and blue gray. Option AB5 designates use of a light gray front panel with olive gray used for all other external surfaces. New part numbers are shown on back.

CHANGE 8:

In the replaceable parts table and on the schematic, make the following changes:

R13: Change to 562k Ω , 1/8W, HP Part No. 0757-0483.

R24: Change to 5.1k Ω , $\pm 5\%$, 1/2W, HP Part No. 0686-5125.

R58: Add R58, var, ww, 5k Ω , $\pm 5\%$, HP Part No. 2100-0741.

R58 is added as follows:

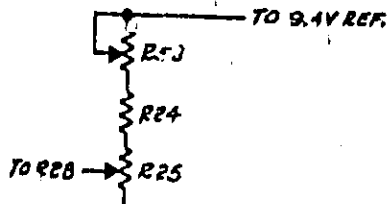

The above changes have been made to allow for Option 040 (multiprogrammer remote programming) operation; to allow the current limit to be set to $110 \pm 2\%$ of rated current.

ERRATA:

- In Table 1-1, Load Regulation should read:
 Front Terminals: Less than 0.001% plus $700\mu\text{V}$.
- In the parts list make the following changes:
 Change the HP Part No. of S2 to 3100-1911.
 Change the HP Part No. of rubber bumper 0403-0088 to 0403-0002.
- In Table A-1, change the HP Part No. of CR4 to 1884-0032.

CHANGE 8:

In the replaceable parts table and on the schematic, make the following changes:

- R60: Delete.
- R62: Change to 1k, 5%, 1/2W, HP Part No. 0686-1025.
- CR23: Change to HP Part No. 1901-0033 and connect in shunt with L2 as shown below.

On the schematic, change the oven control circuit as shown below.

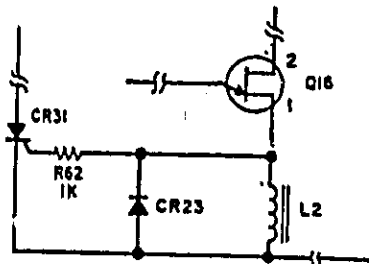

This change reduces the magnetic radiation induced in the oven control circuit to ensure a ripple specification of $100\mu\text{V}$ peak-to-peak.

ERRATA:

Add the following notice to paragraph 1-16: "Effective December 1, 1975, extra manuals may be obtained by ordering Option 910 when ordering your instrument. The number of extra manuals depends on the number of Option 910's ordered."

Add to the parts list the replacement lamp for illuminated switch 3101-1248, which is used in those supplies that include Change 4. The HP Part No. of the type A1H lamp is 2140-0244.

The front panel binding posts have been changed to a type with better designed insulation. Delete the two types of posts listed on page 6-7 of the parts list and add: black binding post, HP Part No. 1510-0114 (qty. 2); and red binding post, HP Part No. 1510-0115 (qty. 1).

The blue-gray meter bezel has been replaced by a blank one, HP Part No. 4040-0414.

Add the following to the parts list: corrugated packing carton, HP Part No. 9211-0615; and two floater pads, 9220-1418.

Change the part number of R58 (added to the current limit circuit by Change 8) to 2100-3252. The resistor has not been changed; just its part no. has.

CHANGE 10:

Change zener diode VR2 to 9V, 0.005% T.C., HP Part No. 1902-0785. Note that the old zener diode (1902-0763) should not be used for replacement at any time.

ERRATA:

In Table 1-1, change the Transient Recovery Time Specification to read as follows:

Less than $50\mu\text{ sec}$ is required for output voltage recovery to within 50mV of the nominal output voltage following a change in output current equal to the current rating of the supply, when the input line voltage is at 115Vac or 230 Vac.

For all instruments delivered on or after July 1, 1978, change the HP Part No. for fuseholder from 1400-0084 to fuseholder body 2100-0564 and fuseholder carrier 2100-0565. Change the HP Part No. for fuseholder nut from 2950-0038 to 2110-0569. If old fuseholder must be replaced for any reason, replace complete fuseholder and nut with new fuseholder parts. Do not replace new parts with old parts.

DESCRIPTION	HP PART NO.		
	STANDARD	OPTION A85	OPTION X95
Front Panel, Lettered	06111-60006	06111-60003	←
Chassis, Left Side	5000-9430	←	5000-6094
Chassis, Right Side	5000-9429	←	5000-6093
Trim Strip	5000-9489	←	5000-6199
Cover	5000-9424	←	5000-6061
Heat Sink	5060-7966	←	5060-6124

CHANGE 11:

In the parts list, change the HP Part No. for the binding posts, control knobs, and associated hardware to the following:

Red binding post, qty 2 : 1510-0091

Terminal lug, qty 2 : 0360-0042

Lockwasher, qty 2: 2190-0079

Nut, qty 1 : 2500-0001

Black binding post, qty 1 : 1510-0107

Terminal lug, qty 1 : 0360-1190

Nut, qty 3 : 2950-0144

Knob, pointer, qty 2: 0370-1099

Resistor, var 1k, R67, qty 1: 2100-3281

Lockwasher, qty 12: 2190-0016

CHANGE 12

In the replaceable parts list, change Switch S1 to HP Part No. 3101-2287 and change Terminal Strip (added in Change 4) to HP Part No. 0360-0015. On the schematic diagram change Switch S1 to show two switch sections, one which breaks the AC line (as shown), the other breaks the ACC line.

In the replaceable parts list change the description of S1 to: ON/OFF. On page 3-1 figure 3-1 change reference point 1 to: LINE SWITCH and change Note 1 to: Push Line switch to turn on supply.

ERRATA:

In the replaceable parts list, change Q1 to HP P/N 1854-0221.

► In the replaceable parts list and on the schematic change the variable resistors R114 and R116 to 20k Ω $\frac{1}{2}$ W HP Part No. 2100-0558.

CHANGE 13:

In the replaceable parts list change Terminal Strip (Added in Change 12) to HP Part No. 0360-0011.

10-31-81