



**INTERFERENCE
PRODUCT GUIDE**

Q1, 2022



TABLE OF CONTENTS

1	COMPANY OVERVIEW	4-5
2	TESTING CAPABILITIES	6-7
3	EXTERNAL PIM OVERVIEW	8-11
4	PIM HUNTING	12-17
5	BARRIER MATERIALS	18-23
6	LOW PIM CABLE HANGERS	24-29
7	THREADED ROD KITS	30-33
8	NON-METALLIC SUPPORTS	34-39
9	METALLIC SUPPORTS	40-43
10	RAIL SYSTEM	44-49
11	INSTALLATION TOOLS	50-53
12	BACKLOBE SUPPRESSORS	54-58
13	SALES CONTACT INFORMATION	59



Company Overview

Since we began in 2007, we've stayed true to our values – being highly responsive to the industry's evolving needs for solutions-engineered products, fast site approvals, and rapid deployments. We've delivered on these values by partnering with global OEMs and operators, focusing on engineering excellence, and housing our engineering, manufacturing, testing, and fulfillment operations together from our 160,000 ft.² facility headquarters in Colorado Springs, CO.

Today we are an Inc. 5000 fastest growing company, and our small cell concealment products line city and venues across North America and our PIM Shield® interference mitigation products can be found on towers across the world. Our focus on engineering excellence ensures our products deliver optimum coverage and capacity, can weather everything from hurricane strength winds to seismic events, and are structurally, RF, and thermally tested to Telcordia standards.

Whether outfitting an entire venue with 5G capability, planning materials to build or retrofit small cell sites, or seeking an end-to-end solution for testing and mitigating PIM, ConcealFab is the answer.

WE'RE LEADING 5G INNOVATION.

**Inc.
5000**

platinum
REGISTRATION, INC.
**ISO 9001:2015
CERTIFIED**

Testing Capabilities

RADIATED PIM TESTING

ConcealFab has a purpose built anechoic chamber designed for performing radiated PIM tests in accordance with IEC 62037-8. ConcealFab can perform product certification tests at 600 MHz, 700 MHz, 850 MHz, 1900 MHz and 2100 MHz using test equipment from Anritsu and Kaelus.

MATERIAL TESTING

ConcealFab can characterize the performance of concealment materials from 1 GHz to 40 GHz in the same anechoic chamber. Capabilities include both near field and far field transmission loss measurements as well as antenna pattern measurements. ConcealFab owns a 28 GHz Anokiwave phased array antenna for measuring antenna pattern performance at mmW frequencies.







External PIM Overview

External PIM Overview



Scan Here For PIM Hygiene Application Note

COMMON SOURCES OF EXTERNAL PIM

Passive intermodulation (PIM) is a form of interference created when downlink signals at a cell site mix at “non-linear” objects in the RF path. Any loose metal-to-metal contact or dissimilar metal contact in front of or in the reactive near field behind an antenna can generate PIM. Using ConcealFab’s test and measurement solutions many sources of external passive intermodulation (PIM) have been identified at cell sites.

METAL OBJECTS IN FRONT OF ANTENNAS

Cable trays, air handling units, sky lights and vent pipes are just a few of the metal objects commonly found on rooftops in front of base station antennas. Many of these items are made from sheet metal with loosely touching metal-to-metal surfaces.



ROOFING MATERIALS / CONSTRUCTION

Roofs are engineered to prevent water ingress and provide thermal insulation for buildings. They are not designed with PIM in mind. Some of the common problems found include overlapping steel deck members, plates and screws used to secure insulation and over-lapping sheet metal used for flashing. Many of these issues are below the roof membrane and invisible by just looking at the roof.



GALVANIC CORROSION

Stainless steel and galvanized steel are at opposite ends of the galvanic series and small pockets of corrosion will form where these materials touch. These corrosion pockets do not present a structural concern, but they do generate significant PIM when close to base station antennas.



METAL SNAP-IN HANGERS

Metal snap-in style cable hangers are very convenient given they require no tools for installation. Unfortunately, the loosely touching metal-to-metal interfaces between hangers are prime sources of PIM, as are the galvanic corrosion pockets created when hangers are attached to galvanized steel support brackets.

HOSE CLAMPS

Stainless steel hose clamps are deployed by the thousands in wireless infrastructure to secure cable support brackets. Unfortunately, the galvanic mismatch between the stainless-steel banding and galvanized steel pipe generates PIM. Hose clamps also have a “tail” that can lightly touch other steel members and cause PIM.

METAL STRUT FASTENERS

Metal strut is used at cell sites to support a wide variety of objects including RF cables, radios and fiber distribution boxes. While the strut itself is generally low PIM, the interfaces between the strut and just about every other metal object is not low PIM. Nut retaining springs, snap-in stainless-steel fasteners, bolted connects between struts and connections between the strut and round members at sites can all be sources of PIM.



ANGLE ADAPTERS

Galvanized steel angle is commonly used as a structural member on both rooftop sites and tower sites. Angle adapters are deployed along the length of these angles to secure RF, power, RET and fiber cables. PIM is generated by the galvanic mismatch between stainless-steel angle adapters and galvanized steel angle. PIM also occurs where the stainless-steel set screw digs into the galvanized steel surface.



PIM SHIELD® PRODUCTS FROM CONCEALFAB

PIM Shield® is a family of products developed by ConcealFab that reduce external PIM at cell sites. These products eliminate PIM by doing one or more of the following:

ELIMINATE GALVANIC MISMATCHES AT JUNCTIONS

Galvanic mismatches can be eliminated by making sure the same metal & finish is used on both sides of a junction.

ENSURE HIGH CONTACT PRESSURE AT JUNCTIONS

It is perfectly fine for metal to touch metal as long as the junction between parts is designed to maintain high contact pressure. Large contacting surfaces should be avoided.

INSULATE JUNCTIONS

If high contact pressure between metal parts can't be guaranteed, or galvanic mismatches prevented, insulate the parts to prevent electrical contact.

BLOCK RF FROM REACHING THE JUNCTION

If a metal to metal junction can't be fixed using one of the above methods, Install a RF barrier material to prevent RF energy from reaching the non linear junction.





PIM Hunting

PIM Hunting

PIM PROBE

The PIM test probe is used in conjunction with other test and measurement equipment to precisely locate external PIM sources in the field. Once PIM locations are identified, mitigation materials available from ConcealFab can be applied to reduce the PIM levels and improve site performance.



007320-01
Part Number



CERTIFICATION TRAINING

ConcealFab offers an intense one-day instructor led training course to teach wireless professionals how to precisely locate and mitigate external PIM at cell sites. The course uses a combination of theory and practical, hands-on exercises to build user confidence.

EXTERNAL PIM SOURCES

Key Features

- Diode based PIM source
- Optimized for sub-1 GHz performance
- 900643 includes RF shielded pouch for field use
- 900645 is an isotropic source for lab use



900643
Part Number

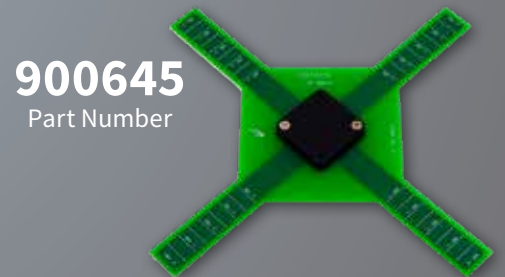

900645
Part Number



900644-10
Part Number | Qty. 10



900644-100
Part Number | Qty. 100

CONNECTOR CLEANING TOOLS

Key Features

- Use with alcohol wipes
- 7-16 and 4.3-10 series RF connectors

PIM BLANKETS

ConcealFab's PIM blankets are temporary RF barriers that can be deployed to help isolate sources of passive intermodulation (PIM). When a PIM blanket is placed over an external PIM source, PIM from that source is typically reduced by >30 dB.

Key Features

- Low PIM
- High RF attenuation
- Heavy duty vinyl construction
- Integrated tie-down loops (see table)



Scan Here
For PIM Blanket Kits



Part Number	Length	Width	Loops	Corners
007640-120060	120 in (3.05 m)	60 in (1.52 m)	6	Rounded
007640-060060	60 in (1.52 m)	60 in (1.52 m)	4	Rounded
007640-060030	60 in (1.52 m)	30 in (0.75 m)	4	Rounded
007640-030030	30 in (0.75 m)	30 in (0.75 m)	4	Rounded

PIM Blanket kits with an assortment of blankets and transit case are available

PIM SHIELD® FOIL

PIM Foil is a light weight, temporary RF barrier material that can be deployed at cell sites to help isolate PIM. PIM Foil is 1/10th the weight of ConcealFab's durable PIM Blankets making it easier and faster to cover large areas at rooftop cell sites. Not recommended for wind speeds > 10 mph. A soft case is available for storing and transporting PIM Foil material.



Scan Here
For PIM Shield® Foil



Part Number	Description
900964-18-100	PIM Foil, 18-Inch x 100-FT Roll
900964-36-100	PIM Foil, 36-Inch x 100-FT Roll
900964-KIT-101	PIM Foil Kit, 3x 36-Inch, 2x 18-Inch (includes soft case)
901067	PIM Foil Soft Case

PIM Absorber Kit

PIM ABSORBER KITS

The front PIM Absorber kit is a Patent Pending low PIM blanket assembly designed to be secured to the front face of base station antennas. The front absorber kit suppresses forward radiation from the antenna with minimum PIM generation and minimum reflection back into the antenna feed system. The front PIM Absorber kit can be used with ConcealFab's rear PIM Absorber kit (901125) to help determine the direction of external PIM sources relative to site antennas. Back PIM Absorber kit panels are designed to be installed between the back of a base station antenna and the antenna mounting pipe. The back absorber panels suppress rear radiation from the antenna with minimum PIM generation.

FRONT ABSORBER KIT

901124
Part Number



REAR ABSORBER KIT

901125
Part Number



PIM TEST TROLLEY

The PIM Test Trolley provides a lightweight yet stable antenna mounting mast for use when measuring PIM at candidate rooftop cell sites. Large pneumatic wheels enable the trolley to be rolled across typical roof membranes without damaging the roof surface.

901134
Part Number







Barrier Materials

Barrier Materials

PIM SHIELD® TAPE

PIM Shield® tape is a rapidly deployable RF barrier able to bond to a wide variety of surfaces including metals, single-ply roofing, multi-ply roofing, concrete, brick and wood. The tape's highly compliant synthetic resin adhesive enables strong bonds to irregular surfaces. See installation instructions for surface preparation requirements.

Key Features

- Low PIM
- High RF attenuation
- UV stable TPO outer protective layer
- High tack synthetic resin adhesive
- Silicone release liner

Part Number	Roll Width	Roll Length	Color
008587-06-25-W	6 - Inch	25 ft.	White
008587-06-25-B	6 - Inch	25 ft.	Black
008587-12-25-W	12 - Inch	25 ft.	White
008587-12-25-B	12 - Inch	25 ft.	Black



PIM SHIELD® ROOFING

ConcealFab has partnered with Johns Manville, a global leader in the roofing industry, to co-develop reliable roofing materials able to mitigate passive intermodulation at cell sites.

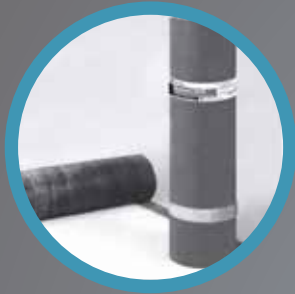

PIM Shield® roofing is a multi-ply Styrene-Butadiene-Styrene (SBS) modified bitumen roof membrane sold exclusively through ConcealFab. The material includes ceramic coated granules on the top surface for solar reflectivity and membrane protection. An internal PIM Shield® layer bonded between two SBS modified bitumen layers form a water-tight RF barrier able to provide decades of PIM protection.

Part Number	Description	Granules	Application Method
DL180FRPIM	DynaLastic 180 FR PIM, 10 m x 1 m roll	S	HA, CA
DL180FRCRGPIM	DynaLastic 180 FR CR G PIM, 10 m x 1 m roll	HR	HA, CA

*Granules: S = Standard, HR = High Reflectivity
Application Method: HA = Hot Asphalt, CA = Cold Adhesive*



PIM Mitigation Paint

PIM SHIELD® PIM MITIGATION PAINT

PIM Shield® PIM mitigation paint is a conductive acrylic polymer with enhanced elasticity designed to reduce external passive intermodulation (PIM) at cellular base stations. PIM Shield® paint is intended for large, flat surfaces and should NOT be applied directly to antenna mounting structures. Use PIM Seal™ Conductive Caulk to reduce PIM at metal-to-metal contacts on antenna mounting structures.

Key Features

- Low PIM
- High RF Attenuation
- Crack Resistant
- UV stable Acrylic
- Water based
- Non-flammable



Part Number	Description	Qty. Per Case	Case Weight (lbs.)	Case Dimensions (inches)
901087-0	PIM Shield PIM Mitigation Paint, 1 Quart	6	15.9	13.5 x 9.3 x 5.5
901087-1	PIM Shield PIM Mitigation Paint, 1 Gallon	4	41	14 x 14 x 8.5

PIM Mitigation Caulk

PIM SEAL™ PIM MITIGATION CAULK

PIM Seal™ PIM mitigation caulk is a thickened version of PIM Paint that can be used to fill gaps and seal RF from reaching PIM sources generated at contacting surfaces. Like PIM Paint, PIM Seal™ PIM mitigating caulk forms a highly elastic seal that resists cracking over a wide range of temperature extremes.



Part Number	Description	Qty. Per Case	Case Weight (lbs.)	Case Dimensions (inches)
901088	PIM Seal PIM Mitigation Caulk, 10.5 oz tube	12	11.6	6.3 x 8.3 x 12

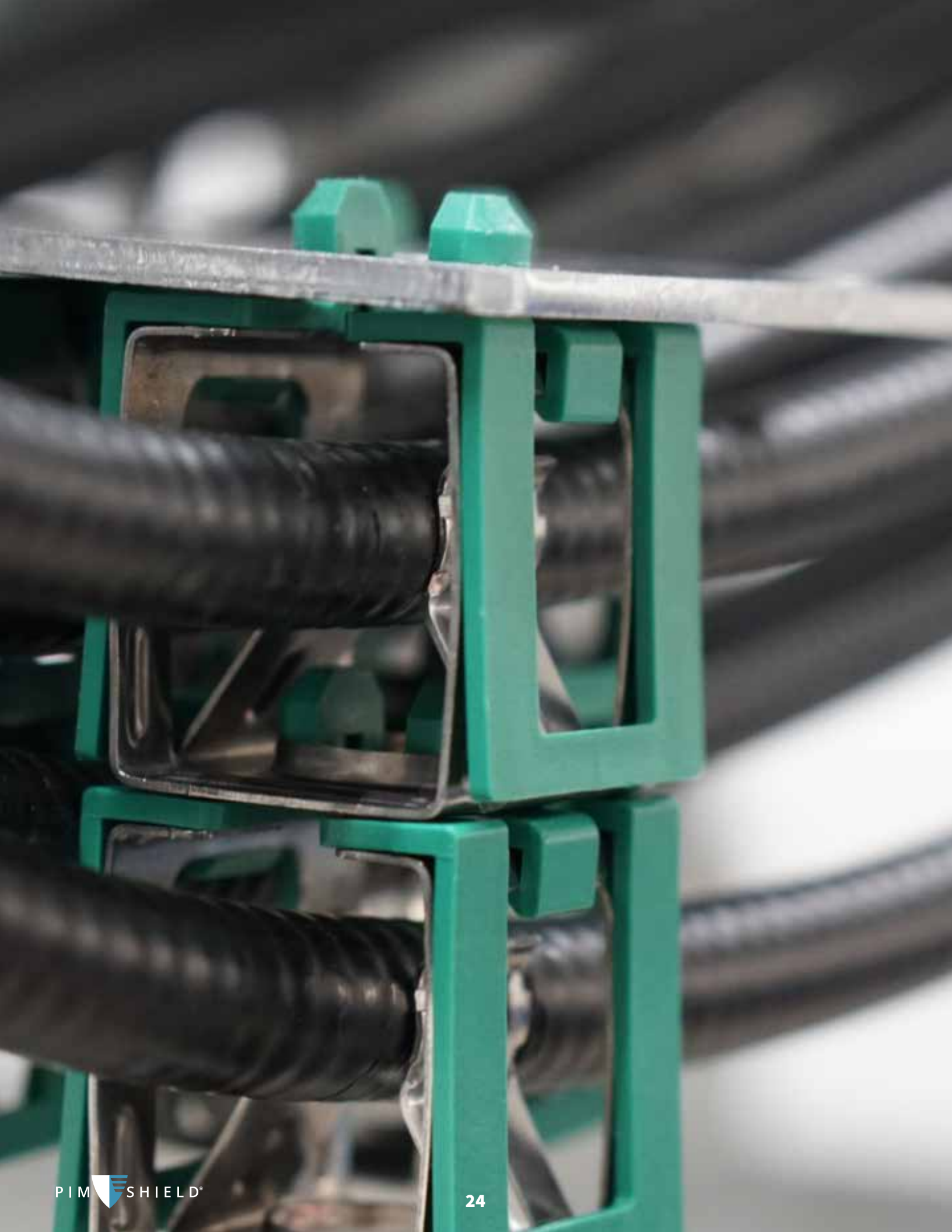



Low PIM Cable Hangers

Low PIM Cable Hangers

LOW PIM CABLE SUPPORT SYSTEMS

ConcealFab has partnered with FIMO, a global leader in cable support systems, to develop a family of low PIM cable support products that can be reliably deployed in the “High-Risk PIM Zone.” Each design has been thoroughly tested in accordance with IEC 62037-8 (Radiated PIM test) to verify low PIM performance.



HYBRID METAL / PLASTIC SNAP-INS

Traditional metal snap-in hangers provide fast assembly but generate high levels of PIM at the contacting surfaces between hangers and at the hanger attachment interface. ConcealFab’s patented “Hybrid” snap-in design provides insulation at the mating interfaces to prevent metal-to-metal contact. “Hybrid” snap-ins deliver low PIM performance along with the strength and installation ease of FIMO’s patented snap-in design.

Key Features

- High strength
- Low PIM
- Easy to install / remove / reposition
- No tools required
- 360° rotation at mounting interface

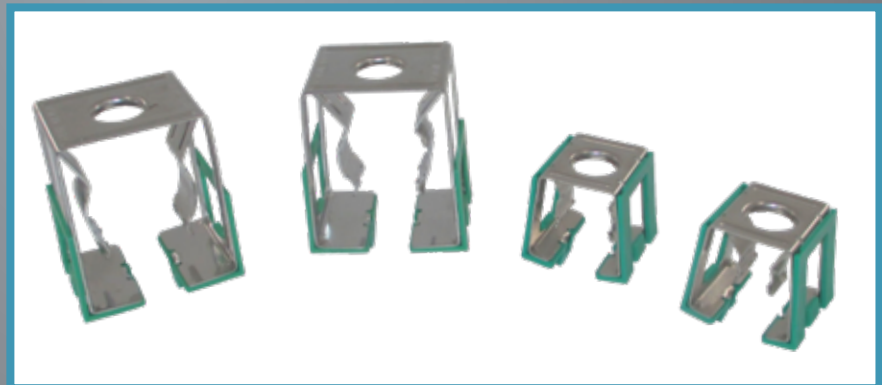

Part Number	Description	Cable Diameter (mm)	Height	Length	Width
PSHS-1319-10	PIM Shield Hybrid Snap-In, 13 to 19 mm (1/2 in)	13 to 19	40 mm (1.57 in)	40 mm (1.57 in)	36 mm (1.42 in)
PSHS-2630-10	PIM Shield Hybrid Snap-In, 26 to 30 mm (7/8 in)	26 to 30	40 mm (1.57 in)	40 mm (1.57 in)	36 mm (1.42 in)
PSHS-3642-10	PIM Shield Hybrid Snap-In, 36 to 42 mm (1-1/4 in)	36 to 42	75.3 mm (2.96 in)	45 mm (1.77 in)	62 mm (2.44 in)
PSHS-4852-10	PIM Shield Hybrid Snap-In, 48 to 52 mm (1-5/8 in)	48 to 52	75.3 mm (2.96 in)	45 mm (1.77 in)	62 mm (2.44 in)

Sold in bags of 10

CABLE CUSHIONS

Cable Cushions that fit inside ConcealFab’s “Hybrid” snap-ins are available to support smaller diameter RET, DC power, grounding and fiber optic cables. Cable Cushions are color-coded for easy identification and inspection.

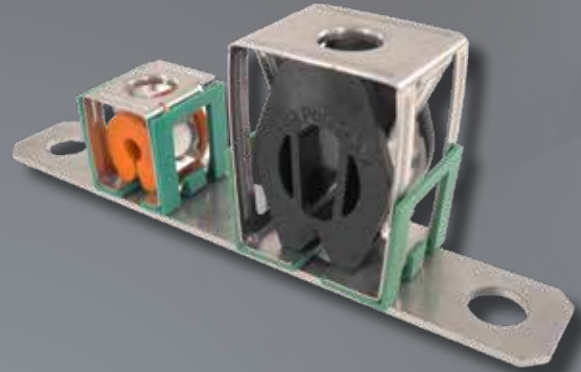

Part Number	Description	Cable Diameter (mm)	Install inside Hybrid Snap-In	Color
PSCC-1001-10	PIM Shield Cable Cushion, 4.5 to 6.5 mm	4.5 - 6.5	PSHS-1319-10	Blue
PSCC-1002-10	PIM Shield Cable Cushion, 6.6 to 8.5 mm	6.6 - 8.5	PSHS-1319-10	Gray
PSCC-1003-10	PIM Shield Cable Cushion, 8.6 to 10.5 mm	8.6 - 10.5	PSHS-1319-10	Black
PSCC-2001-10	PIM Shield Cable Cushion, 10.6 to 12.5 mm	10.6 - 12.5	PSHS-2630-10	Orange
PSCC-2002-10	PIM Shield Cable Cushion, 12.6 to 15.5 mm	12.6 - 15.5	PSHS-2630-10	Black
PSCC-2003-10	PIM Shield Cable Cushion, 15.6 to 17.5 mm	15.6 - 17.5	PSHS-2630-10	Gray
PSCC-4001-10	PIM Shield Cable Cushion, 19.6 to 30.3 mm	19.6 - 30.3	PSHS-4852-10	Black

Sold in bags of 10



Low PIM Cable Hangers

PLASTIC SNAP-INS

PIM Shield® Plastic Snap-ins provide a low passive intermodulation method to secure RF, fiber, power and RET cables in high risk PIM zones. Four all-plastic designs provide inherently PIM-free support for cables ranging from 4mm to 17mm in diameter.

Key Features

- UV stable, glass filled nylon
- Low PIM
- Easy to install / remove / reposition
- No tools required
- 360° rotation at mounting interface

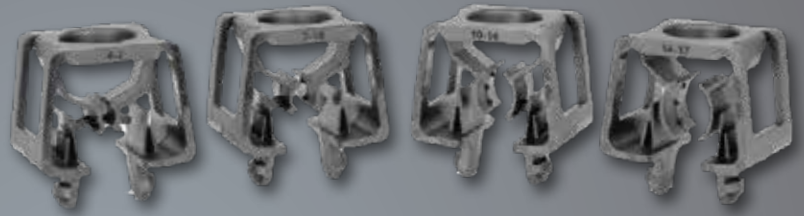

Part Number	Description	Cable Diameter (mm)	Height	Length	Width
PSPS-0407-10	PIM Shield Plastic Snap-In, 4 to 7 mm	4 to 7	31 mm (1.22 in)	30 mm (1.18 in)	36 mm (1.42 in)
PSPS-0710-10	PIM Shield Plastic Snap-In, 7 to 10 mm	7 to 10	31 mm (1.22 in)	30 mm (1.18 in)	36 mm (1.42 in)
PSPS-1014-10	PIM Shield Plastic Snap-In, 10 to 14 mm	10 to 14	31 mm (1.22 in)	30 mm (1.18 in)	36 mm (1.42 in)
PSPS-1417-10	PIM Shield Plastic Snap-In, 14 to 17 mm (1/2 in)	14 to 17	31 mm (1.22 in)	30 mm (1.18 in)	36 mm (1.42 in)

Sold in bags of 10



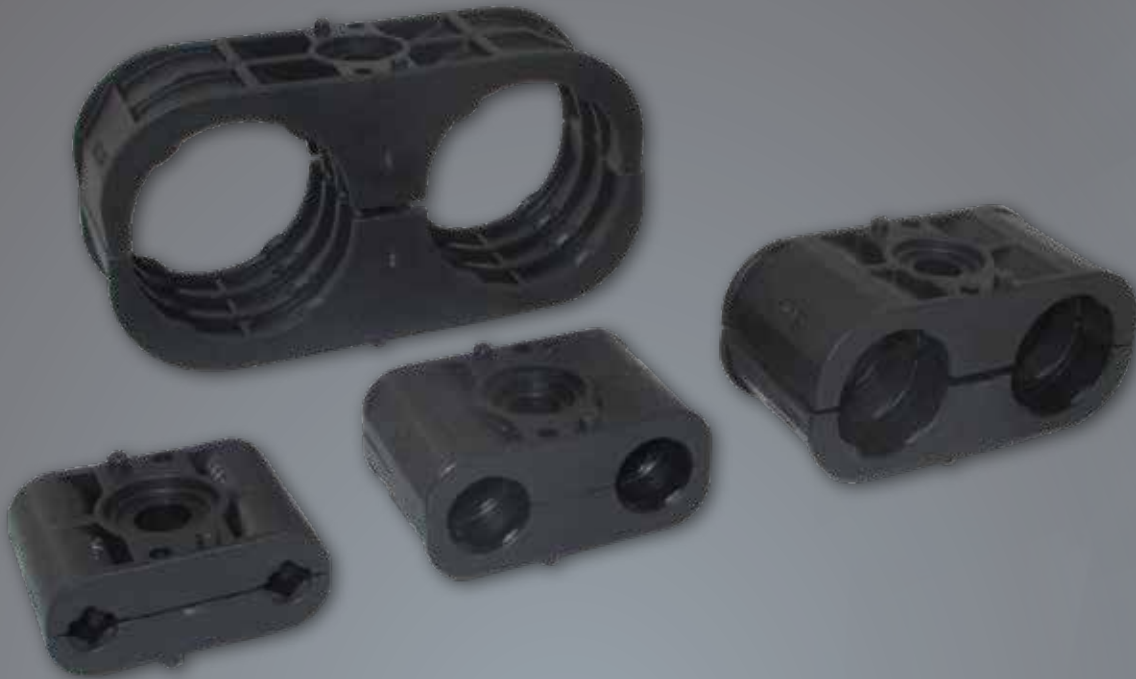

CABLE SUPPORT BLOCKS

When supported and installed correctly, Cable Support Blocks provide a reliable, low PIM method for securing cables at cell sites. ConcealFab offers high strength, UV stable Cable Support Blocks that securely grip two cables without deforming the outer RF conductor. Cable Support Blocks are often selected for high wind zones due to their superior strength and rigid support.



Part Number	Description	Cable Diameter (mm)	Height	Length
PSCB-0405-10	PIM Shield Cable Block, 4.5 to 5.5 mm	4.5 – 5.5	16 mm (0.63 in)	42 mm (1.65 in)
PSCB-0608-10	PIM Shield Cable Block, 6 to 8 mm	6.0 – 8.0	20 mm (0.79 in)	51 mm (2.01 in)
PSCB-0809-10	PIM Shield Cable Block, 8 to 9 mm	8.0 – 9.0	20 mm (0.79 in)	51 mm (2.01 in)
PSCB-1011-10	PIM Shield Cable Block, 10 to 11 mm	10.0 – 11.0	20 mm (0.79 in)	51 mm (2.01 in)
PSCB-1213-10	PIM Shield Cable Block, 12 to 13 mm	12.0 -13.0	27 mm (1.06 in)	60 mm (2.36 in)
PSCB-1314-10	PIM Shield Cable Block, 13 to 14 mm, (1/2 in Hi-Flex)	13.0 - 14.0	27 mm (1.06 in)	60 mm (2.36 in)
PSCB-1517-10	PIM Shield Cable Block, 15.5 to 17 mm, (1/2 in)	15.5 – 17.0	27 mm (1.06 in)	60 mm (2.36 in)
PSCB-2123-10	PIM Shield Cable Block, 21 to 23 mm, (5/8 in)	21.0 – 23.0	37 mm (1.46 in)	84 mm (3.31 in)
PSCB-2728-10	PIM Shield Cable Block, 27 to 28 mm, (7/8 in)	27.0 – 28.0	37 mm (1.46 in)	84 mm (3.31 in)
PSCB-3940-10	PIM Shield Cable Block, 39 to 40 mm, (1-1/4 in)	39.0 – 40.0	54 mm (2.13 in)	108 mm (4.25 in)
PSCB-5052-10	PIM Shield Cable Block, 50 to 52 mm, (1-5/8 in)	50.0 – 52.0	66 mm (2.60 in)	133 mm (5.24 in)

Sold in bags of 20 halves to make 10 Cable Support Blocks





Threaded Rod Kits

Threaded Rods

PIM Shield® Threaded Rod Kits provide a low PIM mounting system to secure cables in high-risk PIM zones. To prevent galvanic corrosion, galvanized steel threaded rod kits should be used with galvanized support brackets and stainless-steel threaded rod kits should be used with stainless-steel support brackets.

Each Kit Contains:

- 30x 3/8" Threaded rod
- 30x 3/8" Nut
- 30x Lock washer
- 30x Flat washer



STAINLESS-STEEL THREADED ROD KITS

Part Number	Description
900210-10	PIM Shield Threaded Rod Kit, SS, 3/8" x 2-in
900211-10	PIM Shield Threaded Rod Kit, SS, 3/8" x 6-in
900212-10	PIM Shield Threaded Rod Kit, SS, 3/8" x 8-in
900381-10	PIM Shield Threaded Rod Kit, SS, 3/8" x 12-in

Sold in bags of 10

GALVANIZED STEEL THREADED ROD KITS

Part Number	Description
900714-10	PIM Shield Threaded Rod Kit, Galvanized, 3/8" x 6.5-in
900715-10	PIM Shield Threaded Rod Kit, Galvanized, 3/8" x 9-in

Sold in bags of 10



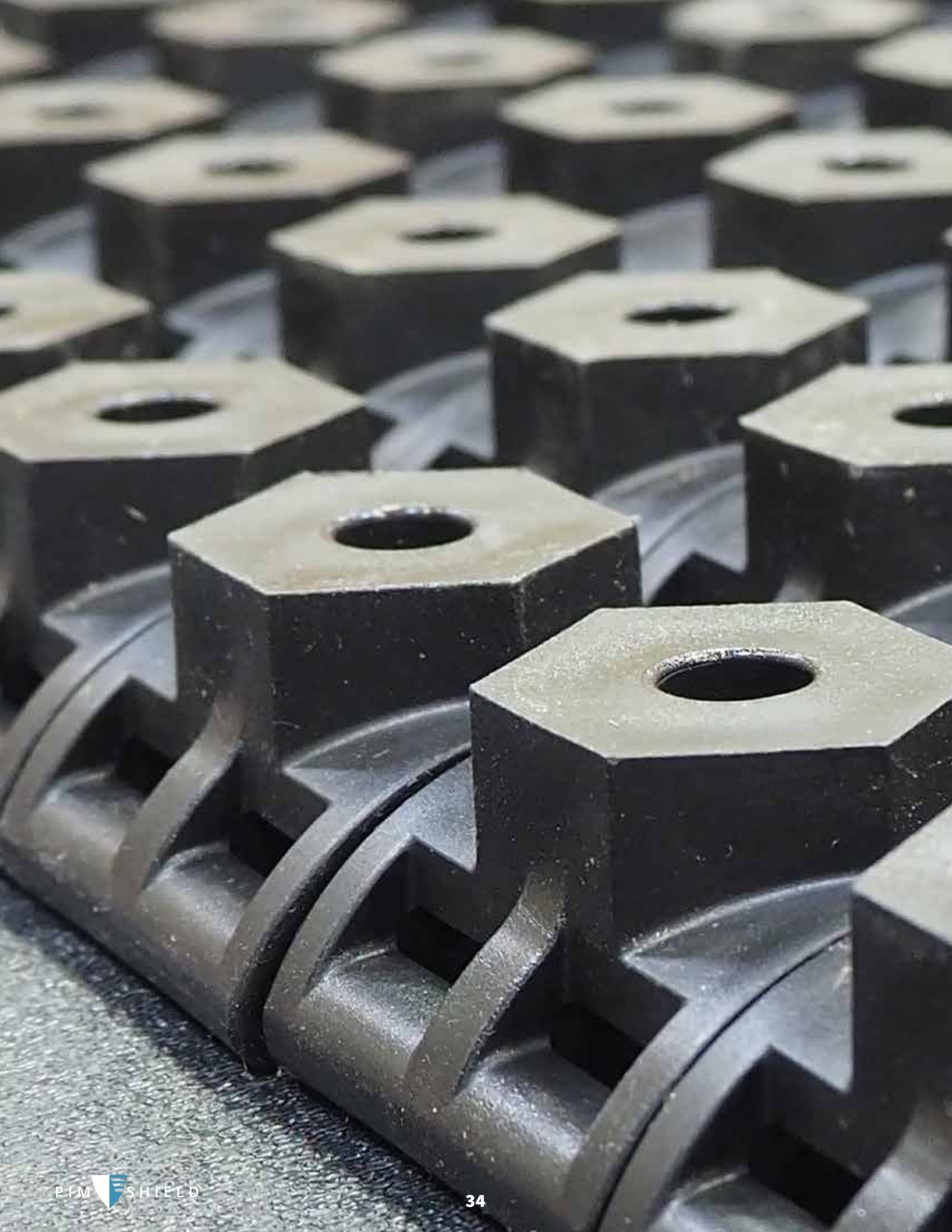

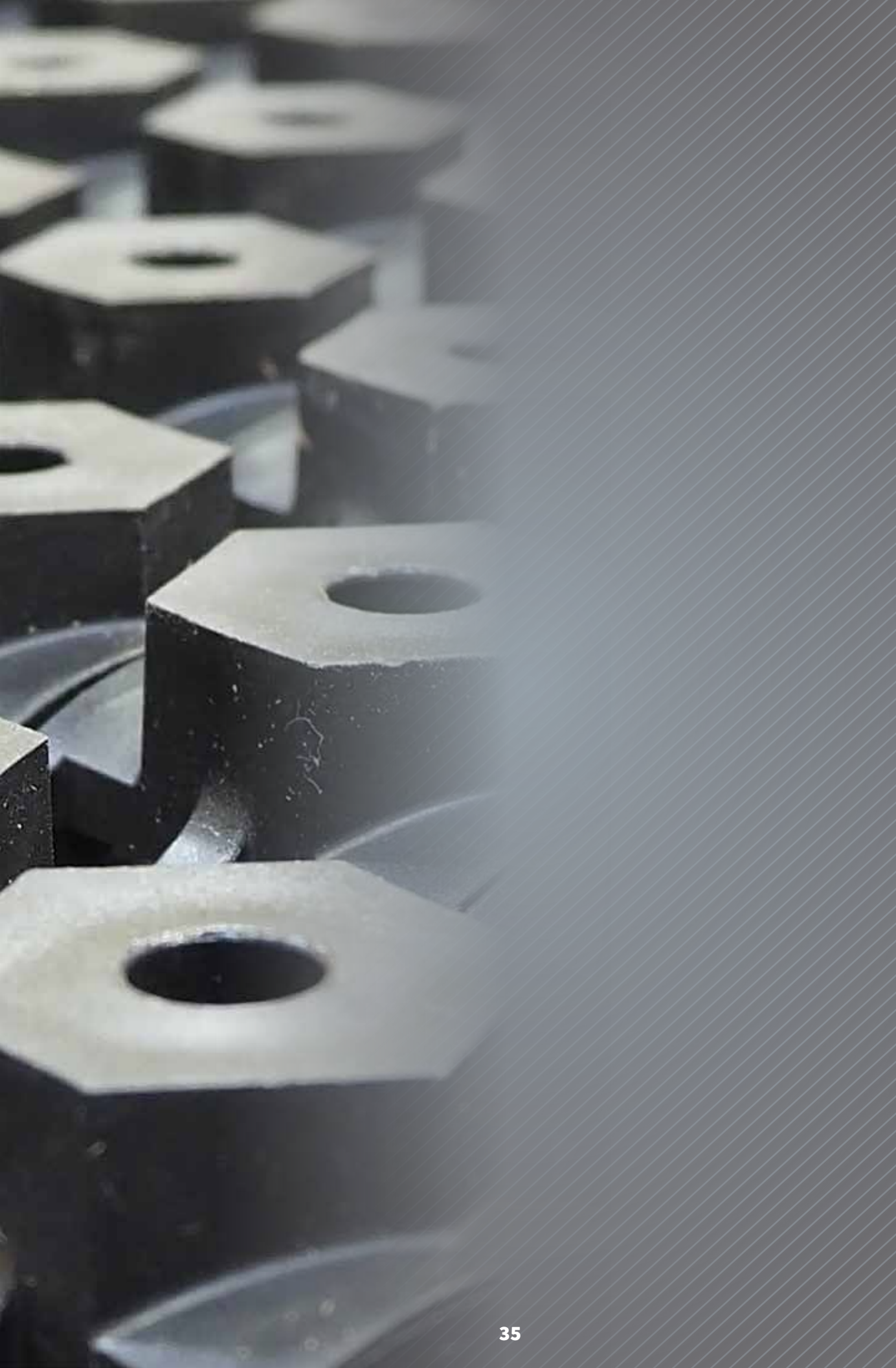

Non-Metallic Supports

Non-Metallic Supports

CABLE STRAPS

ConcealFab's non-metallic cable support straps are a low PIM replacement for hose clamps at cell sites. The straps are designed from high strength, weather resistant Acetal and provide >200 lbs. loop tensile strength at 70°C (158°F) and >400 lbs. loop tensile strength at -40°C (-40°F). Straps are supplied cut to length with the locking head pre-installed.



Part Number	Description	Grip Range
900443-16-50	PIM Shield Cable Strap, Acetal, 1/2 in x 16 in, Qty. 50	Up to 3 Inch Pipe (3.5-Inch OD)
900443-27-25	PIM Shield Cable Strap, Acetal, 1/2 in x 27 in, Qty. 25	Up to 6 Inch Pipe (6.6-Inch OD)

900209-10

Part Number
(3/8" SS inner nut included)



Part Number	Description
900209-10	PIM Shield Cable Support Base with Large Head Nut, SS
900351-10	PIM Shield Cable Support Bar, 4 Position, SS

Sold in bags of 10

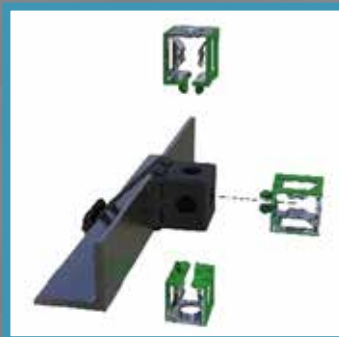

Part Number	Description
900860-10	PIM Shield Snap-in Adapter, Trapezoid, 3 Position
900945-10	PIM Shield Snap-in Adapter, Cube, 5 Position

Sold in bags of 10

CABLE SUPPORT BASE

ConcealFab's patented Cable Support Base provides a low PIM method to secure 3/8-inch stainless-steel threaded hardware to round members at cell sites.



900860-10

Part Number



900945-10

Part Number



SNAP-IN SUPPORTS

ConcealFab's all-plastic snap-in adapters provide low PIM mounting locations for snap-in style cable hangers in high-risk PIM zones. The 5-position adapter is ideally suited for attachment to the flat side of angle members using two PIM Shield® cable support straps.

RF SAFETY SIGN SUPPORTS

Low PIM method to securely mount RF safety signs in high-risk PIM zones. The solution involves drilling or punching two 0.375-inch diameter holes in the sign and attaching two low PIM plastic supports to the sign. Secure using 2x Cable Support Straps.



Part Number	Description
901031-10	PIM Shield RF Safety Sign Support, Qty. 10
901034	PIM Shield RF Safety Sign Support Kit, W/Straps

UNIVERSAL CABLE SUPPORT SYSTEM

ConcealFab's patented Universal Mounting System consists of interchangeable low PIM plastic bases and adapters for securing cables to round or angle shaped members at cell sites using two ConcealFab Cable Straps. The Universal Mounting System supports a wide variety of low PIM cable support scenarios using only five unique parts.

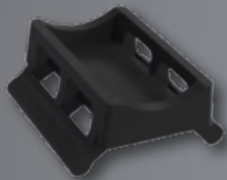

Part Number
900638-10



Part Number
900639-10
(up to 1/4-inch flange)

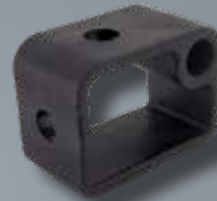

Part Number
900712-10



Part Number
900713-10

Part Number
900940-10
(up to 3/8-inch flange)

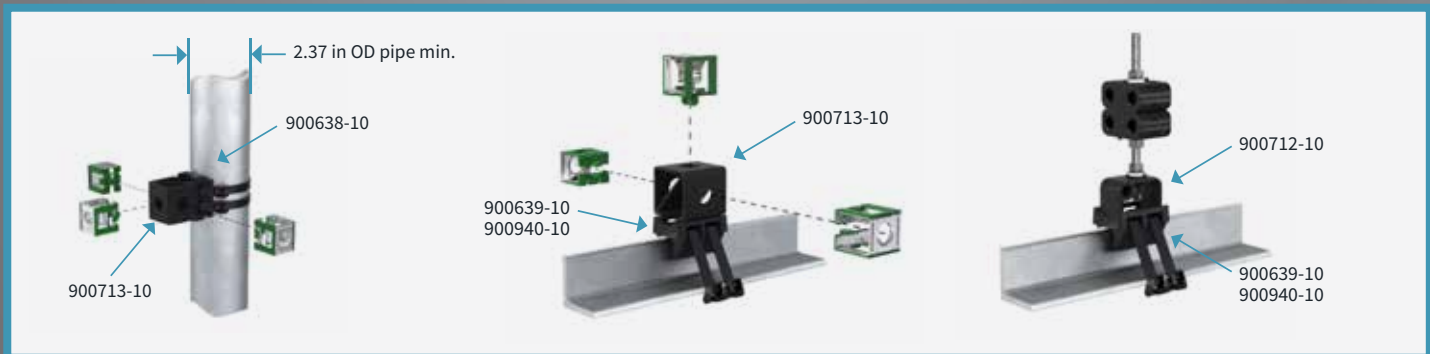

Part Number	Description
900638-10	PIM Shield Universal Base, Round Member Adapter
900639-10	PIM Shield Universal Base, Angle Adapter, 1/4-inch
900940-10	PIM Shield Universal Base, Angle Adapter, 3/8-inch
900712-10	PIM Shield Threaded Rod Adapter Block
900713-10	PIM Shield Snap-in Adapter Block, 3 Position

Sold in bags of 10

Non-Metallic Supports

MULTI-FUNCTION CABLE SUPPORT SYSTEM

ConcealFab's Multi-Function Cable Support system provides a low cost, low PIM method to secure cables to round or angle members at cell sites. These unique, patent pending designs include molded-in features for secure attachment to pipes or angle member flanges, eliminating the need for multiple parts.

1X THREADED ROD LAUNCH

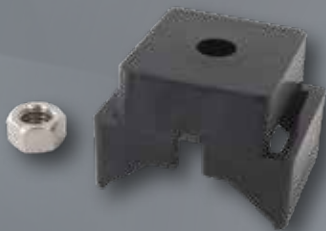

Part Number

901043-10

(3/8" SS inner nut included)

1X SNAP-IN LAUNCH

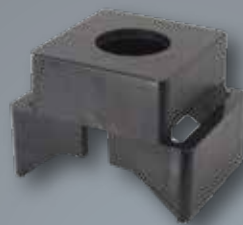

Part Number

901044-10

2X SNAP-IN LAUNCH 1X THREADED ROD LAUNCH



Part Number

901045-10

(3/8" inner nut not included)

Molded-in features provide secure attachment to round or angle members.

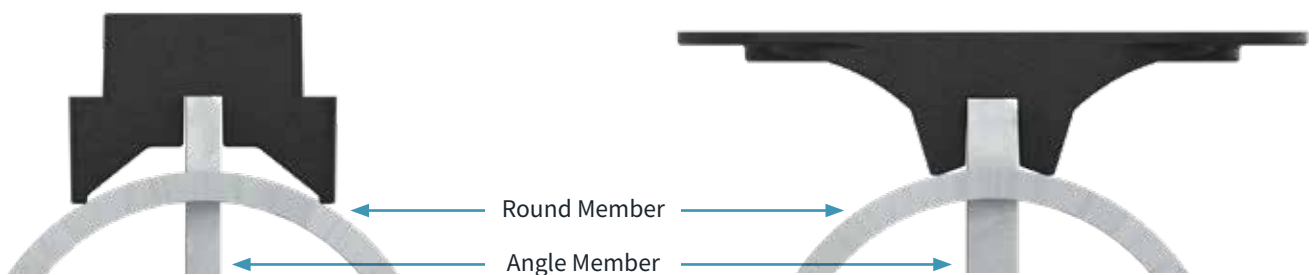

Part Number	Description
901043-10	PIM Shield Multi-Function Cable Support Base, SS
901044-10	PIM Shield Multi-Function Snap-in Adapter, 1 Position
901045-10	PIM Shield Multi-Function Snap-in Adapter, 2 Position

Sold in bags of 10

MULTI-FUNCTION CABLE SUPPORT SYSTEM



Part Number
901043-10



Part Number
901044-10



Part Number
901045-10

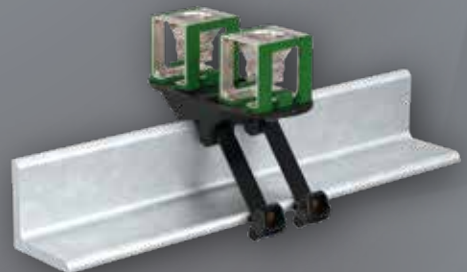





Metallic Supports

Metallic Supports

SUPPORT BRACKETS

ConcealFab offers heavy duty galvanized steel support brackets for securing Cable Support Blocks to antenna mounting pipes. The kit includes galvanized threaded rods and galvanized hardware to eliminate all dissimilar metal contacts. Kits are available with different threaded rod lengths based on the grip range desired.

Key Features

- Low PIM
- Galvanized steel construction
- Supports up to 12 cables

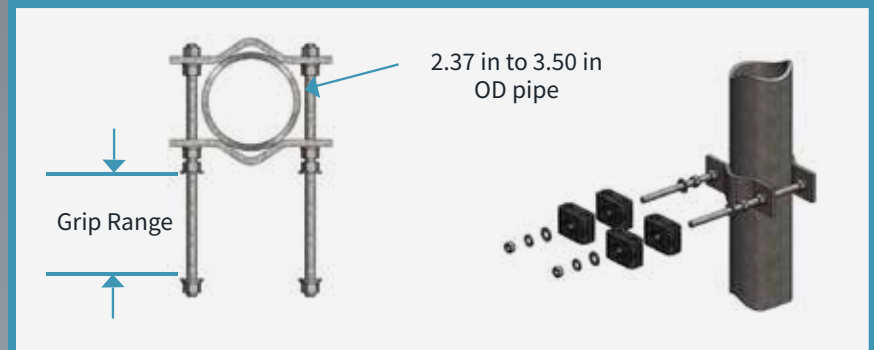

Brackets sold in kits of 10, Torque wrenches sold individually

Part Number	Description	Grip Range
009718-01-10	PIM Shield Cable Support Bracket, Small	32 mm (1.25 in)
009718-02-10	PIM Shield Cable Support Bracket, Large	95 mm (3.75 in)

Sold in bags of 10

HIGH CABLE COUNT SNAP-IN MOUNTING SYSTEM

ConcealFab offers simple, highly configurable mounting systems for securing large quantities of cables to round structural members at a cell site. The all galvanized steel construction with high clamping force provides consistent low PIM performance. Two different threaded rod lengths are available for placing support bars at varying distances from the pipe. Extra bar kits can be purchased and installed as needed.

Key Features

- Low PIM
- Highly configurable
- Galvanized steel construction
- Up to 22 “Hybrid” snap-in support points

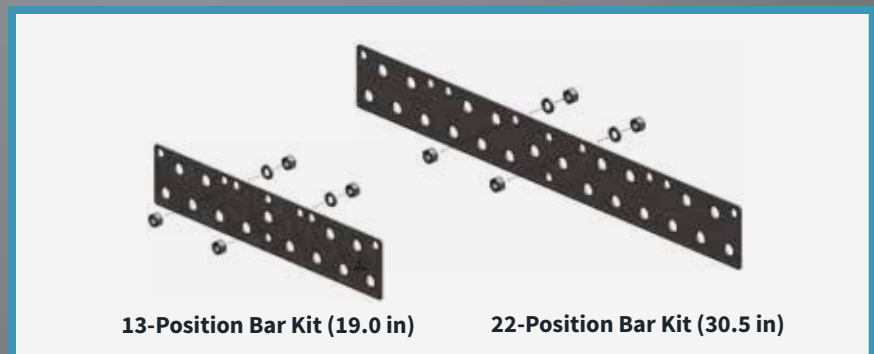

Part Number	Description
900354	PIM Shield Cable Support, Extra Bar Kit, 13-Position
900355	PIM Shield Cable Support, Extra Bar Kit, 22-Position

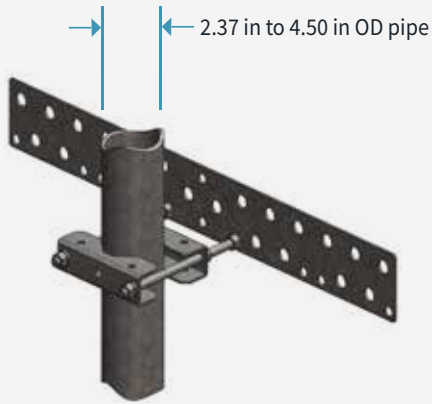

22-Position Pole Mount Kit

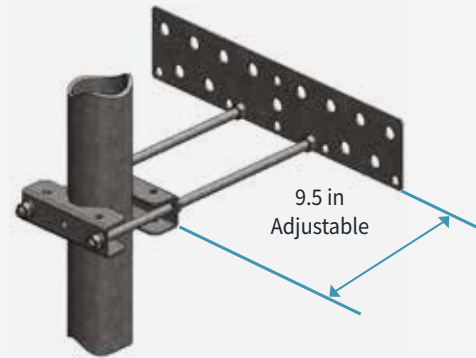

13-Position Extended Range Pole Mount Kit

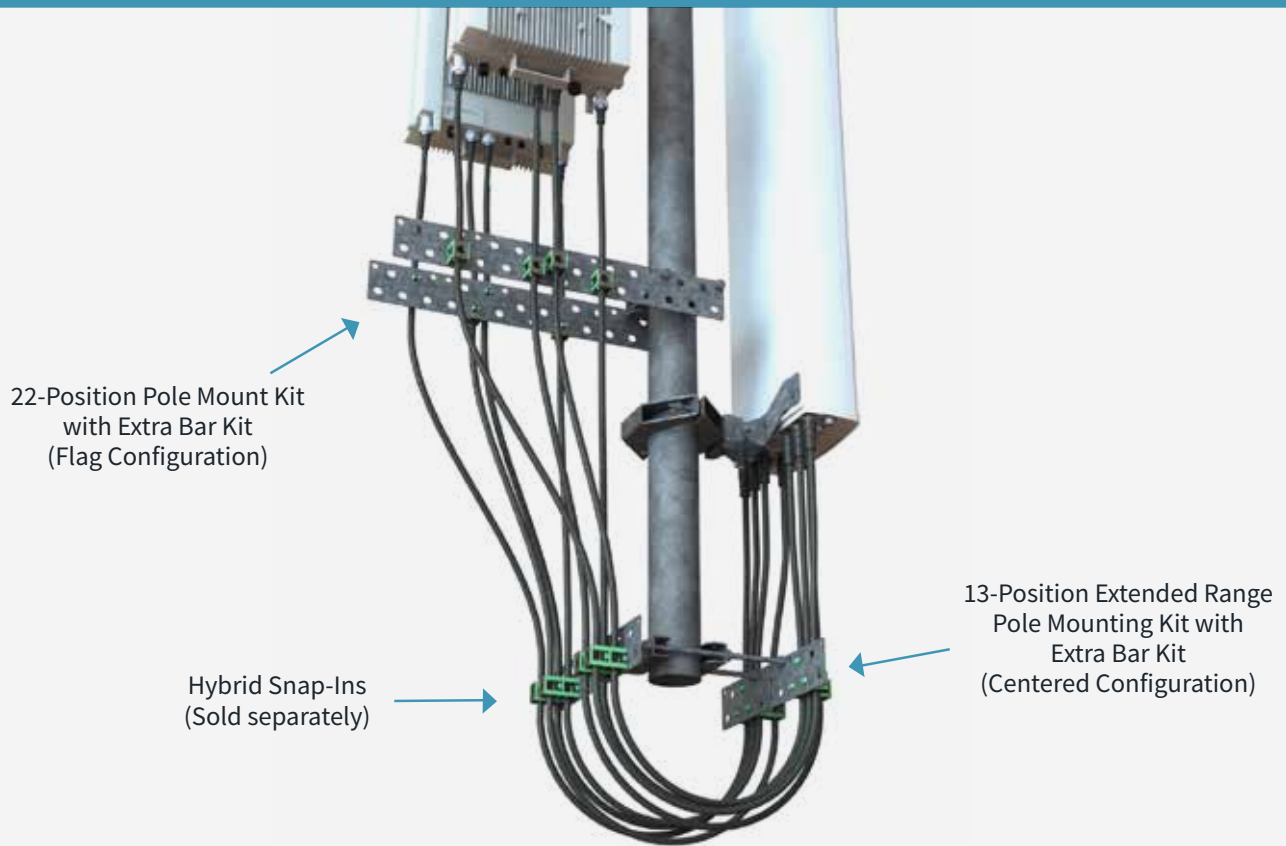

Part Number	Description
900352-01	PIM Shield Cable Support Bar, Pole Mount Kit, 13-Position
900352-02	PIM Shield Cable Support Bar, Pole Mount Kit, 13-Position, Extended Range
900353-01	PIM Shield Cable Support Bar, Pole Mount kit, 22-Position
900353-02	PIM Shield Cable Support Bar, Pole Mount kit, 22-Position, Extended Range





Rail System

Rail System

PIM SHIELD® RAIL SYSTEM

Steel strut has been used for many years around cell sites to secure mechanical equipment and to secure large quantities of RF cables. While the strut itself is not usually a source of passive intermodulation (PIM), attachments to the strut often do create PIM.

ConcealFab studied this problem and developed its patented PIM Shield® Rail System as a low PIM alternative for traditional steel strut. The system includes a custom H-shaped aluminum rail along with injection molded Channel Runners to insulate mounting hardware from touching the rail.



CHANNEL RUNNER KITS

Channel Runner Kits include injection molded insulators (pre-assembled) with either stainless-steel or galvanized steel fastening hardware. Channel Runner kits are sold with either a nut (for attaching threaded rods to the rail) or with a bolt (for attaching the rail to support structures.)

Channel Runner Kits

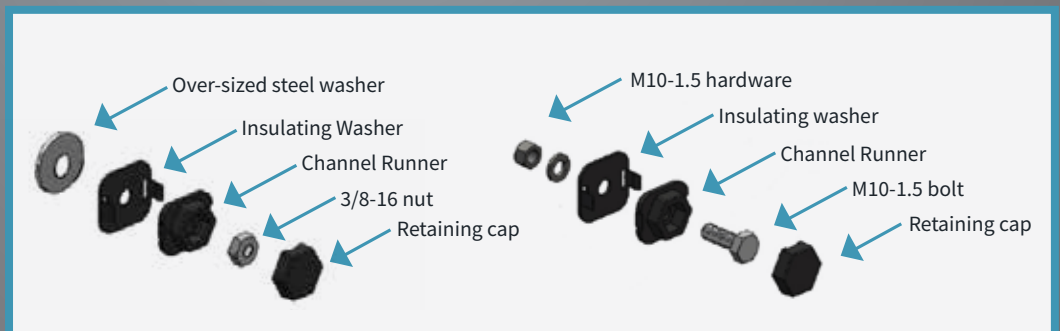

Part Number	Hardware
900362-10	3/8-16 Nut, SS
900711-10	3/8-16 Nut, Galvanized

Sold in kits of 10

Part Number	Hardware
900589-10	M10-1.5 Bolt, SS
900360-10	M10-1.5 Bolt, Galvanized

Sold in kits of 10

POLE MOUNTING KITS

Complete Pole Mounting Kits that include a galvanized steel pipe grip are available plus either a 12-inch or 24-inch aluminum rail kit. Pole mounting kits can be installed below antennas or radios to provide a base for supporting large numbers of RF, RET, power and fiber cables.



Part Number	Description
900356	PIM Shield Cable Support Rail, Pole Mount Kit, 12 Inch
900357	PIM Shield Cable Support Rail, Pole Mount Kit, 24 Inch

Front side channel runner kits and threaded rod kits sold separately

EXTRA RAIL KITS

Extra Rail Kits include one 12-inch or 24-inch aluminum rail and two Channel Runners in one convenient kit. Bolt-style Extra Rail Kits can be added to Pole Mounting Kits to provide a second rail on the back side of the mount or can be deployed with ConcealFab's Wall Mounting Brackets to support cables on vertical or horizontal surfaces. Nut-style Extra Rail Kits are typically used with ConcealFab's Pole Mounting Brackets (009718-01-10 or 009718-02-10) when space is limited behind the pipe.

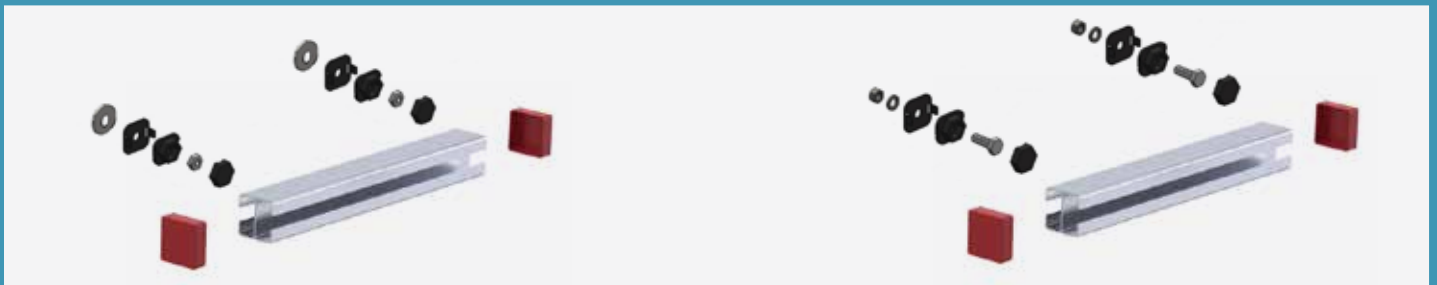

Part Number	Rail Length	Channel Runners
900731-12	12-Inch	3/8-16 Nut, Galvanized
900731-24	24-Inch	3/8-16 Nut, Galvanized

Part Number	Rail Length	Channel Runners
900359-12	12-Inch	M10-1.5 Bolt, Galvanized
900359-24	24-Inch	M10-1.5 Bolt, Galvanized

(Threaded Rod Kits and Cable Support Blocks sold separately)



900731-xx Extra Rail Kit with 009718-xx-10 mounting bracket



900359-xx Extra Rail Kit with 900361 wall mounting bracket kit

Rail System

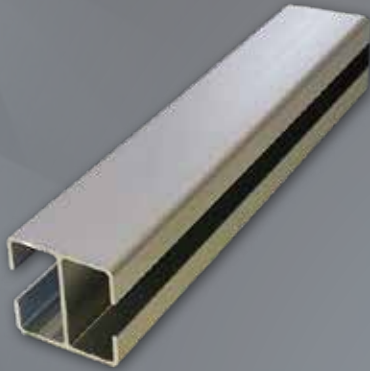

RAIL MATERIAL

PIM Shield® Rail Material is a custom extruded 6005-T61 aluminum profile with a clear anodized finish. The Rail Material is available by itself in 6-FT lengths (10 sticks to a case.) The Rail Material can also be field cut to the desired length for custom installations.

Part Number	Description
900363-6	PIM Shield Cable Support Rail, 6 FT (no hardware)

POLE MOUNTING BRACKETS

Galvanized steel Pole Mounting Brackets are available for attaching Rail Material to 2.37-inch to 4.5-inch OD round members. This kit provides two sets of mounting tabs for attaching Rail Material (sold separately) on either side of a pipe.



Part Number	Description
900358	PIM Shield Saddle Bracket with Tabs, Galvanized

WALL MOUNTING BRACKETS

Galvanized steel Wall Mounting Brackets are available for attaching Rail Material to horizontal or vertical surfaces. Each kit includes two formed galvanized steel brackets.

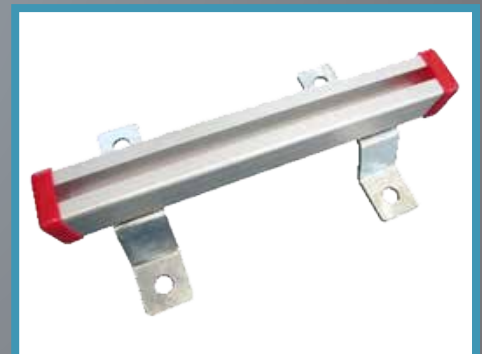

Part Number	Description
900361	PIM Shield Cable Support Rail, Wall Mount Brackets, Galvanized



CROSS KIT

Cross Kits are available for securely attaching one rail to two support rails at 90° orientation. Each Cross kit includes two stainless-steel cross-over plates and eight 900589-10 stainless-steel Channel Runners.

Part Number	Description
900588	PIM Shield Rail, Cross Kit, SS

EXAMPLE ASSEMBLY: EQUIPMENT SUPPORT FRAME

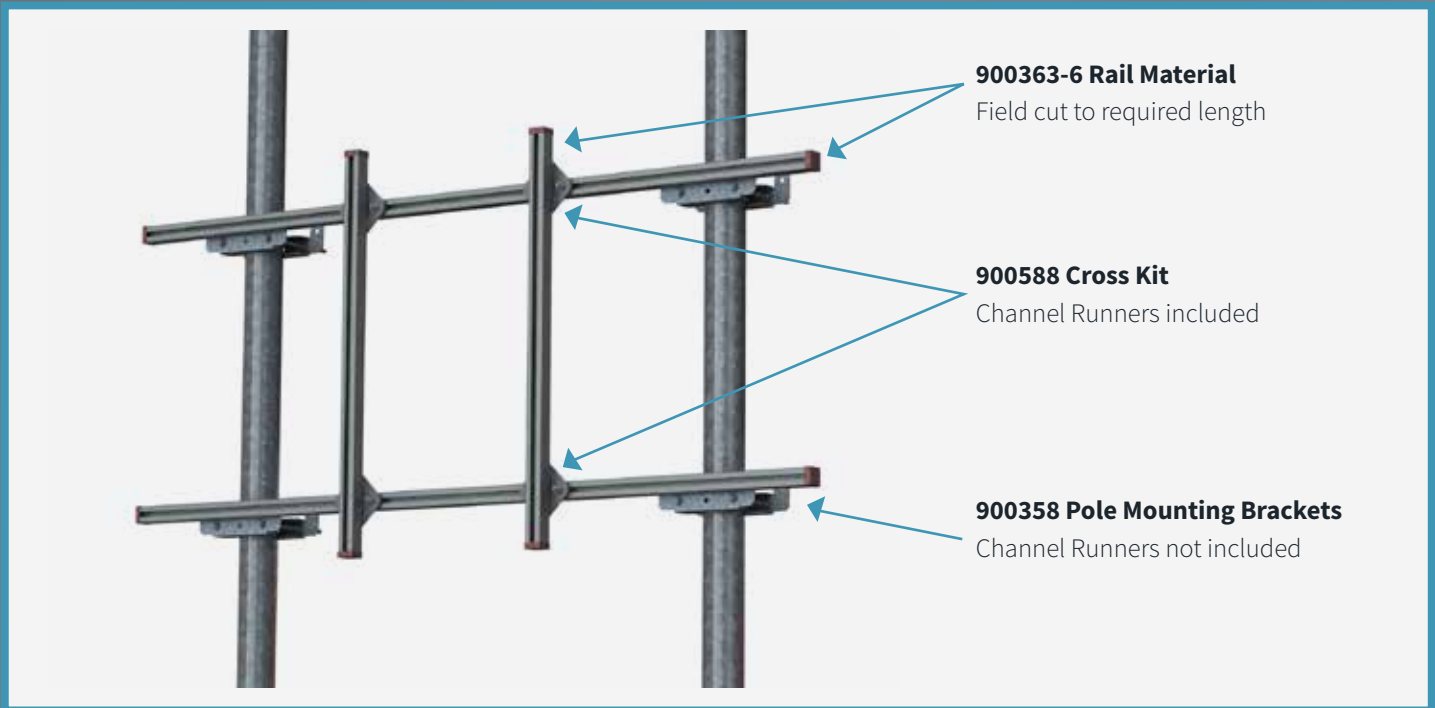

EXAMPLE ASSEMBLY: CABLE SUPPORT







Installation Tools

Installation Tools

TORQUE WRENCHES

Proper installation torque is required for any bolted connection to achieve low PIM performance. Too much torque can result in bracket deformation and too little torque can result in loose metal-to-metal contact. ConcealFab has determined the optimum torque for each of its PIM Shield® Cable Support Systems and offers convenient, fixed torque wrenches for each torque requirement.



900053
Part Number

Part Number	Head Size	Torque	Use with	Grip Color
901039	9/16-inch	4 FT-LB	3/8-Inch Hardware	Red
900053	9/16-inch	10 FT-LB	3/8-Inch Hardware	Blue
900412	17-mm	15 FT-LB	M10 Hardware	Blue
900413	3/4-inch	20 FT-LB	1/2-Inch Hardware	Blue

Each kit contains 10 sets of the hardware shown

CABLE STRAP INSTALLATION TOOLS

Optimized for the ConcealFab Cable Straps, the installation tool tightens and cuts the strap at the maximum grip point. Unlike other tools that can slip on the straps, this installation tool incorporates a more aggressive grip surface to achieve maximum friction while tensioning.



900442
Part Number



Aggressive Strap
Gripping Surface

Removeable
Cutting Head





Backlobe Suppressors



Backlobe Suppressors

Engineers designing a cellular system use directional base station antennas to focus energy into the desired area of coverage. An ideal base station antenna would only radiate energy where intended and radiate no energy in unwanted directions. Unfortunately, that is not possible (or practical) given the size and cost constraints placed on base station antenna manufacturers. Unwanted side and backlobe radiation often occurs at lower frequencies where the physical size of the antenna is small with respect to a wavelength.

To combat undesired backlobe radiation, ConcealFab has developed surface wave suppression technology that can be applied to existing base station panel antennas. The suppressors are built onto an aluminum frame and coated with polyurethane (truck bed liner) for environmental protection. Hardware is provided to attach the suppressor between the antenna and its existing pole mounting hardware. Due to size and physical mounting differences, a unique backlobe suppressor design is required for each different antenna model.

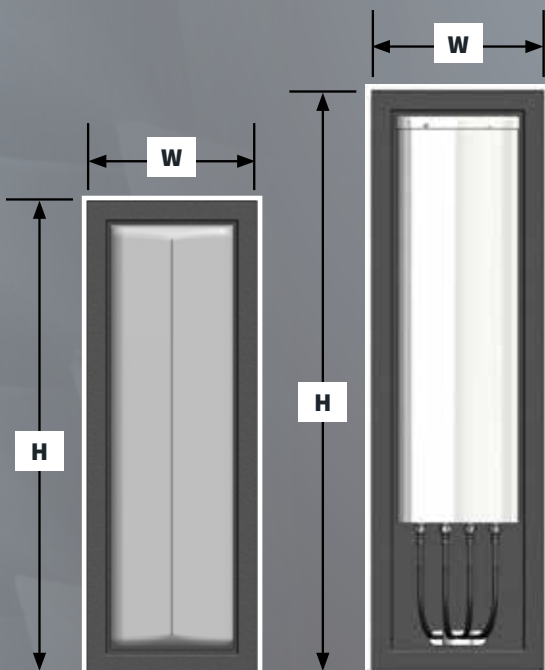

*The dimensions shown are for planning purposes only.
Final design dimensions may vary.*

DIMENSION "W"
Antenna Width + 5.50-inch

RF CONNECTOR DIRECTION	JUMPER CABLE TYPE	DIMENSION "H"
Rear	Any	Antenna Height + 5.50-inch
Bottom	Superflex	Antenna Height + 10.75-inch
Bottom	Standard	Antenna Height + 14.75-inch

While results will vary from antenna model to antenna model and from frequency to frequency, the plots below are representative of the performance improvements typically achieved. The blue plots represent the far field, co-polarized radiation patterns and the red plots represent the far field, cross-polarized radiation patterns. Here, the front-to-back ratio, measured within the 30° cone behind the antenna improved from 16 dB to 28 dB with the BackLobe Suppressor installed.

As is typical with most $\pm 45^\circ$ polarized antennas, cross-pol radiation in the lower frequency bands is often higher than the level indicated in the planning tool patterns. This is not due to antenna manufacturers trying to hide information. Rather, it is due to the accepted industry standard that planning tool patterns are derived from co-polarized radiation patterns rather than total energy radiation patterns. While co-pol patterns may be perfectly adequate for predicting performance at typical macro sectors, they may not adequately predict performance at tightly spaced stadium sectors. ConcealFab's Backlobe Suppressors provide an effective way to clean-up unwanted backlobe radiation when predicted performance does not match actual performance.

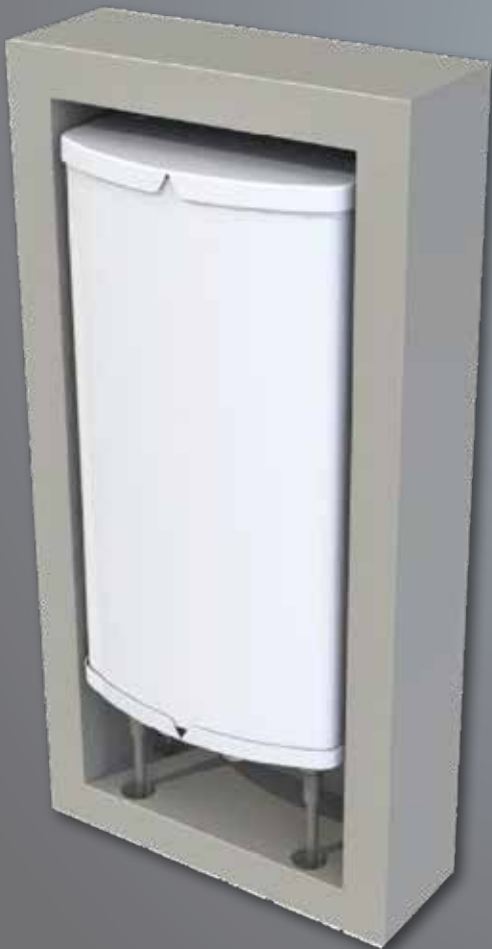

698 MHz - Without Backlobe Suppressor

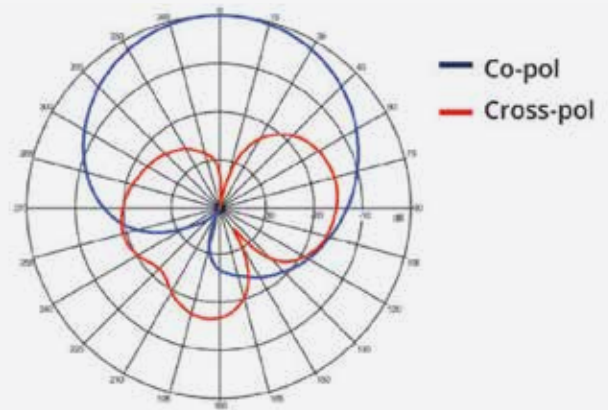

698 MHz - With Backlobe Suppressor

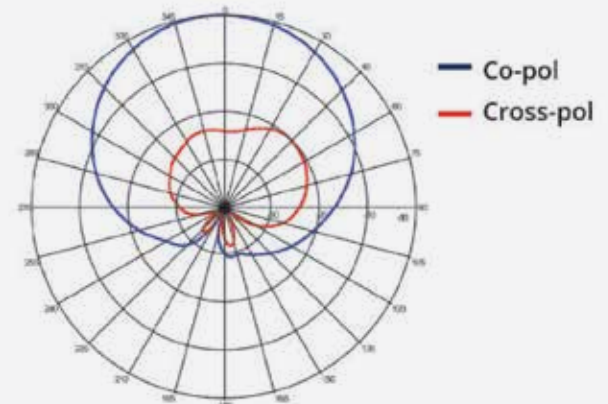



Precision Marketing represents ConcealFab in the states indicated. Their knowledge of RF products and our products specifically, coupled with their carrier and non-carrier relationships creates a powerful local support team for ConcealFab. For international inquiries and inquiries outside of Precision Marketing’s area of representation, please contact ConcealFab directly.

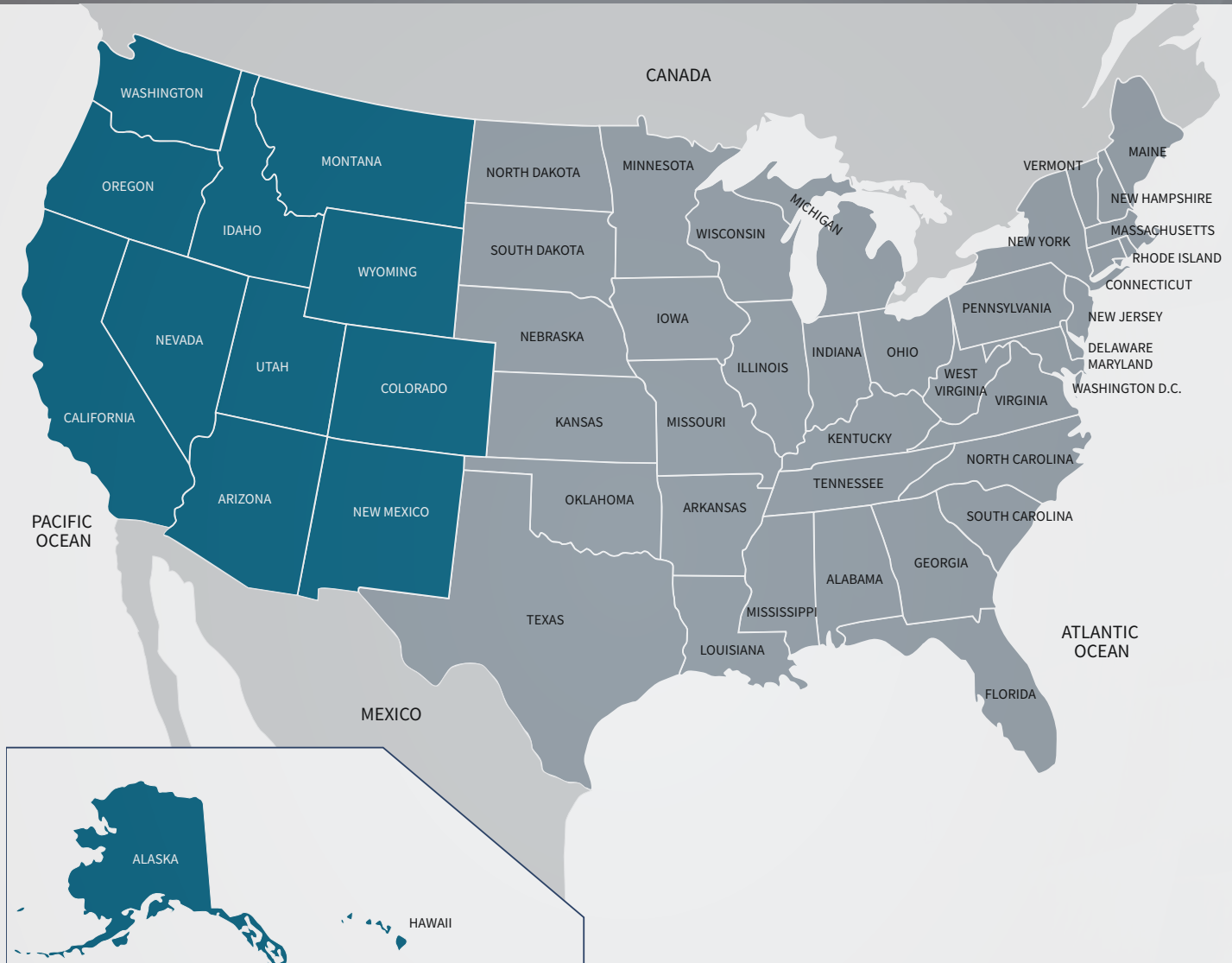

Sales Contacts

ConcealFab Corporation
 AK, AZ, CA, CO, HI, ID, MT, NM, NV, OR, UT,
 WA, WY, International Inquiries

ConcealFab Corporation Contact:
sales@concealfab.com
 +1 719 599 3400

Precision Marketing Inc.
 AL, AR, CT, FL, DC, DE, GA, IA, IL, IN, KY, KS, LA, MA, MI,
 MD, ME, MN, MO, MS, NH, ND, NE, NJ, NC, NY, OH, OK,
 PA, SC, SD, TN, TX, RI, VA, VT, WI, WV

Precision Marketing Contact:
sales@precision-marketing.com
 +1 954 752 1700



+ 1 719 599 3400
sales@concealfab.com
www.concealfab.com

10205 Federal Drive, Building B.
Colorado Springs, CO 80908



*Request a quote from
sales@concealfab.com*

