

EMC Dual-Ridge Horn

EH1840 (18 – 40 GHz)



SOLUTION FOR

Radiated emissions testing according to

- FCC
- MIL-STD-461
- SAE ARP 958

Main features

Technical performance

- Single linear polarization
- Smooth / balanced gain with frequency
- Low return loss / VSWR

Design

- Unique design preventing the excitation of unwanted high order modes in the aperture
- Well defined smooth radiation pattern throughout the operational bandwidth
- Stiff / robust and lightweight mechanical design
- Precision machined
- High reliability 2.92 mm coaxial connector

Product configuration

Equipment

- Storage box
- Standard axial mounting interface
- Custom mounting interface
- Antenna tripod

Services

- Calibration
- Maintenance

Delivered documents

- Technical description document
- Calibration certificate

Included Optional

Far-field radiation pattern

— E-plane — H-plane

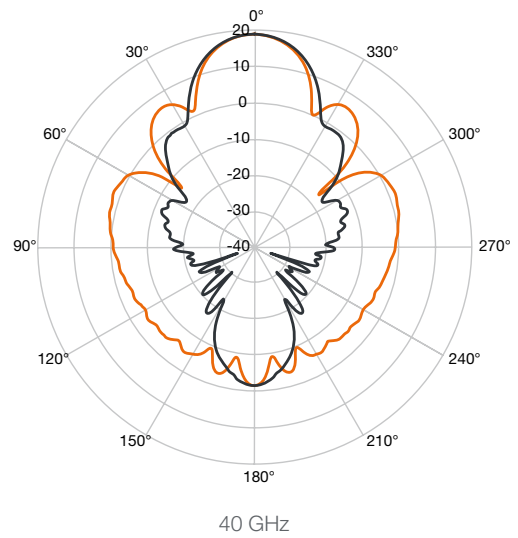
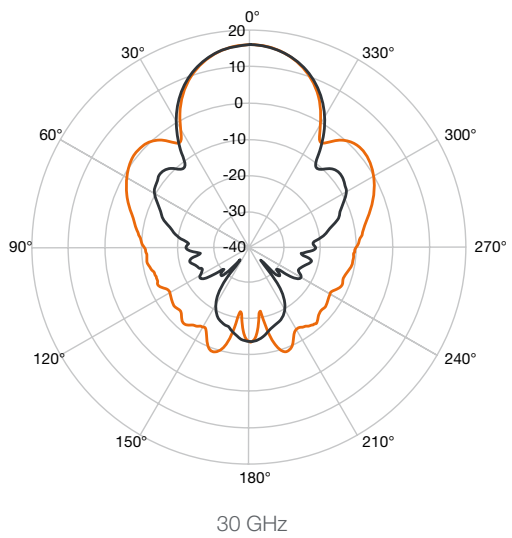
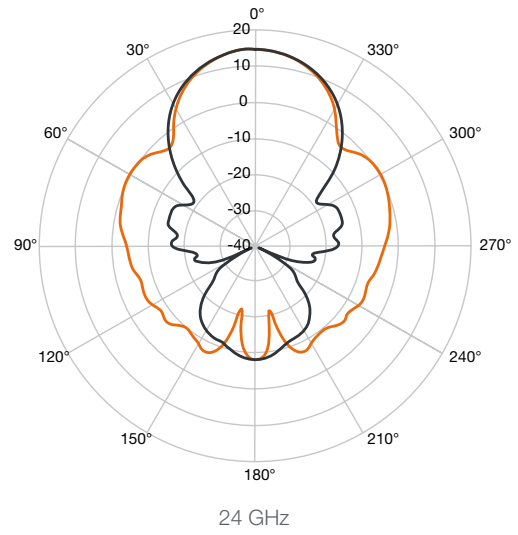
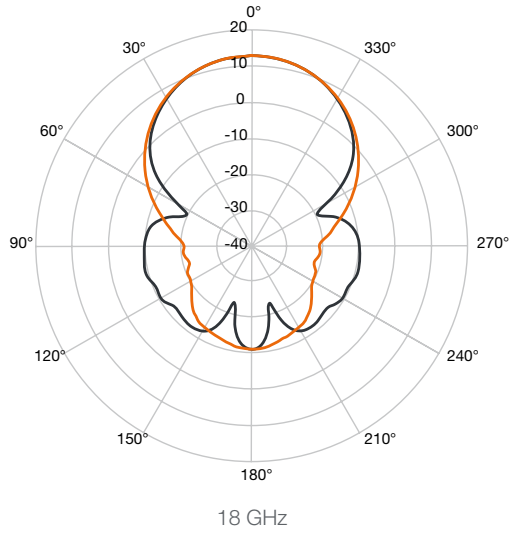

Gain / Antenna factor

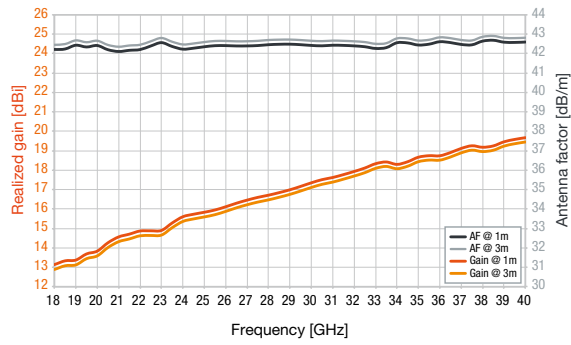

VSWR

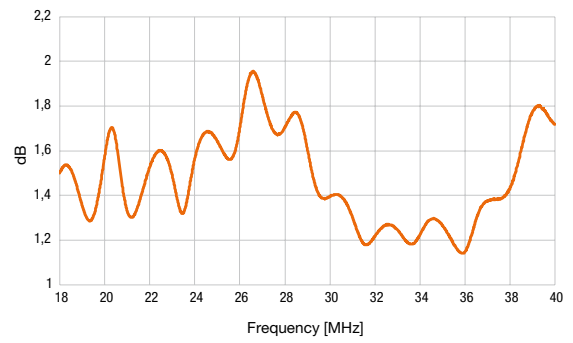

-3 dB beamwidth

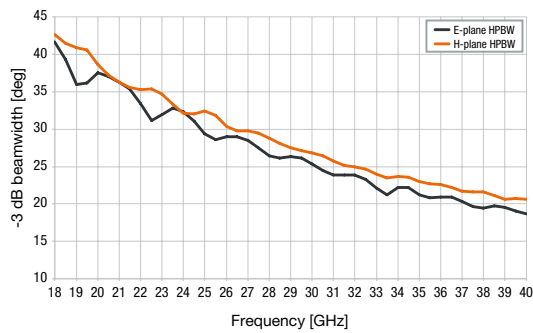

Power handling (CW) / Forward power

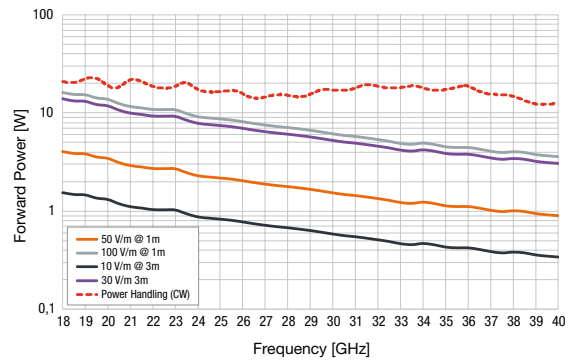

Electrical characteristics

Type of antenna	EMC Dual-Ridge Horn
Frequency range	18 – 40 GHz
Realized gain	13 – 19 dBi
Antenna factor	42 – 43 dB/m
E-plane HPBW (2x)	18 – 42 deg
H-plane HPBW (2x)	20 – 41 deg
VSWR	1.1 to 1.9 (average 1.4) : 1
Polarization	Single linear
Impedance	50 Ohms
Power handling (CW)	15 W average

Mechanical characteristics

Dimensions (H x W x L)	2.5 x 2 x 8.6 cm
Weight (approx.)	0.5 Kg
Material	Aluminum
Surface treatment	Surtec 650®
Coatings	Polyurethane paint
RF connector	2.92 mm Female – Southwest 1012-16SF®

Dimensional drawing

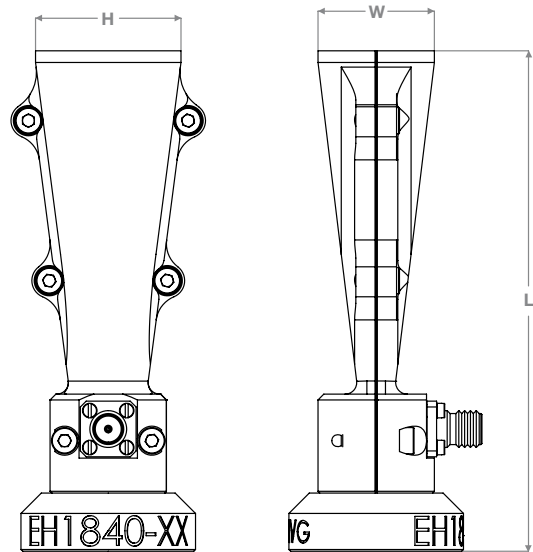

MVG - Meeting the Testing Challenges of a Fully Connected World

The Microwave Vision Group (MVG) has developed unique expertise in the visualization of electromagnetic waves. These waves are at the heart of our daily lives: smartphones, computers, tablets, cars, trains, planes - these devices and vehicles would not work without them. MVG expertise brings measurement solutions to R&D teams for the characterization of antennas and their performance within these devices, and chamber solutions for EMC testing. MVG innovation remains focused on supplying the world with the most advanced EMF measurement technology to date.

WORLDWIDE GROUP, LOCAL SUPPORT

Our teams, in offices around the world, guide and support you from purchase, through design, to delivery and installation. Because we are local, we can assure speed and attention in project follow through. This includes customer support and maintenance once the system is in place. For the exact addresses and up-to-date contact information: www.mvg-world.com/mvg-offices



Contact your local sales representative for more information
www.mvg-world.com
salesteam@mvg-world.com