

Features

- **Frequency Range**
25 MHz to 300 MHz
- **Transmit & Receive Capabilities**
emissions/immunity applications
- **Individual Calibration Included**
per ANSI C63.5 with NIST traceability
- **Three-year Standard Warranty**

Description

The AB-900A is a broadband, linearly polarized Biconical Dipole Antenna, operating over the frequency range of 25 MHz to 300 MHz. It can be used as either a receiving antenna (for EMI measurements) or as a transmitting antenna (for immunity tests) for power levels up to 50 watts.

Construction

The antenna elements are constructed using a corrosion resistant aluminum, which is powder coated for additional durability. The element design includes the requisite “gamma match” rod, which connects the element’s center rod to one of the outer elements at the inside edge of the 90 degree bend. The gamma match is necessary in order to avoid a significant “dip” in the antenna’s performance which would otherwise be present between approximately 275 and 290 MHz.

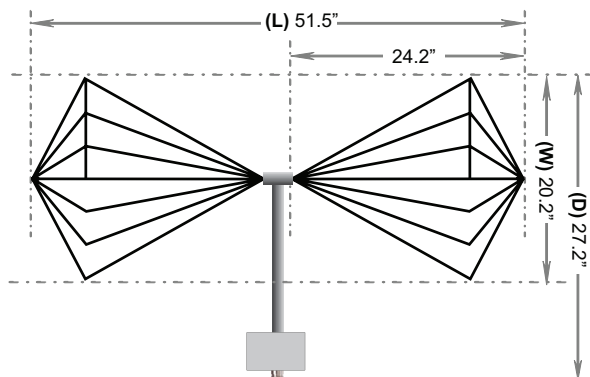

Calibration

Each antenna is individually calibrated per ANSI C63.5 with NIST traceability. The calibration data and certificate is provided. Recognized ISO 17025 accredited calibration is also available upon request.



Application

The AB-900A Biconical Antenna is intended for use as an EMI test antenna for qualification-level regulatory compliance measurements (FCC, CE, Mil-Std, RTCA DO-160, FDA, SAE Automotive, etc.).

The AB-900A can also be used in conjunction with an RF power amplifier (up to 50 watts) to generate RF fields associated with radiated immunity testing.

In addition, a pair of AB-900A Biconical Antennas can also be used for Normalized Site Attenuation (NSA) calibrations of Open Area Test Sites (OATS) or Semi-Anechoic Chambers (SAC) using the Geometry Specific Correction Factors (GSCF) given in Tables G.1 through G.3 of ANSI C63.5, as its physical dimensions fall within the minimum and maximum values given in Figure G.1 of ANSI C63.5 (Dimensions of biconical dipole antennas evaluated for numerical correction). For biconical antennas having dimensions which do not fall between these min/max values, the given GSCF values can not be used, and would need to be determined by performing GSCF calibration on a Standard Antenna Calibration Site (SACS) as described in Annex H of ANSI C63.5.

Notwithstanding the above applications, the AB-900A can also be used for test site comparisons, shielding effectiveness tests of large enclosures, field monitoring, site surveys and other general purposes.

Mounting

The recommended support structures for the AB-900A are Com-Power’s **AM-400 Antenna Mast** and **AT-812 Antenna Tripod**. One of the standard AT-812 accessories is the **ATHP-812 Antenna Pipe Holder**, which clamps securely around the one-inch diameter feed tube of the AB-900A. The ATHP-812 is then secured to a tripod or mast via its 1/4" x 20 thread mounting hole.

Specifications

Product Name	Biconical Antenna
Frequency Range	25 MHz to 300 MHz
Polarization	Linear
Nominal Impedance	50Ω
Power Handling	50 Watts Continuous
Connector	N-type (female)
Antenna Factor	[see graph below]
Isotropic Gain	[see graph below]
VSWR/Return Loss	[see graph below]
Radiated Field Strength	[see graph below]
Test Specifications	FCC, CISPR, EN, ETSI, FAA, MIL-STD 461, Automotive, etc.
Dimensions (L x W x D)	51.5" x 20.2" x 27.2" [130.8 x 51.3 x 69.1 cm]
Weight	5 lbs. [2.3 kg]

All specifications are subject to change without notice.
All values are typical, unless specified.

Accessories available from Com-Power:



PAM-103 Preamplifier



AT-812 Antenna Tripod



SPA-800 Spectrum Analyzer

Also Available:

AL-130 Active Loop Antenna
AM-741 Active Monopole Antenna
AL-100, ALP-100, ALC-100 Log Periodic Antennas

Antenna Factors

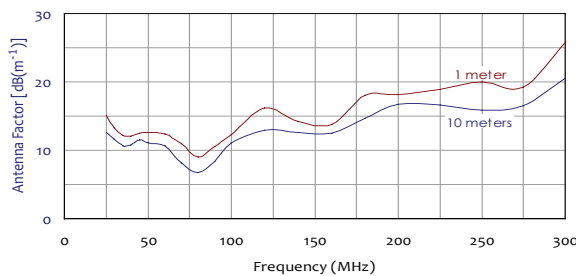

Isotropic Gain

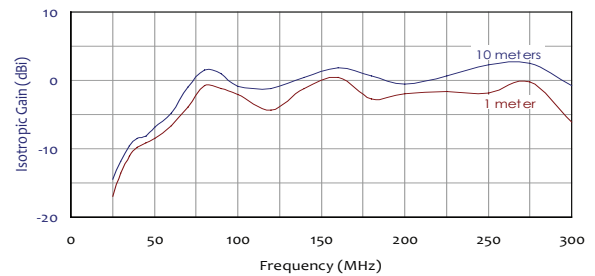

Voltage Standing Wave Ratio (VSWR)

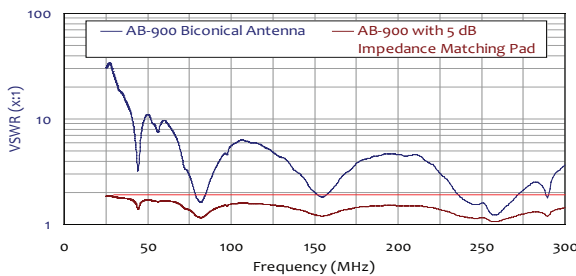

Return Loss

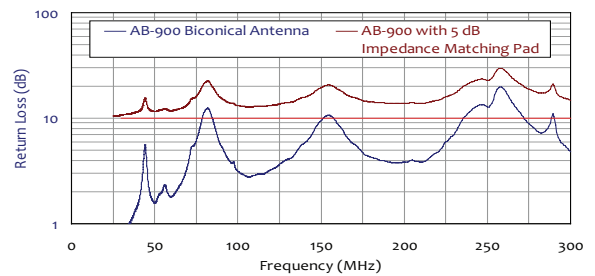

Typical Field Strength with 50W Input Power

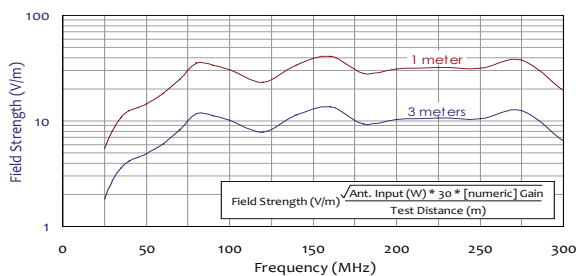

Typical Forward Power Levels

