

# OCS 500N6F SERIES

## SIMULATOR FOR FAST AND SLOW DAMPED OSCILLATORY WAVES AND RINGWAVE



### DO BADAŃ ZGODNIE Z ...

- > ANSI/IEEE C37.90
- > ANSI/IEEE C62.41
- > EN 61000-4-10
- > EN 61000-4-12
- > EN 61000-4-18
- > IEC 60255-22-1
- > IEC 61000-4-10
- > IEC 61000-4-12
- > IEC 61000-4-18
- > IEC 61000-6-5
- > IEC 61850-3
- > IEC 62052-11

### OCS 500N6FX - COMPACT TESTERS FOR FAST/SLOW DAMPED OSCILLATORY WAVES AND RINGWAVE



The OCS 500N6F series includes the test capabilities for fast damped oscillatory waves at 3 MHz, 10 MHz and 30 MHz up to 4.4kV and is extendable for slow damped oscillatory waves at 100 kHz / 1 MHz up to 3.0 kV (as per EN/IEC 61000-4-18) and for ringwave up to 6 kV as per EN/IEC 61000-4-12.

Damped Oscillatory Waves are repetitive transients mainly occurring in power, control and signal cables installed in high voltage and medium voltage stations, divided into slow and fast damped oscillatory waves. The Ringwave is a non-repetitive damped oscillatory transient occurring in low-voltage power, control and signal lines supplied by public and non-public networks.

### HIGHLIGHTS

- > Fully automated single box test system
- > Single DUT port
- > Fast Damped Oscillatory Waves up to 4.4 kV
- > Slow Damped Oscillatory Waves up to 3 kV (option)
- > Ringwave up to 6 kV (option)

### OBSZARY ZASTOSOWAŃ

- |                                                                                                |                                                                                                          |
|------------------------------------------------------------------------------------------------|----------------------------------------------------------------------------------------------------------|
|  INDUSTRY   |  RESIDENTIAL        |
|  COMPONENTS |  ENERGIA ODNAWIALNA |
|  MEDICAL    |                                                                                                          |
|  BROADCAST  |                                                                                                          |

**PARAMETRY TECHNICZNE**

**MODEL SELECTION**

**THREE IN ONE - THE OCS 500N6F COMBINES DAMPED OSCILLATORY WAVES AND RINGWAVE**

The basic equipment includes the fast damped oscillatory generator with 3 MHz, 10 MHz and 30 MHz for up to 4.4 kV acc. IEC 61000-4-18.

The OCS 500N6F comes with a built-in coupling/decoupling network for either single phase or three-phase and is rated for currents of 16 A or 32 A per line.

Optional Modules:

Slow Damped Oscillatory Waves with 100 kHz / 1 MHz reach up to 3kV. The module comply with EN/IEC 61000-4-18 and also with the requirements to test protective relays as per ANSI/IEEE C39.70.

Ringwave Module with capability of up to 6 kV complies with the Ringwave requirements of IEC 61000-4-12 ANSI/IEEE C62.41 standard.

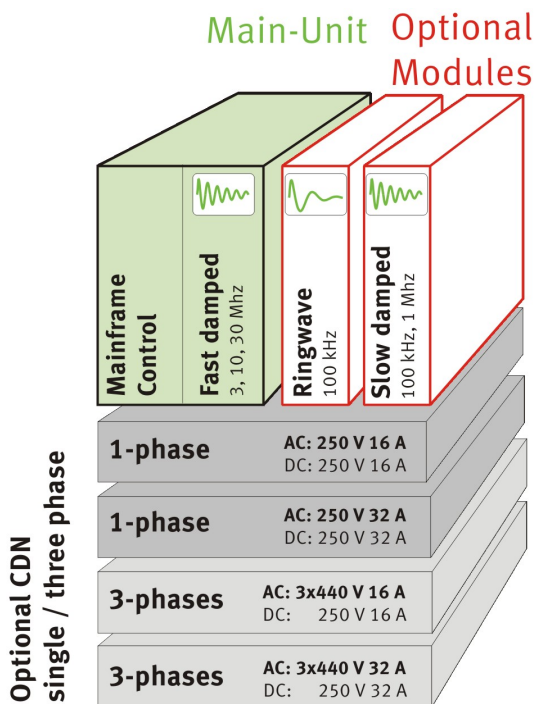

**OPERATION**

**EASY TO OPERATE**

Front panel menu and function keys enable the user to program his test routines quickly and accurately. The cursor allows fast control of all test parameters of the programmed routine, thus test procedures are simplified and confidence is generated that every step is carried out correctly.

The operating concept em.flow distinguished by the following benefits:

- > Extremely easy to operate
- > Parameters can be set even during the test
- > Quick start
- > Standard programs
- > User programs
- > Select directly from standard test levels
- > Statistical test options
- > Predefined tests



**PARAMETRY TECHNICZNE**

**SOFTWARE**

**IEC.CONTROL SOFTWARE FOR CONTROL AND DOCUMENTATION**

Outstanding user convenience, clearly structured windows and operation features and the EM TEST standards library along with the flexibility to generate user specific test sequences very easily are the main features of iec.control software. The software is automatically configured according to the connected EM TEST generators. Extensive reporting capabilities help the user to create test reports that meet international requirements.

iec.control is supported by Windows XP, Windows Vista, Windows 7 and Windows 8. Remote control is achieved either via opto-link or GPIB. iec.control supports a wide range of GPIB cards both of National Instruments.



**AUXILIARY DEVICES**

**CNV 504N4/N5 SERIE - COUPLING NETWORK FOR SIGNAL/DATA LINES**

CNV 504N5.1 and CNV 504N5.3

The CNV 504N5-series coupling/decoupling networks are used to apply slow damped oscillatory waves with a frequency of 100 kHz or 1 MHz onto signal/data lines in accordance to IEC/EN 61000-4-18.

CNV 508N4 and CNV 508N4.1

The CNV 508N4 series are special coupling/decoupling networks being used to perform "Electrical disturbance tests for measuring relays and protection equipment" in accordance to IEC 60255-22-1.

The coupling/decoupling network is equipped with 4-pairs (8 wires) for the application on to signal/data lines.



**CNV504N5.1**



**CNV508N4**

## PARAMETRY TECHNICZNE

## ACCESSORIES

**MS 100N - MAGNETIC FIELD COIL FOR DAMPED OSCILLATORY MAGNETIC FIELDS**

The MS 100N is a 1\*1 sqm magnetic field coil as specified in IEC/EN 61000-4-10. Its design allows easy moving of the coil. The field coil is adjustable in height and allows for 360 degr rotation.

The MS 100N is directly connected to the corresponding HV output of the OCS 500N6F to generate damped oscillatory magnetic fields as per IEC/EN 61000-4-10, up to level 5.



## OCS 500N6F MAIN-UNIT MODELS

OCS 500N6F	With built-in CDN AC 250 V / 16 A DC 250 V / 16 A
OCS 500N6F.1	With built-in CDN AC 250 V / 32 A DC 250 V / 32 A
OCS 500N6F.2	With built-in CDN AC 3x440 V / 16 A DC 250 V / 16 A
OCS 500N6F.3	With built-in CDN AC 3x440 V / 32 A DC 250 V / 32 A

## PARAMETRY TECHNICZNE

FAST DAMPED OSCILLATORY  
MODULEFAST DAMPED OSCILLATORY WAVES AS PER IEC/EN  
61000-4-18

Voltage (o.c.) at HV output	450 V - 4,400 V $\pm$ 10%
Rise time	5 ns $\pm$ 30%
Oscillation frequencies	3 MHz, 10 MHz and 30 MHz, $\pm$ 10%
Decaying	Peak 5 to be $>$ 50% of peak 1 value Peak 10 to be $<$ 50% of peak 1 value
Source impedance	50 ohm $\pm$ 20%
Polarity	Positive, negative
Repetition rate	Max. 5,000 /s $\pm$ 10%
Burst duration	50 ms $\pm$ 20%, at 3 MHz 15 ms $\pm$ 20%, at 10 MHz 5 ms $\pm$ 20%, at 30 MHz
Burst period	300 ms $\pm$ 20%
Short-circuit current	9 A - 88 A $\pm$ 20%
Rise time current waveform	$<$ 330 ns at 3 MHz $<$ 100 ns at 10 MHz $<$ 33 ns at 30 MHz
Decaying (current)	Peak 5 to be $>$ 25% of peak 1 value Peak 10 to be $<$ 25% of peak 1 value

SLOW DAMPED OSCILLATORY  
MODULE (OPTION)SLOW DAMPED OSCILLATORY WAVES AS PER IEC/EN  
61000-4-18 (OPTION)

Voltage (o.c.) at HV output	250 V - 3,000 V $\pm$ 10%
Voltage (o.c.) at line output	250 V - 2,500 V $\pm$ 10%
Rise time	75 ns $\pm$ 20%
Oscillation frequencies	100 kHz and 1 MHz $\pm$ 10%
Decaying	Peak 5 to be $>$ 50% of peak 1 value Peak 10 to be $<$ 50% of peak 1 value
Source impedance	200 ohm $\pm$ 20%
Polarity	Positive, negative
Repetition rate	Max. 50 /s for 100kHz and Max. 500 /s for 1MHz
Burst duration	At least 2 s

## RINGWAVE MODULE (OPTION)

RINGWAVE AS PER IEC/EN 61000-4-12 AND ANSI/IEEE  
C62.41 (OPTION)

Voltage (o.c.)	250 V - 6,000 V $\pm$ 10%
Rise time	0.5 $\mu$ s $\pm$ 30%
Oscillation frequency	100 kHz $\pm$ 10%
Decaying	Ratio of peak 2 to peak 1: 0.4 - 1.1 Ratio of peak 3 to peak 2: 0.4 - 0.8 Ratio of peak 4 to peak 3: 0.4 - 0.8
Source impedance	12 ohm and 30 ohm $\pm$ 20%
Peak current (s.c.)	Max. 500 A @ 12 ohm or Max. 200 A @ 30 ohm internally
Rise time	$<$ 1 $\mu$ s
Oscillation frequency	100 kHz $\pm$ 10%
Polarity	Positive, negative
Repetition rate	1 to 60 transients per minute

## PARAMETRY TECHNICZNE

## GENERAL SPECIFICATION

## TRIGGER CIRCUIT

Release of pulses	Automatic, manual, external
Synchronization	0° - 360°, resolution 1°

## OUTPUT

Direct	Via HV-safety lab connectors
Coupling mode	Line to line Line(s) to ground (PE)
DUT supply	
OCS 500N6F	AC: 250 V / 16 A; 50/60 Hz DC: 250 V / 16 A
OCS 500N6F.1	AC: 250 V / 32 A; 50/60Hz DC: 250 V / 32 A
OCS 500N6F.2	AC: 3x440 V / 16 A; 50/60 Hz DC: 250 V / 16 A
OCS 500N6F.3	AC: 3x440 V / 32 A; 50/60 Hz DC: 250 V / 32 A
CRO trigger	5V trigger signal for oscilloscope

## MEASUREMENTS

Ring wave	Peak voltage and peak current in LCD
-----------	--------------------------------------

## TEST ROUTINES

Quick Start	Immediate start; easy-to-use and fast
Standard Test routines	As per IEC 61000-4-18 As per IEC 61000-4-12, Level 1 - 4 Manual Standard Test routine As per ANSI/IEEE C62.41 As per IEC 61000-4-10, Level 1 - 5
User Test routines	Change polarity after n pulses Change coupling after n pulses Change voltage after n pulses Change phase angle after n pulses

## GENERAL DATA

## INTERFACE

Optical interface	Opto link, 3 m cable USB A connector
Parallel interface	IEEE 488, addresses 1 - 30

## GENERAL DATA

Dimensions, weight	19" / 9 HU, approx. 32 kg (1-phase) 19" / 9 HU, approx. 50 kg (3-phase)
Supply voltage	115/230 V +10/-15%
Fuses	2 x T2AT (230V); 2 x T4AT (115V)
Temperature	10° C to 35° C
Rel. humidity	Max. 85%, non condensing
Atmospheric pressure	86 kPa (860 mbar) to 106 kPa (1,060 mbar)

## PARAMETRY TECHNICZNE

## OPTIONS

## ACCESSORIES COUPLING NETWORK

CNV 504N5.1	Coupler for 4 signal/datalines for damped oscillatory waves 100kHz and 1MHz as per IEC 61000-4-18, 50 V / 4 A
CNV 504N5.3	Coupler for 4 signal/datalines for damped oscillatory waves 100 kHz and 1 MHz as per IEC 61000-4-18, 250 V / 4 A
CNV 508N4	Coupler for 4 pairs (8 wires) as per IEC 60255-22-1, 250 V / 4 A
CNV 508N4.1	Coupler for 4 pairs (8 wires) as per IEC 60255-22-1, 250 V / 16 A
HFK	Capacitive coupling clamp as per IEC 61000-4-4
MS 100N	Magnetic Field coil for IEC/EN 61000-4-10 application

## ACCESSORIES SOFTWARE, VERIFICATION

iec.control	Remote control and documentation software with library of standards
CA OCS F Kit	Load resistor set for fast damped oscillatory wave verification, KW 0R1 load resistor 0.1ohm, KW 1000 load resistor 1000ohm, CA MC F Adapter to match KW 0R1 and KW 1000 to the supply output of the OCS 500N6F

# KOMPETENTNI, GDZIEKOLWIEK BYŚ BYŁ

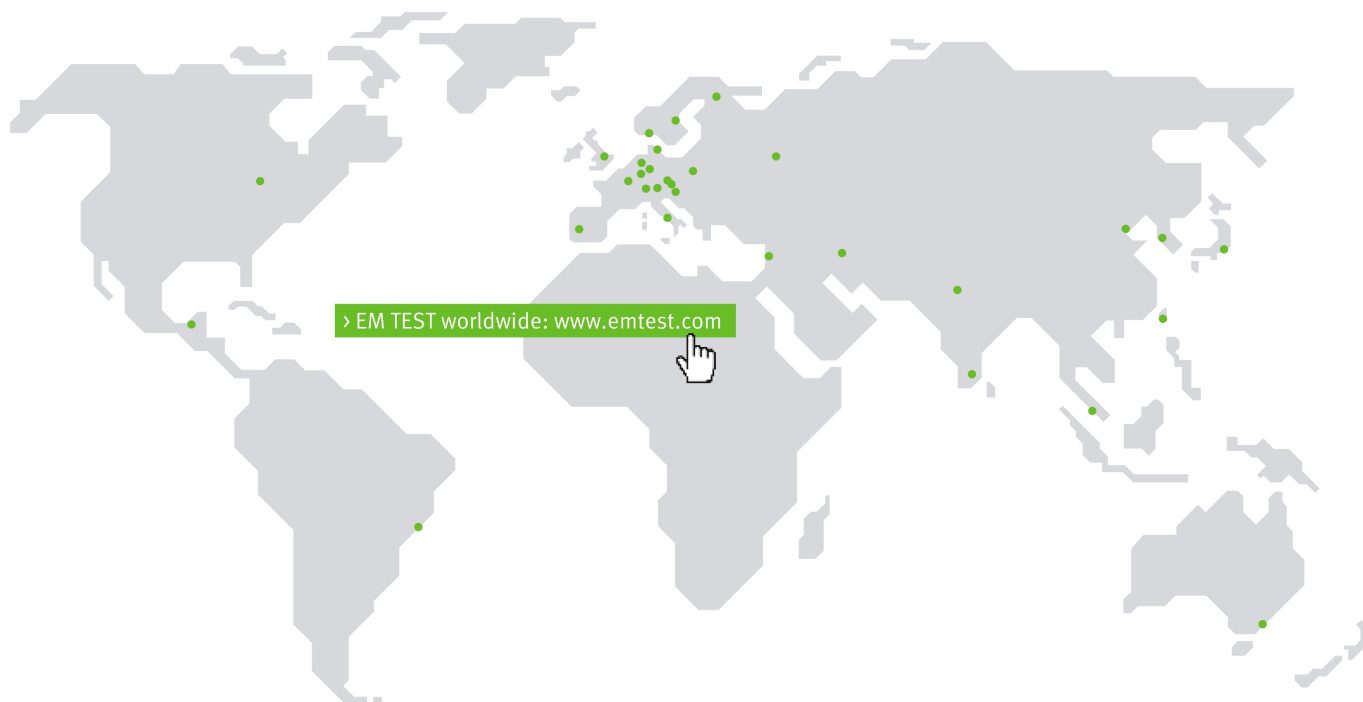

## BEZPOŚREDNI KONTAKT Z EM TEST

### Szwajcaria

EM TEST (Switzerland) GmbH > Sternenhofstraße 15 > 4153 Reinach > Switzerland  
 Telefon +41 (0)61/7179191 > Fax +41 (0)61/7179199  
 Internet: www.emtest.ch > E-mail: sales.emtest@ametek.com

### Niemcy

AMETEK CTS Germany GmbH > Lünener Straße 211 > 59174 Kamen > Deutschland  
 Telefon +49 (0)2307/26070-0 > Fax +49 (0)2307/17050  
 Internet: www.emtest.com > E-mail: info.cts@ametek.de

### Francja

EM TEST FRANCE > Le Trident - Parc des Collines > Immeuble B1 - Etage 3 > 36, rue Paul Cézanne > 68200 Mulhouse > France  
 Telefon +33 (0)389 31 23 50 > Fax +33 (0)389 31 23 55  
 Internet: www.emtest.fr > E-mail: info@emtest.fr

### Polska

EM TEST Polska > ul. Ogrodowa 31/35, 00-893 Warszawa > Polska  
 Telefon +48 (0)518 64 35 12  
 Internet: www.emtest.com/pl > E-mail: infopolska.emtest@ametek.com

### USA / Kanada

AMETEK Compliance Test Solutions > 52 Mayfield Ave. > Edison > NJ 08837  
 Telefon +1 (732) 417-0501  
 Internet: www.emtest.com > E-mail: sales.emtest@ametek.com

### Chiny

E & S Test Technology Limited > Rm 913, Leftbank > No. 68 Bei Si Huan Xi Lu > Haidian District > Beijing 100080 > P.R. China  
 Telefon +86 (0)10 82 67 60 27 > Fax +86 (0)10 82 67 62 38  
 Internet: www.emtest.com > E-mail: info@emtest.com.cn

### Republika Korei

EM TEST Korea Limited > #405 > WooYeon Plaza > #986-8 > YoungDeok-dong > Giheung-gu > Yongin-si > Gyeonggi-do > Korea  
 Telefon +82 (31) 216 8616 > Fax +82 (31) 216 8616  
 Internet: www.emtest.co.kr > E-mail: sales@emtest.co.kr

Wszystkie informacje dotyczące dostaw, wyglądu zewnętrznego i danych technicznych opisujących aktualny stan wraz z datą publikacji mogą ulec zmianie bez wcześniejszych informacji.