



NSG 3040 EMC TEST SYSTEM

USER MANUAL 601-279G

NSG 3040 EMC TEST SYSTEM

USER MANUAL 601-279G

CONTENTS

| | | |
|----------|--|-----------|
| 1 | Explanation of symbols | 9 |
| 2 | Introduction | 10 |
| 2.1 | General description | 10 |
| 3 | Standards and applications | 12 |
| 3.1 | Burst test | 12 |
| 3.2 | Combination wave test | 13 |
| 3.3 | Mains quality test | 13 |
| 3.4 | Magnetic fields with mains frequency | 14 |
| 3.5 | Pulsed magnetic fields | 14 |
| 3.6 | Slow Damped Oscillatory Wave (NSG 3040-SOW only) | 14 |
| 4 | Safety instructions | 16 |
| 4.1 | General | 16 |
| 4.2 | Installation | 17 |
| 4.3 | Installation of an EUT power switch | 18 |
| 4.4 | Applicable safety standards | 18 |
| 4.5 | Test execution | 19 |
| 4.6 | User warnings - Generator | 20 |
| 4.7 | Dangers concerning the EUT | 21 |
| 5 | First steps | 22 |
| 5.1 | Installation of the NSG 3040 system | 23 |
| 5.2 | Connecting the test system to the ground reference plane | 24 |
| 5.3 | Mounting in a 19" rack | 24 |
| 5.4 | Rear ground brackets (INA 165) | 24 |
| 6 | Mainframe description | 25 |
| 6.1 | Front panel | 25 |
| 6.1.1 | EUT output | 25 |
| 6.1.2 | High frequency ground terminal | 26 |
| 6.1.3 | Surge or SOW output | 27 |

| | | |
|----------|---|-----------|
| 6.1.4 | Burst output | 27 |
| 6.1.5 | Indicator LEDs | 27 |
| 6.1.6 | Touch screen and user interface | 28 |
| 6.2 | Rear panel | 28 |
| 6.2.1 | Instrument supply | 28 |
| 6.2.2 | EUT power input | 29 |
| 6.2.3 | DC EUT input | 31 |
| 6.2.4 | Ground connection point | 31 |
| 6.2.5 | System interface connector 25 pin D sub | 31 |
| 6.2.6 | Synchro-Bus system | 32 |
| 7 | The standard user interface (SUI) | 34 |
| 7.1 | Main menu | 35 |
| 7.2 | System window | 36 |
| 7.2.1 | GENERAL settings | 36 |
| 7.2.2 | EQUIPMENT screen | 39 |
| 7.2.3 | COMMUNICATION screen | 40 |
| 7.2.4 | MONITORING screen | 42 |
| 7.3 | Updating SUI software via the SD-card | 43 |
| 8 | Parameter setting window | 47 |
| 8.1 | The red menu bar | 47 |
| 8.2 | The bottom bar | 52 |
| 8.2.1 | Load user test | 52 |
| 8.2.2 | Load standard test | 53 |
| 8.2.3 | Save test | 56 |
| 8.2.4 | Keypad | 56 |
| 8.2.5 | Show graphic | 57 |
| 8.3 | Burst generator setting | 57 |
| 8.3.1 | Test configuration with power line coupling | 58 |
| 8.3.2 | Test configuration with external coupling | 58 |
| 8.3.3 | Burst parameters window | 59 |
| 8.3.4 | Voltage | 59 |
| 8.3.5 | Frequency | 59 |
| 8.3.6 | Phase | 59 |
| 8.3.7 | Coupling | 60 |
| 8.3.8 | Burst time | 61 |
| 8.3.9 | Repetition time | 61 |
| 8.3.10 | Test duration | 61 |

| | | |
|----------|---|-----------|
| 8.3.11 | Burst generator technical data | 62 |
| 8.3.12 | Derating | 62 |
| 8.4 | Combination wave (Surge) – parameter setting | 67 |
| 8.4.1 | Test configuration for power line coupling | 67 |
| 8.4.2 | Test configuration for external coupling | 67 |
| 8.4.3 | Voltage | 69 |
| 8.4.4 | Impedance | 69 |
| 8.4.5 | Phase | 69 |
| 8.4.6 | Coupling | 70 |
| 8.4.7 | Repetition time | 71 |
| 8.4.8 | Test duration | 71 |
| 8.4.9 | Surge generator technical data | 71 |
| 8.5 | Dips, interrupts and variations | 72 |
| 8.5.1 | Examples of dips & interrupts | 73 |
| 8.5.2 | Dips & interrupts generator | 73 |
| 8.5.3 | Voltage U Var | 74 |
| 8.5.4 | Phase | 74 |
| 8.5.5 | Repetition time | 74 |
| 8.5.6 | T-Event | 74 |
| 8.5.7 | Test duration | 74 |
| 8.5.8 | Dips and interrupts technical data | 75 |
| 8.5.9 | Variation test technical data | 75 |
| 8.6 | Power magnetic field testing (-4-8) parameter setting | 77 |
| 8.7 | Pulsed magnetic field testing (-4-9) parameter setting | 78 |
| 8.8 | Slow Damped Oscillatory Wave test (-4-18) parameter setting | 78 |
| 8.8.1 | Slow Damped Oscillatory Wave parameters window | 79 |
| 8.8.2 | Coupling | 81 |
| 8.8.3 | Output impedance | 82 |
| 8.8.4 | Timing parameters | 82 |
| 8.8.5 | Test duration | 83 |
| 8.8.6 | Phase synchronization | 83 |
| 8.8.7 | Derating | 83 |
| 9 | Description of the 25 pin D-Sub signals | 86 |
| 9.1 | Interlock | 86 |
| 9.2 | Trigger to scope output signal | 87 |
| 9.3 | Synchronization (Sync) signal: Output signal | 87 |
| 9.4 | Pulse enable/next step input | 88 |

| | | |
|-----------|--|------------|
| 9.5 | EUT fail input | 88 |
| 9.6 | EUT power off | 88 |
| 9.7 | High voltage active | 89 |
| 10 | Coupling network CDN 3041 | 90 |
| 11 | Various NSG 3040 versions | 92 |
| 11.1 | NSG 3040 IEC | 92 |
| 11.2 | NSG 3040 "a la carte" (customer specific) | 92 |
| 11.2.1 | Mainframe NSG 3040-MF | 93 |
| 11.2.2 | Mainframe for exclusive remote control NSG 3040-MF-ERC | 93 |
| 11.2.3 | Combined wave surge module CWM 3450 | 94 |
| 11.2.4 | Dips and interrupts module PQM 3403 | 94 |
| 11.2.5 | Electrical fast transient/burst module FTM 3425 | 94 |
| 11.3 | NSG 3040-xxx-ERC series | 94 |
| 11.4 | NSG 3040-xxx-EPO series | 96 |
| 11.5 | NSG 3040-DDV | 97 |
| 11.6 | NSG 3040-SOW | 98 |
| 12 | Maintenance and function check | 99 |
| 12.1 | General | 99 |
| 12.2 | Cleaning | 99 |
| 12.3 | Function check | 100 |
| 12.4 | Calibration | 100 |
| 12.5 | Warranty | 101 |
| 13 | Declaration of conformity (CE) | 102 |
| 14 | Accessories | 103 |
| 14.1 | PC software | 103 |
| 14.2 | Coupling decoupling networks for multiple phases, higher currents and voltages | 104 |
| 14.2.1 | CDN 3043 - 32 A series | 105 |
| 14.2.2 | CDN 3063 series - 63 A and 100 A series | 106 |
| 14.3 | Variable voltage source | 107 |
| 14.3.1 | Automatic Variacs | 107 |
| 14.3.2 | Manual step transformer: INA 6501 | 112 |
| 14.3.3 | Manual step transformer: INA 6502 | 116 |
| 14.4 | Magnetic field options | 121 |
| 14.4.1 | Manual solution: MFO 6501 | 125 |
| 14.4.2 | Automatic solution: MFO 6502 | 129 |
| 14.5 | Pulse wave shape adapter INA 752 | 134 |

| | | |
|-----------|---|------------|
| 14.6 | Coupling decoupling networks for data lines | 136 |
| 14.6.1 | Burst EFT coupling clamp NSG 3425 - and safety cover INA 3825 | 136 |
| 14.6.2 | Surge CDN for unsymetric datalines CDN 117 | 139 |
| 14.6.3 | Surge pulse CDN for symmetric datalines CDN 118 | 140 |
| 14.7 | Measuring accessories | 142 |
| 14.7.1 | MD 200 and MD 200A differential high voltage probes | 142 |
| 14.7.2 | MD 300 surge pulse current probe set | 144 |
| 14.7.3 | MD 310 SOW pulse current probe set | 146 |
| 14.7.4 | Burst/EFT pulse verification kit | 148 |
| 14.8 | Cables, plugs and adapters | 149 |
| 14.8.1 | Calibration adapters | 149 |
| 14.8.2 | Test adapters | 150 |
| 14.8.3 | Various cables and plugs | 151 |
| 14.9 | Mounting accessories | 153 |
| 15 | System description | 154 |
| 16 | Addresses | 156 |



WARNING - Lethal danger from high voltages and the risk of radiating illegal electromagnetic interference.

This system must be used only for EMC test purposes as specified in these operating instructions.

The NSG 3040 must be installed and used only by authorized and trained EMC specialists.

Personnel fitted with a heart pacemaker may not operate the instrument and must not be in the vicinity of the test setup while it is in operation.

When the system is used in conjunction with options, accessories or other equipment the safety instructions concerning those devices must also be observed.

1 EXPLANATION OF SYMBOLS



Please take note of the following explanations of the symbols used in order to achieve the optimum benefit from this manual and to ensure safety during operation of the equipment.

The following symbol draws your attention to a circumstance where non-observation of the warning could lead to inconvenience or impairment in the performance.

Example:



This connection must not be confused with the Equipment under Test (EUT) power input.

The following symbol draws your attention to a circumstance where non-observation of the warning could lead to component damage or danger to the operating personnel.

Example:



Never connect or disconnect the EUT while the test system is performing a test.

2 INTRODUCTION



2.1 General description

The NSG 3040 test system is a multifunction generator that simulates cable-borne electromagnetic interference effects for immunity testing to international, national, and manufacturers' standards.

The system is designed to fulfill conducted electromagnetic compatibility (EMC) test requirements for compliance testing of household, office, light industrial or commercial equipment, including combination wave surge, Electrical Fast Transient (EFT) pulses, and Power Quality Testing (PQT).

The NSG 3040's modular architecture and industry standard interfaces allow it to be easily expanded and customized to meet individual testing needs.

The system is designed as a series of interoperable function units with a master controller that handles the real time functions and communicates with the function modules. Each function unit contains a slave controller; all function units are connected together through their slave controllers and networked with the central master controller via a field bus (Interbus). Information concerning special features and their adjustable parameters are stored directly in the function modules.

This modularity enables the function units to be combined into customized test systems, and later reconfigured to address changing testing requirements. The function units can be readily modified to address the requirements of new standards, and new function units for new parameters may be incorporated in existing systems.

The NSG 3040 is controlled through its standard user interface via a touch panel display. The system can also be controlled by a remote PC via its Ethernet interface.

To ensure optimal user and equipment safety, only industry-standard and correctly specified plugs and sockets are used throughout.

3 STANDARDS AND APPLICATIONS



The NSG 3040 test system is designed primarily for cable-borne transient interference tests as specified in the European generic standards IEC/EN 61000-6-1 covering equipment for household, office and light industrial use, and IEC/EN 61000-6-2 for applications in industrial environments. The NSG 3040 generates these tests in accordance with IEC/EN 61000-4-4, -4-5, -4-11, -4-18 and -4-29, depending of the model. Accessories are available for generating optional tests to IEC/EN 61000-4-8 and -9.

The EU directive No. 2004/108/EC (for the assignment of the CE symbol) refers to these standards and to this type of equipment.

3.1 Burst test

Burst tests in compliance with IEC/EN 61000-4-4 simulate the high voltage/high frequency interference pulses typically produced when an inductively loaded switch is operated. Without countermeasures, such interference may occur when a current through an electromagnetic device, e.g. motor, circuit breaker, relay, fluorescent lamp, etc. is switched off.

This type of interference can affect other equipment in either of following two ways. Firstly, the interference can be coupled directly into the target equipment via the mains power cable. The interference can be transmitted from the source along the mains power cable connected to the target. Interference from the mains can reach any other piece of equipment connected to the same power source in a similar way, however this does not all have to occur in the same section of a building.

Alternatively, the interference can be capacitively coupled into any target device in the vicinity.

The system enables a test to be performed using both standardized coupling

methods. The EUT is connected to the mains power socket on the front panel of the test system for the direct mains injection test. Capacitively coupled tests require the interference to be superimposed onto the signal or data line cables via an external coupling clamp that is connected to the burst output on the front panel of the system.

3.2 Combination wave test

The surge test, in compliance with IEC/EN 61000-4-5, duplicates high voltage/high energy interference as experienced with a lightning strike. Generally speaking the interference finds its way into household equipment via the mains power supply.

This kind of interference can affect equipment in either of two ways. Firstly, the interference can be coupled directly into the equipment via the mains supply. The interference is conveyed directly from the source (e.g. lightning strike to external power cables). Every item of equipment connected to this power source will be affected by the interference pulses.

Alternatively, the pulses from the source of the interference or its associated mains cables can be coupled into other equipment positioned nearby.

Surge pulse interference can also occur on signal and data lines through coupling effects and electrical discharges.

The system enables tests to be carried out using both coupling methods. The EUT is connected to the mains power socket on the front panel of the test system for direct mains injection tests. Externally coupled tests require the interference to be superimposed onto signal/data line cables via an external coupling unit that is connected to the surge output on the front panel of the system.

3.3 Mains quality test

The mains quality test includes the simulation of dips and interrupts of the mains power supply in accordance with IEC/EN 61000-4-11 and for DC power supplies in accordance with IEC/EN 61000-4-29.

A voltage dip occurs when the supply voltage falls considerably below the

nominal level for a relatively short time, e.g. for a few cycles, whereas an interrupt means that the voltage falls to zero for a similar period.

3.4 Magnetic fields with mains frequency

Mains frequency magnetic field tests, or POWERM tests, involve the simulation of the magnetic fields typically generated by the current flow in power supply cables as specified in IEC/EN 61000-4-8. Such magnetic fields can affect the operation of items of equipment that are sensitive to them. The NSG 3040 performs this test by causing a heavy current to flow in a magnetic field coil such that the current and frequency produce a proportional field within the coil parameters.

The magnetic field coils, available as accessories, are connected to the magnetic field option (MFO) which, in turn, is connected to the system.

3.5 Pulsed magnetic fields

Tests with pulsed magnetic fields, or PULSEM tests, simulate the type of interference produced by surge pulses as a result of lightning strikes to buildings and other metallic structures such as freestanding masts, ground conductors, grounding networks, etc. as specified in IEC/EN 61000-4-9. Magnetic fields of this type can upset the operation of installations that find themselves within such fields. The NSG 3040 performs this test by causing a heavy current to flow in a magnetic field coil such that the amplitude of the pulse current produces a proportional field within the coil parameters.

The magnetic field coils, available as accessories, are connected to the surge pulse output socket via an INA 752 pulse shaping network.

3.6 Slow Damped Oscillatory Wave (NSG 3040-SOW only)

The damped oscillatory wave phenomena are divided into two parts. The first part is referred to as the slow damped oscillatory wave (SOW) and includes oscillation frequencies of 100 kHz and 1 MHz. The second part is referred to as the fast damped oscillatory wave (FOW), and it includes oscillation frequencies 3 MHz, 10 MHz and 30 MHz.

The slow damped oscillatory wave immunity test simulates switching of disconnectors in HV/MV open-air substations, and is particularly related to the

switching of HV busbars, as well as to the background disturbance in industrial plants as specified in IEC/EN 61000-4-18 and ANSI C37.90.1.

15

The NSG 3040-SOW is not only able to perform the slow damped oscillatory wave immunity test according to both of these standards, but includes a wide range of over-testing capabilities like higher pulse voltage, higher pulse repetition rates and a selectable source impedance for tests closer to reality conditions.

4 SAFETY INSTRUCTIONS



The NSG 3040 system and its accessories operate at high voltages.



WARNING - Improper or careless operation can be fatal!

These operating instructions form an essential part of the equipment and must be available to the operator at all times. The user must obey all safety instructions and warnings.

Neither Teseq AG, Luterbach, Switzerland, nor any of its subsidiary sales organizations can accept any liability for personal, material or consequential injury, loss or damage that may result from improper use of equipment and accessories.

4.1 General

The NSG 3040 must be operated only by authorized and trained specialists.

The generator is to be used only for the purpose specified by the manufacturer. The user is directly responsible for ensuring that the test setup does not cause excessive radiated interference which could affect other instrumentation. The test system itself does not produce any excessive EM radiation. However, the injection of interference pulses into a EUT can result in it and/or its associated cables radiating electromagnetic radiation. To avoid unwanted radiation, the standards organizations recommend that the test setup be operated inside a Faraday cage.



WARNING - NSG 3040 is not suitable for use in an explosive atmosphere.



WARNING - Personnel fitted with a heart pacemaker must neither operate the instrument nor approach the test setup while a test is being executed.

Only approved accessories, connectors, adapters, etc. are to be used to ensure safe operation.



WARNING - Connect the EUT only after the initial system self test has finished.

4.2 Installation

The NSG 3040 test system conforms to protection class 1. Local installation regulations must be respected to ensure the safe flow of leakage currents.



WARNING - Operation without a ground connection is forbidden!

Two independent ground connections are necessary - one for the test system and one for the EUT. These must be connected back to the local permanent installation or to a fixed, permanent ground conductor.

Operate the equipment only in dry surroundings. Any condensation that occurs must be allowed to evaporate before putting the equipment into operation. Do not exceed the permissible ambient temperature or humidity levels. Use only officially approved connectors and accessory items.

Ensure that a reliable return path for the interference current is provided between the EUT and the generator. The ground reference plane and the ground connections to the instruments, as described in the relevant test standards, serve this purpose well.

The test system may only be opened by a qualified specialist upon specific instruction given by the manufacturer. Since the instrument works, on principle, with two independent power supplies (one for the generator and one for the EUT), the NSG 3040 must be disconnected from both sources before any modifications to the test setup are undertaken. Besides the mains connections themselves, certain components also operate at high voltages, and are not provided with any form of extra protection against accidental contact.

4.3 Installation of an EUT power switch

The EUT input should be connected through a properly rated power switch device, which should be located close to the test setup. In order to ensure easy and quick access to the EUT power, the switch should be clearly and visibly labeled as "EUT power ON/OFF".

The in-house power distribution must be equipped with a proper circuit breaker and an emergency off button as per IEC 61010-1:2001.



The test setup should only be accessible to trained personnel.

Dimensioning of the mains supply and rating of fuse protection of the AC or DC power supply must conform with local electrical codes and EUT requirements. Inappropriate arrangement, mounting, cabling or handling of the EUT or ground can hamper or negate the effectiveness of the NSG 3040's safety features.

4.4 Applicable safety standards

Development and manufacture is in compliance with ISO 9001.

The system complies with the safety requirements of IEC/EN 61010-1 (Safety requirements for electrical equipment for measurement, control and laboratory use).

It is the user's responsibility to ensure that the test rig does not emit excessive electromagnetic interference (EMI) that might affect other equipment. The test

system itself does not produce any excessive radiation; however, the injection of interference pulses into the EUT can result in the device and/or its associated cables radiating EMI. To avoid radiating unwanted interference the standards organizations recommend that the test setup be located in a Faraday cage.

Since the purpose of the test system is to produce interference signals for interference immunity testing, the requirements in the IEC/EN 61000 series concerning limiting the radiated EMI can only be complied with by operating the test system inside a Faraday cage.

4.5 Test execution



WARNING - The test area must be organized so that unauthorized persons do not have access during the execution of a test. If a safety contact (Interlock) is used as a means of access control to the test zone (e.g. a Faraday cage), then an additional contact connected in series is necessary to provide protection for parts of the EUT that are likely to be touched accidentally.

During a test, the EUT together with its accessories and cables are to be considered live at all times. The test system must be stopped and the EUT supply disconnected before any work can be carried out on the EUT. This can be achieved simply by opening the interlock circuit.

The EUT is to be tested only in a protective cage or under a hood which provides protection against electric shock and all manner of other dangers pertaining to the particular EUT (see: User warnings - Generator).

The user must observe safety instruction for all the instruments and associated equipment involved in the test setup.

Test setup configuration is to be strictly in compliance with the methods described in the relevant standard to ensure that the test is executed in a compliant manner.

4.6 User warnings - Generator



WARNING - Users must be aware of the following dangers that can occur during testing:

- Local burning, arcing, ignition of explosive gases.
- EUT supply current surge caused by a flashover or breakdown resulting from the superimposed high voltage.
- Disturbance of other, unrelated electronics, telecommunications, navigational systems and hear pacemakers through unnoticed radiation of high frequency energy.
- In the test system the interference voltage, corresponding to the level called for in the relevant test specification, is superimposed also on the EUT's protective earth conductor. Earth contacts or pins (e.g. as in German and French mains plugs) as well as the EUT earth itself can therefore be at an elevated voltage level that would make touching dangerous. In many power connectors even the screws are linked to the protective earth.

Warning symbols on the test system:



CAUTION! Warning of a danger spot
(refer to the documentation).



Caution! Warning of electrical hazards!



WARNING - Users must be aware of the following dangers that can occur during testing:

- EUTs are often functional samples that have not yet been subjected to safety tests. It is therefore possible that the EUT could be damaged by internal overloads or may even start to burn.
- As soon as the EUT shows signs of being disrupted the test should be stopped and the power to the EUT switched off.
- Internal disruption of the electronics can result in the interference voltage or the EUT supply voltage being present on the EUT's outer casing.
- Electrical breakdown or arcing from connections that are overstressed voltage-wise during the test.
- Explosion of components with fire or fragmentation as a result of energy dissipated, e.g. from the resultant supply current or ignition of vaporized plastic materials.
- Faulty behaviour by the EUT, e.g. a robot arm strikes out or a temperature controller fails, etc.



The user is responsible to control the rating and the integrity of all cables connected to the NSG 3040 generator, especially cables connected to the Surge/SOW output, Burst output or EUT Power output.

5 FIRST STEPS



This chapter contains a short checklist with steps that should be taken before the instrument is switched on and put into operation.

Check the packaging for signs of damage in transit. Any damage should be reported immediately to the transportation company.

Lift the NSG 3040 test system out of its packaging by grasping of the mounted grips.



NOTE: Do not dispose of packaging materials. All packaging should be retained in the event that the instrument or any of its accessories should need to be returned to a Teseq service center for repair or calibration.

Using the following list, check that all the items ordered have been delivered:

1. NSG 3040 generator
2. User manual (may be a pdf on WIN 3000 CD)
3. 1 Mains power cable for the test system
4. 1 Dummy plug (interlock blind connector)
5. 1 Grounding strip 10 cm
6. 1 EUT power input connector with cable
7. 1 EUT power output connector
8. WIN 3000 CD and LAN crossover cable
9. Optional items, as ordered

Check the instrument for signs of transport damage. Any damage should be reported to the transportation company immediately.

5.1 Installation of the NSG 3040 system

The mains power voltage indicated on the instrument must correspond with the local supply voltage (mains voltage: 85–265 VAC, universal power unit, mains frequency: 50–60 Hz).

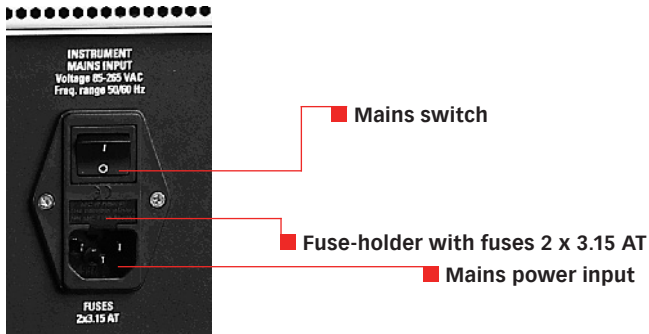

Mains switch, fuse holder and power input

To replace a fuse:

- 1) Disconnect the mains cable
- 2) Pull the fuse holder out of the connector
- 3) Remove the damaged fuse(s)
- 4) Insert 1 or 2 x 3.15 AT fuses
- 5) Replace the fuse holder
- 6) Plug the mains cable into a power outlet with a solid ground connection
- 7) Switch the system on and operate as instructed in this manual



NOTE: Place the test system so that there is sufficient free space around the cooling air inlets on both sides and behind the fan outlet on the rear panel.



NOTE: In case the test system is being used without an Emergency Stop device, make sure to place the system such as the operator has quick access to its power supply switch.



NOTE: Your NSG 3040 generator has been delivered with a correctly rated power supply cable. If the cable needs to be replaced, the user needs to make sure the new cable is suited for the rated supply voltage and current.

5.2 Connecting the system to the ground reference plane

For burst tests, the generator must be placed on a ground reference plane which is connected to ground. A good high frequency ground connection between the test system and the ground reference plane (GRP) is absolutely essential for performing burst tests correctly.

Connect the ground terminal on the front panel of the NSG 3040 to the ground reference plane using the link and bolts supplied. If a CDN is connected please refer to section "High frequency ground terminal".

5.3 Mounting in a 19" rack

When the NSG 3040 test system is combined with other equipment, it can be useful to mount the instrument in a 19" rack. The unit is 19" wide and 5U in height. An optional rack mount INA 166 kit is available.

5.4 Rear ground brackets (INA 165)

Rear ground brackets are optionally available to position the NSG 3040 securely without damaging the connectors when it must be placed with the rear panel on the floor with easy access to the touch screen. These brackets guarantee a solid ground connection to the GRP. The stable housing construction allows the operator to make use of both back brackets as well as the handles.



6 MAINFRAME DESCRIPTION



The housing of the NSG 3040 is specially designed for EMC application and is EMC approved.

6.1 Front panel

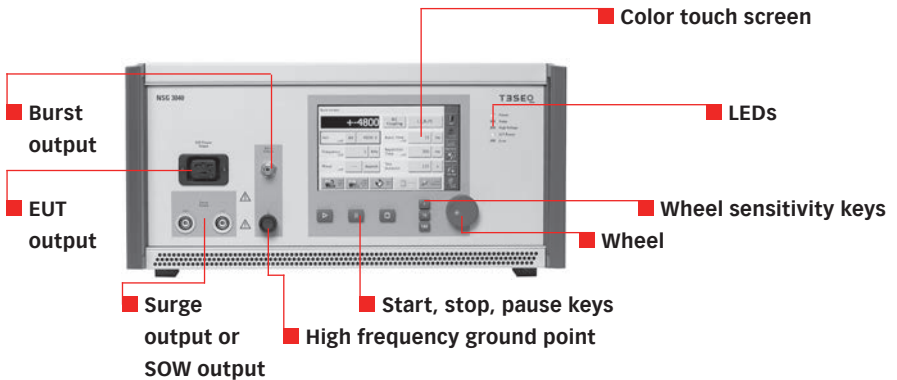

6.1.1 EUT output

This is the power output connection for the EUT.

An EUT mains power connector is included with the system. The connector contains a phase pin (L: Live), Neutral pin (N) and a ground pin for connection of the EUT. The pins in the connector must be correctly wired to the corresponding conductors in the EUT power cable.

If the test system is connected to a DC power source as supply for the EUT, the user must ensure that the polarity at this connector corresponds with that at the EUT power connector.

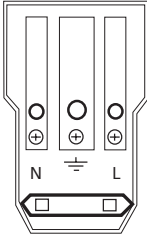

EUT output connection

Note: For DC power supply L = positive (+), N = negative (-).

The pins in the connector are designed for a maximum current of 16 A.



WARNING - Never attempt to connect or disconnect an EUT while a test is being performed.

6.1.2 High frequency ground terminal

This terminal provides a solid high frequency ground connection point to the test system. If an external CDN is connected then the ground strap must be connected from the CDN to the reference ground plane. There is no need to connect the ground connector from the generator itself, since the burst connector provides the reference ground from the generator to the CDN.



Reference ground terminal

The NSG 3040 can be efficiently connected to the GRP using the ground strap supplied with the system.

This ground link must be used for burst tests to obtain reproducible test results.

NSG 3040 EMC test system

6.1.3 Surge or SOW output

NSG 3040 models including CWM 3450 (Combination Wave/Surge Module)

These sockets (high, low) connect the surge output signal to an external CDN or to another external coupling unit.

These sockets are also used to connect the internal generator to the optional magnetic field coil for tests with pulsed magnetic fields.

The surge output is potential free (floating). The inner conductor of each connector is the surge high and surge low connection respectively, while the outer conductor (screen) is connected to the NSG 3040's ground terminal.

NSG 3040-SOW

For the NSG 3040-SOW models, both of these sockets are used to connect the slow damped oscillatory wave signal to an external coupling device.

The surge output is potential free (floating). The inner conductor of each connector is the surge high and surge low connection respectively, while the outer conductor (screen) is connected to the NSG 3040's ground terminal.

6.1.4 Burst output

This socket connects the instrument to an external burst coupling clamp for capacitive coupled burst tests on data lines, or to an external coupling network

Note: For NSG 3040-SOW models the Burst output is inactive.

6.1.5 Indicator LEDs

| LED indicator | Function |
|----------------------|--|
| Power on: | Instrument/system in operation |
| Pulse: | Shows the occurrence of pulses or a test event |
| High voltage active: | Shows that high voltage is present in the instrument |
| EUT-Power on: | Indicates when the EUT power supply is present at the EUT connector on the front panel |
| Error: | Indicates that a system error has occurred |

The LEDs switch on and off during the boot period and when errors occur.

6.1.6 Touch screen and user interface

The color 7" touch screen display controls include a wheel and 3 sensitivity keys used to 1, 10 or 100 steps per wheel click. The Start, Stop, and Pause keys are used to control the procedure.

All user interface function menus and sub-menus are described in "The standard user interface SUI".

6.2 Rear panel

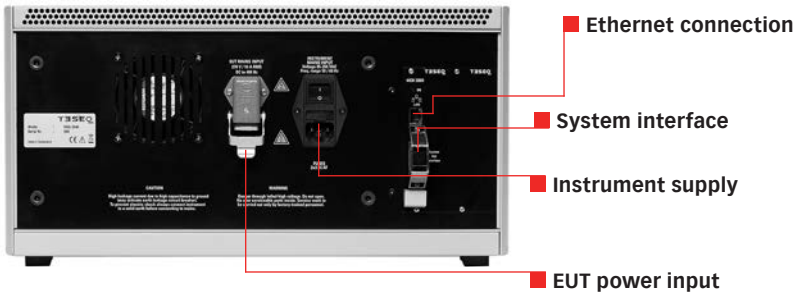

6.2.1 Instrument supply

This input is to power the instrument.



NOTE - Do not confuse the Mains power input with the EUT power input.

This input contains the fuses and the instrument ON/OFF switch.



WARNING - Before operating the NSG 3040, make sure that the voltage shown on the mains input module corresponds with the voltage of the local supply to which the instrument will be connected, and that the fuses are correctly rated (2 x 3.15 AT).

6.2.2 EUT power input

This input is the connection point for the power source which supplies power to the EUT. The 4-pin connector is a special 16 A type. A mating plug with 2 m of cable for supplying the EUT from a normal mains outlet is included with the system.

The connector is comprised of the pole contact (La, No.1), the variable voltage pole contact (Lb, No.3), the neutral return contact (N, No.2) and the ground connection to the EUT. The zero cross reference for synchronization purpose is taken all the time from La to N.

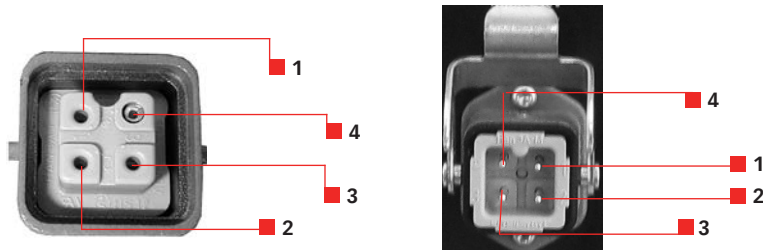

EUT mains input

- 1 La = Phase (black)
- 2 N = Neutral (blue)
- 3 Lb = Variable voltage pole (red/or brown)
- 4 = GND - Earth (green/yellow)

Wire colors and functions

| | | | |
|---------------|-----------------------|----|-------|
| Black: | Phase conductor | La | Pin 1 |
| Blue: | Neutral return | N | Pin 2 |
| Red or brown: | Variable voltage pole | Lb | Pin 3 |
| Green/yellow: | Ground conductor | PE | Pin 4 |

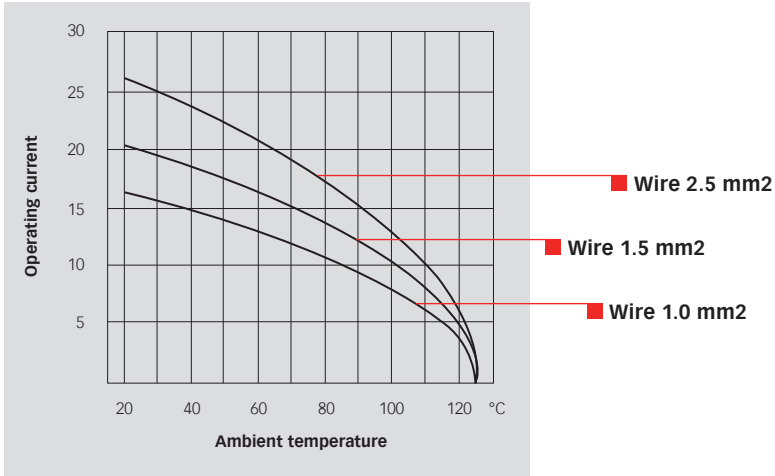

The additional variable voltage pole contact (Lb, No.3) enables a variac or alternative source to be connected for PQT tests.



WARNING - Pulse overshoot spikes of up to 630 V can occur on these power lines. Such voltages can, under certain circumstances, destroy power supplies. It is the user's responsibility to provide adequate protection at the source input.



Capacitors in the coupler can cause ground leakage currents of up to 4 A the EUT power supply network. The test system must therefore be properly grounded and powered from a supply that is not protected by a residual current detector (RCD).

The power source to this connector provides the power for the EUT. Burst and surge interference signals are coupled into this supply line internally. Power is also delivered via this route for PQT (mains quality) testing purposes.

6.2.3 DC EUT input

For DC voltages: La = positive (+), N = negative (-)

In DC applications, the positive and negative lines are to be connected to La and N respectively. The polarity at this EUT power input connector will be the same at the EUT output connector.

The connector's ground contact must be connected to a good, solid ground point.

6.2.4 Ground connection point

This ground terminal provides a solid connection point to the NSG 3040's chassis ground.

6.2.5 System interface connector 25 pin D sub

| Pin # | Sync.line | Signal | Remark | Working direction |
|-------|-----------|-------------------------|--|--|
| 7 | Sync0 | Mains synchronization | Mains voltage passes through the zero crossing point with rising signal level | From a coupling network |
| 5 | Sync1 | Interlock | Puts the NSG 3060 into an idle state. The "Error" LED lights in this state | From each controller/ to interlock circuit |
| 6 | Sync2 | EUT fail | EUT reports a fault to the NSG 3060 software. The test is stopped | From EUT to master controller |
| 18 | Sync3 | Trigger to oscilloscope | External device receives the Trigger-to-Scope signal from the generator | To/from the active function module, the slave controller and master controller |
| 17 | Sync4 | Pulse enable | External device stops the test run | From external device to the slave and master controllers |
| 4 | Sync5 | EUT power OFF | Connecting this PIN to GND24S will force the EUT power to OFF. Note: First EUT power needs to be switched ON via the instrument front panel or WIN 3000 Software, This allows dual drive, as then the EUT power can be switched OFF and ON either from software control or from this external signal drive. | From external device to the slave and master controllers |

| Pin # | Sync.line | Signal | Remark | Working direction |
|--------------|-----------|------------------|----------------------------------|--|
| 16 | Sync6 | High voltage ON | Output is High when HV is active | Output to drive INA 3001 warning lamps |
| 3 | Sync7 | Reserved | Internal usage (debug mode) | |
| 2, 8, 15, 20 | | GND | Sync bus ground return | |
| 1, 9, 14, 21 | | + 24 V | Interbus +24 V supply | |
| 19 | | Interlock return | Interlock return line | |
| All others | | Interbus lines | | |

See chapter “System interface connector functions”, for more detail.

6.2.6 Synchro-Bus system

This connection includes external device control and interlock capability. If the NSG is used only as a stand alone unit, the termination connector needs to be plugged otherwise the unit will not start.

All connected accessories will be detected automatically. Written tests are linked with this accessories so if other accessory is connected, it may get an error if the test contains not the suitable accessories.

Any automated CDN and complementary automated equipment like variac, step transformer etc. need to be linked together. Thereby the termination connector needs to be moved to the system output plug of the last unit of the system.

The interfaces for the interbus, interlock and synchro-bus are bundled together in a sub D-connector. These three interfaces are looped through from one instrument to another.



NOTE - Good EMC engineering practices should be applied when connecting signals to this port. As the whole system generates disturbances, in order to avoid auto disturbing, all wires connected to this port should be properly shielded, the shield of the cable should not serve as signal return path and the shield should be connected via a large surface to the conductive shell of the Sub-D plug.

7 THE STANDARD USER INTERFACE (SUI)



The NSG 3040 Standard User Interface (SUI) consists of

- A 7" color touch panel
- A wheel for setting parameters
- A wheel sensitivity keys labeled 1, 10, and 100 to denote the units
- A Start key to start tests
- A Stop key to stop tests
- A Pause key to pause tests



■ Start key

■ Pause key

■ Stop key

NSG 3040 touch touch screen, keys and wheel



CAUTION – Never use a metal, sharp or pointed tool for touching the panel. Use a soft towel for cleaning. Never use aggressive cleaning liquids.

As soon as the unit is powered and switched on, the boot procedure starts (approx. 30 s) and the Start menu is displayed.



SUI boot-up screen

7.1 Main menu

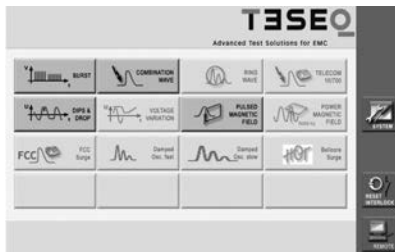

Main menu NSG 3040-IEC

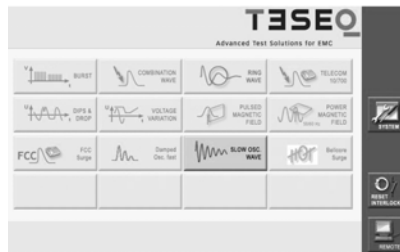

Main menu NSG 3040-SOW

The main menu is displayed following boot-up. The main menu shows the possible pulses or tests which are available to the user, depending on the NSG 3040's configuration. Faded generator icons (Telecom 10/700 μ s pulse and voltage variation) mean, that the generator is configured to generate those pulses but the proper unit is not connected.

In the red vertical bar there are three buttons, "System", "Reset Interlock" and "Remote". Touching the reset interlock button will close the interlock. The interlock link must be closed before starting a test.

Touch "Remote" button to enter remote controlled screen. No inputs via touch panel are possible. The NSG can now be controlled via WIN 3000 remote control software. Touch "Exit" on screen and in WIN 3000 to use NSG manually.

7.2 System window

Touch the “System” button to display the “System” window:

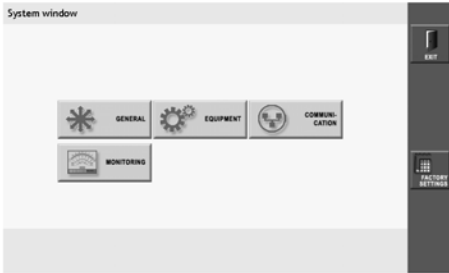

System window

The “System” window displays 4 buttons: GENERAL, EQUIPMENT, COMMUNICATION and MONITORING. In the red bar there are two buttons: FACTORY SETTINGS and EXIT.

FACTORY SETTINGS

Touch the FACTORY SETTINGS button to reset the properties associated with each of the buttons in the System window to the original factory settings.

EXIT

Touch the EXIT button to return to the main menu.

7.2.1 GENERAL settings

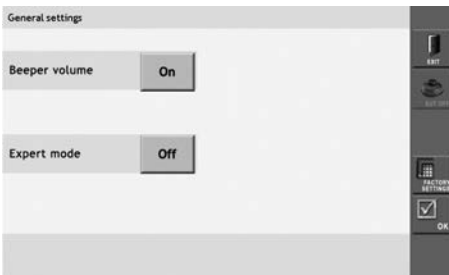

General settings window when no optional hardware (CDN, variac, etc.) connected.

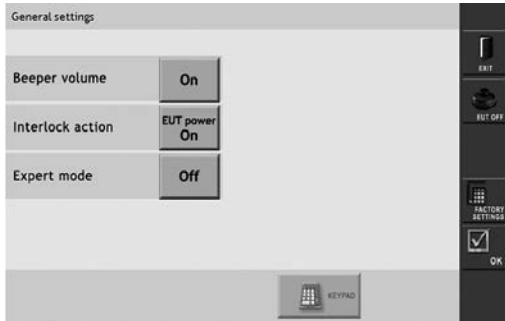

General settings window when an EUT power switch has been detected.

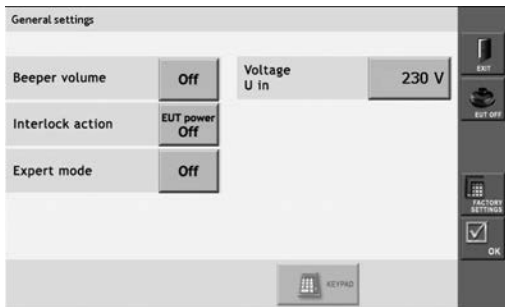

General settings window when automated variac is connected.

Beeper volume

During the surge test there is a beep sound to alert the user. Touch the "Beeper volume" button to switch the sound on and off. Default setting is "On", for safety purpose.

The red vertical bar on the right side of the General settings window displays 4 buttons: "Exit", "EUT OFF/ON", "Factory Settings", and "OK".

Interlock action

Touch the "Interlock action button" ("EUT power On" in the example) to keep EUT power on when the interlock is activated, or to have it automatically shut off ("EUT power Off") when the interlock is activated.

Expert mode

Change the “Expert mode” status to “Active” to change parameters during a running test. When the button is set to “Off” parameters can be changed only when the NSG 3040 is in Stop mode. Expert mode is only available for burst pulses (EFT).

Voltage U in

This button is active only when an optional automated VAR 6502 or VAR 3005 variac is connected to the NSG 3040. The value entered in this field is the voltage measured at the mains socket and is used as the 100% reference point for voltage variation tests.

Touch the “Voltage Uin” button (“230” in the example). Use the wheel or keypad to set the input voltage.

Uin setting will be saved and is valid for all following tests. Uin are changeable via WIN 3000 (dialogue) to be used in sequence mode.

EXIT

Touch the “Exit” button to return to the system window without saving settings.

EUT ON/OFF

The “EUT ON/OFF” button is used only when an option with a built-in EUT switch, such as an INA 6502, a CDN 3043 or a VAR 3005, is connected to the NSG 3040.

The NSG 3040 itself does not have an EUT switch. Touching the button will turn the EUT switch on or off.

FACTORY SETTINGS

Touch the “FACTORY SETTINGS” button to reset the properties associated with each of the buttons in the general settings window to the original factory settings.

OK

Touch the “OK” button to save all settings and return to the system window.

7.2.2 EQUIPMENT screen

| Equipment detail | | | | | |
|------------------|------------|------------|--------------|----------------|-----------------|
| Module Type | FW Version | Serial No. | 1. Cal. Date | Last Cal. Date | Certificate No. |
| SUI 3000 | 080313 | NA | NA | NA | NA |
| MODMC_MU | 0001.23A | 357 | 4.5.2007 | 4.5.2007 | V.Bayer |
| HVS6601 | 0001.14g | 1 | 1.1.2003 | 1.1.2003 | V.Bayer |
| EFT6601 | 0001.14g | 14 | 1.1.2003 | 1.1.2003 | V.Bayer |
| RW6601 | 0001.14k | 000000 | 1.1.2003 | 1.1.2003 | V.Bayer |

Equipment window

Touch the “Equipment” button to access a list of all internal and external generator modules, including firmware versions, serial numbers, calibration dates and certificate numbers.

The red vertical bar on the right of the equipment window displays three buttons: “Exit”, “Up” and “Down”.

EXIT

Touch the “Exit” button to return to the system window.

UP/DOWN

If the system includes more than 5 modules, touch the “Up” and “Down” arrows to scroll through the list.

Viewing the current SUI version

See entry starting with “SUI 3000” under column “FW Version” (in the example above: 080313).

7.2.3 COMMUNICATION screen

| Communication | | | |
|---------------|-------------------|---------|-----------|
| IP Address | 172.20.65.32 | SubNet | 255.0.0.0 |
| Port | 1025 | Gateway | 0.0.0.0 |
| MAC Address | 00.0C.D2.00.03.57 | | |

EXIT

FACTORY SETTINGS

OK

Communication window

Touch the “Communication” button to view and enter the network address information required to integrate the NSG 3040 into a local area network or connect it to a PC.

By touch the IP address-, SubNet-, Port- or Gateway-field the key board will appear and the new numbers can be added. To enter a new address only the number key and the dot may be used.

After touching “Enter” the keypad will close and the new setting are saved. The “Del” key will delete all text entered. The backspace button (<-->) will delete the last letter entered. Touch the “cancel” button to return to the test parameter window without saving the parameters.

IP address

An IP address (Internet protocol address) is a unique address that certain electronic devices use to identify and communicate with each other on a computer network utilizing the Internet Protocol standard (IP). Any participating network device must have its own unique address. Touch the “IP Address” button to enter the IP address. Enter the IP address using the virtual keypad and confirm with “Enter”.

Subnet

A subnet is a logical grouping of connected network devices which is used to partition networks into segments. Devices on a subnet share a contiguous range of IP address numbers.

A subnet mask defines the boundaries of an IP subnet and hides the network address portion of an IP address. For example, if a network has a base IP address of 192.168.0.0 and has a subnet mask of 255.255.255.0, then any data going to an IP address outside of 192.168.0.X will be sent to that network's gateway.

Touch the "SubNet" button to enter the subnet mask. Enter the subnet mask using the virtual keypad and confirm with "Enter".

Gateway

A gateway is a node on a network that serves as an entrance to another network. In enterprises, the gateway is the computer that routes the traffic from a workstation to the outside network that is serving the Web pages. In homes, the gateway is the ISP that connects the user to the internet.

In enterprises, the gateway node often acts as a proxy server and a firewall. The gateway is also associated with both a router, which use headers and forwarding tables to determine where packets are sent, and a switch, which provides the actual path for the packet in and out of the gateway.

The gateway address is usually set at 0.0.0.0. Touch the "Gateway" button to enter the gateway address. Enter the gateway address using the virtual keypad and confirm with "Enter".

Port

Network ports can be either physical or virtual connection points. The NSG 3040 has a physical Ethernet port that allows it to be connected to a PC or router.

The port address for the NSG 3040 should be set to 1025. Touch the "Port" button to enter the port number. Enter the port number using the virtual keypad and confirm with "Enter".

MAC address

Media Access Control (MAC) technology provides a unique identification and access control for devices on an IP network. This address cannot be changed. Media Access Control assigns a unique number, the MAC address, to each network adapter.

7.2.4 MONITORING screen

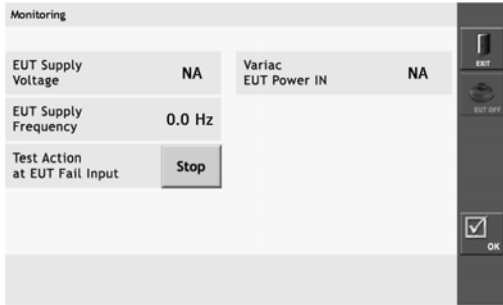

Monitoring window

Touch the “Monitoring” button to view EUT power input parameters, and to control test activity and EUT power input in the event of EUT failure.

EUT Supply Voltage, EUT Supply Frequency

In case a CDN 304x series, CDN 306x series or an INA 650x is connected to the NSG 3040, the “EUT Supply Voltage” field displays the actual EUT voltage when the AC EUT input supply is connected and EUT power is switched “On”. When the input supply is not connected and/or the EUT is switched off, these fields will display NA.

The EUT Supply frequency field shows the measured frequency of the EUT supply voltage.

Test Action at EUT Fail Input

Touch the “Test Action at EUT Fail Input” button (“Stop” in the example) to specify the test action taken if the “EUT fail input” (on system Interface port) is activated.

When the button is set to “Stop” and the “EUT fail input” is activated, the test stops. The test can be restarted by pressing the Start key on the front panel.

When the button is set to “Pause” and the “EUT fail input” is activated, the test goes into pause mode. The test can be continued by pressing the “Start” key

on the front panel. When the button is set to “CONT.”, the test will continue even if the EUT fail.

EUT Power Supply at EUT Fail Input

Touch the “EUT Power Supply at EUT Fail Input” button (not shown on example) to specify the action taken if an “EUT fail signal” is generated.

When the button is set to “On”, EUT power stays ON after the “EUT fail Input” is activated.

When the button is set to “Off”, EUT power shuts down when the “EUT fail Input” is activated.

EXIT

Touch the “Exit” button to return to the system window without saving changes.

EUT ON/OFF

This button displays the EUT input power status.

OK

Touch the “Ok” button to save changes and return to the system window.

7.3 Updating SUI software via the SD-card

To change the SUI software, first switch off the generator and remove all power cords and cables. Open the top housing cover of the generator as described below.



WARNING - Before opening the generator make sure that it is turned OFF and disconnected from all power and signal cables!

To open the NSG 3040, the user must first remove the sides panels. Each side panel has 4 snap fixtures which will separate when outward pressure is applied.

1. Pull outward on the indentation in the front of the side panel. A blunt tool which will not scratch the paint on the panel may be used.
2. Pull outward to separate the panel from the snap fixtures.
3. Remove the upper screws on both sides of the generator cover.
4. Remove the NSG 3040 cover. The SD-card slot is located at the right front of the generator, in back of the front panel.
5. Press the SD-card to release it. Remove the card from the slot. To install a new SD-card, proceed to step 7.
6. To download new software from a PC to the SD card, insert the card in the SD port of the PC and copy the software to the SD card. The file name must remain SUI3000AP.EXE. Remove the SD card from the PC.
7. Insert the SD-card in the NSG 3040. Follow steps 1 - 4 in reverse to replace the generator cover and side panels.
8. Restart the NSG 3040. The new software version will boot automatically and may be verified in the equipment detail window (see section 7.7.1).

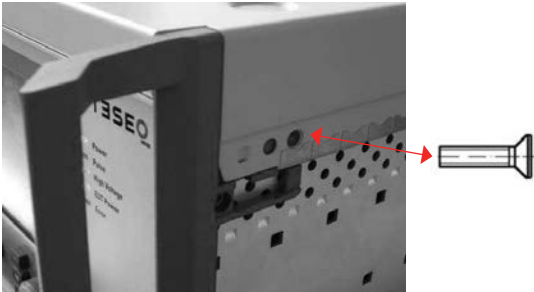

Removing the NSG 3040 side panels and cover

The SD-card is placed on the upper right position.



NSG 3040 SD-card slot

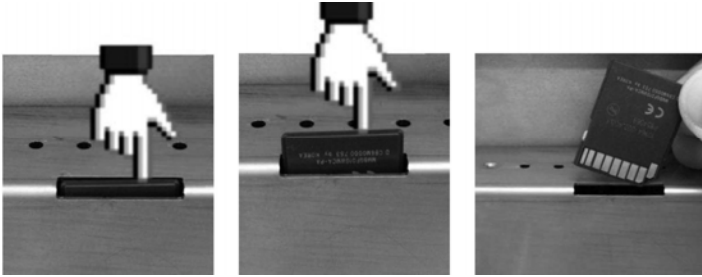

Removing the SD-card

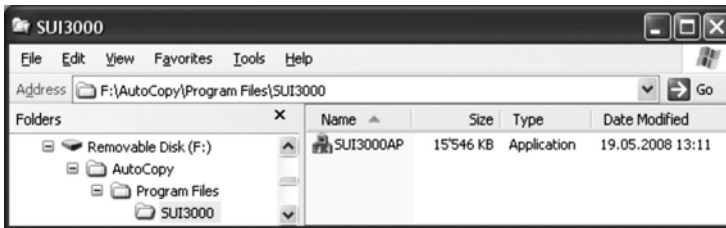

Windows explorer displaying the SUI program filename (SUI3000AP.EXE) on the SD-card (removable disk (F:))



NOTE: Do not change the SUI program filename.

8 PARAMETER SETTING WINDOW



The main menu displays a button for every type of test that can be performed by the NSG 3040. Buttons for tests that are not available on the system as configured are greyed out.

The user can set parameters for available tests and create new tests in the test parameter window.

The next figure shows the test parameter window for burst tests. While the input fields differ for each type of test, the red side bar and bottom bar remain the same.

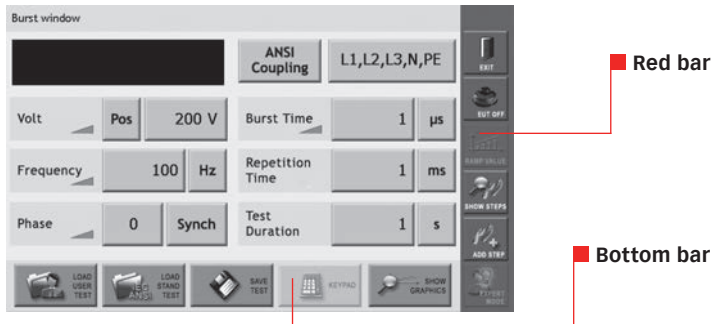

Example of the burst test window, showing the red bar and bottom bar.

8.1 The red menu bar

EXIT

Touch the "Exit" button to return to the system window without saving settings.

EUT OFF/EUT ON

Touch the “EUT Off/EUT On” button to switch EUT power off or on.

Note: The EUT power function can work only in combination with an automated accessory, such as a variac, step transformer or automated CDN.

RAMP VALUE

The “Ramp value” button is active only if a rampable parameter in the test window is selected. All rampable parameters are identified by a small gray ramp icon. This icon will turn red when a parameter is ramped.

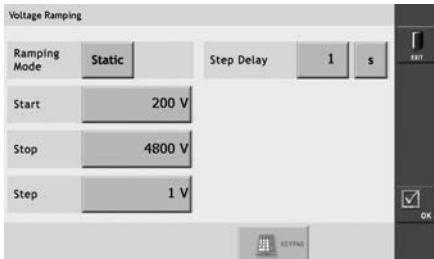

Ramping window for voltage parameter

- Ramping mode

Touch the “Ramping mode” button (“Static” in the example) to change the ramping mode from static to linear. In linear mode the user can set Start, Stop and Step values.
- Start

Touch the “Start” button (“200 V” in the example). A red frame is displayed around the field. Enter the Start value using either the wheel or the keypad.
- Stop

Touch the “Stop” button (“4800 V” in the example). A red frame is displayed around the field. Enter the Stop value using either the wheel or the keypad.
- Step

Touch the “Step” button (“1 V” in the example). A red frame is displayed around the field. Enter the Step value using either the wheel or the keypad.

- **Step delay** Touch the “Step delay” button (“1” in the example). A red frame is displayed around the field. Enter the Step Delay value using either the wheel or the keypad. Touch the “Unit” button (“s” in the example) to set the step delay unit. The step delay depends on pulses and the minimum repetition rates.

OK

Touch the “OK” button to save all settings and return to the test parameter window.

EXIT

Touch the “Exit” button to return to the test parameter window without saving settings.

SHOW STEPS

Touch the “Show Steps” button to view, change the order of, or delete individual test steps. The show step window displays individual test steps in the order that they will be executed.

■ **UP/DOWN**

Use the “UP” and “DOWN” arrows on the right side of the Show Step window to change the test step order. Touch a line number to select a step. A red frame is displayed around the selected step. Touch the “UP” button to move the step up in the list. Touch the “DOWN” button to move the step down in the list.

■ **DEL**

Touch a line number to select a step. A red frame is displayed around the selected step. Touch the “DEL” button to delete the step.

■ **OK**

Touch the “OK” button to save all settings and return to the test parameter window.

■ **EXIT**

Touch the “Exit” button to return to the Test parameter window without saving settings.

ADD STEP

Multi-step tests can be programmed manually in the test parameters window using the "Add Step" button.

Touch the "Add Step" button create a new step with the values currently displayed in the Test parameters window. The user can program a maximum of 10 test steps.

When the first test step is programmed, "Test Step 1/X" is displayed in the upper right corner, and the step can no longer be changed from the Test parameters window.

To change a step, the user must first delete it using the "Show Step" button, then use "Add Step" to re-enter the step.

Refer to sections 8.3 - 8.9 for detailed information on setting parameters for specific types of tests.

EXPERT MODE

The "Expert Mode" button can be used only if "Expert Mode" is set to "On" in the System/General settings window (see section 7.3). The unique expert Mode is a fast and effective method to determine critical threshold values of a device under test (EUT).

Touch the "Expert Mode" button to manually adjust test parameters using the wheel while a test is in progress.

A selected test can be started. During run mode the changeable parameter can be touched, the value window is highlighted with a red frame, like the voltage frame shown in the examples above. The value can now be changed via wheel and by pressing again the "START" button, the value will be accepted and on the pulse output the new value is displayed.

■ “Expert Mode” in Burst/EFT Mode

For safety reasons the Expert Mode activation needs to be confirmed again when using Burst Mode in the Burst Parameters Screen.

Following parameters can be controlled using “Expert Mode”:

- Volt (please note, the voltage change is only possible if the polarity is set to Negative or Positive)
- Frequency
- Phase
- Burst time

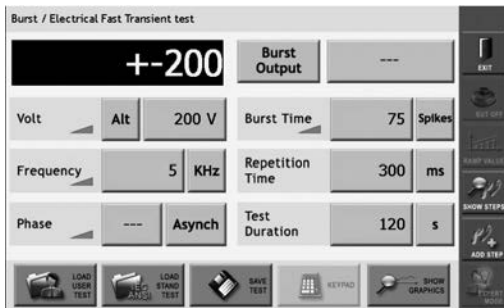

■ “Expert Mode” in SOW Mode

In SOW Mode only the voltage can be changed during a running test using “Expert Mode”.

8.2 The bottom bar

8.2.1 LOAD USER TEST

Touch the “Load User Test” button to display a list of all test files that have been created and saved by the user. Only files for the selected test type are displayed. The Figure below shows the load user test window with several burst tests displayed.

The user can scroll through the tests by touching the “UP” and “DOWN” arrows on the right side of the screen to scroll through the tests.

Touch the button to the left of the test name to select it. A red border is displayed around the selected test.

Touch the “OK” button to load the test and return to the test parameter window.

Touch the “Delete” button to delete a saved test. A window asking the user to confirm or cancel this action will be displayed. Touch “OK” to delete the file, or “Cancel” to cancel this action.

NOTE: Once a test has been deleted it cannot be restored.

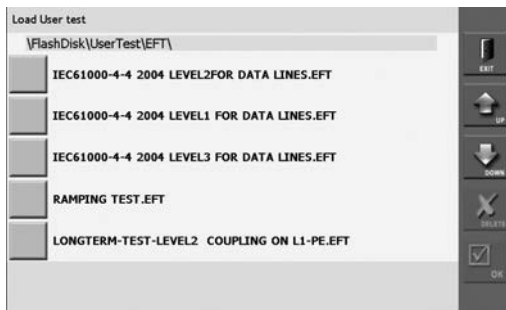

Load user test window

8.2.2 LOAD STANDARD TEST

The NSG 3040 includes all necessary test libraries corresponding to the latest editions of the IEC basic standards from the IEC/EN 61000-4-x series. They conform to many standard derivatives and product standards. Additionally some corresponding ANSI/IEEE standards as well as a selection of generic and product standards are available.

Depending on the selected pulse the appropriate IEC standard tests can be selected.

Following standard tests are included in the SUI:

Burst, IEC 61000-4-4

- 1-Phase power lines level 1 up to level 4, 5 kHz
- 1-Phase power lines level 1 up to level 4, 100 kHz
- 3-Phase power lines level 1 up to level 4, 5 kHz
- 3-Phase power lines level 1 up to level 4, 100 kHz
- Capacitive coupling clamp level 1 up to level 4, 5 kHz
- Capacitive coupling clamp level 1 up to level 4, 100 kHz

Combination wave (Surge), IEC 61000-4-5 [1.2/50 μ s & 8/20 μ s]

- 1-Phase power lines L-N coupling level 1 up to level 4
- 1-Phase power lines L-PE coupling level 1 up to level 4
- 1-Phase power lines N-PE coupling level 1 up to level 4
- 3-Phase power lines Lx-Lx coupling level 1 up to level 4
- 3-Phase power lines Lx-PE coupling level 1 up to level 4

- DC-Line L-N coupling level 1 up to level 4
- Unshielded unsymmetrical I/O lines level 1 up to level 4
- Unshielded symmetrical communication lines level 1 up to level 4

Power magnetic field, IEC 61000-4-8

- 50 HZ CF 9.8, level 1 up to level 4
- 60 HZ CF 9.8, level 1 up to level 4

Pulsed magnetic field, IEC 61000-4-9

- CF 0.98, level 3 up to level 5
- CF 3.4, level 3 up to level 5

Dips and Interrupts for AC power lines, IEC 61000-4-11

50 Hz, AC Power Lines, Class 2, Dips, 0%, 0.5 Cycle dips up to 25 Cycle

60 Hz, AC Power Lines, Class 2, Dips, 0%, 0.5 Cycle dips up to 30 Cycle

50 Hz, AC Power Lines, Class 3, Dips, 0%, 40%, 70%, 80%, 0.5 Cycle dips up to 250 Cycle

60 Hz, AC Power Lines, Class 3, Dips, 0%, 40%, 70%, 80%, 0.5 Cycle dips up to 300 Cycle

50 Hz, AC Power Lines, Class 2, Short interruption, 0%, 250 Cycle dips

50 Hz, AC Power Lines, Class 3, Short interruption, 0%, 250 Cycle dips

60 Hz, AC Power Lines, Class 2, Short interruption, 0%, 300 Cycle dips

60 Hz, AC Power Lines, Class 3, Short interruption, 0%, 300 Cycle dips

50 Hz Voltage variations

60 Hz Voltage variations

Dips and Interrupts for DC lines, IEC 61000-4-29

DC Voltage Dips 40%, 0.01 s up to 1 s

DC Voltage Dips, 70%, 0.01 s up to 1 s

DC voltage interruption, 0%, 0.001 s up to 1 s

DC voltage variation, 80%, 0.1 s up to 10 s

DC voltage variation, 85%, 0.1 s up to 10 s

DC voltage variation, 120%, 0.1 s up to 10 s

Slow Damped Oscillatory Wave (SOW), IEC/EN 61000-4-18

1-Phase power lines L-N coupling, 100 kHz, level 1 up to level 3

1-Phase power lines L-N coupling, 1 MHz, level 1 up to level 3

1-Phase power lines L-PE coupling, 100 kHz, level 1 up to level 3_noteA

1-Phase power lines L-PE coupling, 1 MHz, level 1 up to level 3_noteA

1-Phase power lines LN-PE coupling, 100 kHz, level 1 up to level 3_noteA

1-Phase power lines LN-PE coupling, 1 MHz, level 1 up to level 3_noteA

1-Phase power lines N-PE coupling, 100 kHz, level 1 up to level 3_noteA

1-Phase power lines N-PE coupling, 1 MHz, level 1 up to level 3_noteA

ANSI/IEEE C37.90.1 (SOW)

- 1-Phase power lines L-N coupling, 1 MHz, 2500 V
- 1-Phase power lines L-PE coupling, 1 MHz, 2500 V
- 1-Phase power lines LN-PE coupling, 1 MHz, 2500 V
- 1-Phase power lines N-PE coupling, 1 MHz, 2500 V

IEC TS 61000-6-5 (SOW)

- 1-Phase power lines L-N coupling, 1 MHz, 500/1000/2500 V
- 1-Phase power lines L-PE coupling, 1 MHz, 500/1000/2500 V
- 1-Phase power lines LN-PE coupling, 1 MHz, 500/1000/2500 V
- 1-Phase power lines N-PE coupling, 1 MHz, 500/1000/2500 V

IEC 61850-3 (SOW)

- 1-Phase power lines L-N coupling, 1 MHz, 2500 V
- 1-Phase power lines L-PE coupling, 1 MHz, 2500 V
- 1-Phase power lines LN-PE coupling, 1 MHz, 2500 V
- 1-Phase power lines N-PE coupling, 1 MHz, 2500 V

IEC 60255-26 (formerly IEC 60255-22-1) (SOW)

- 1-Phase power lines L-N coupling, 1 MHz, 1000/2500 V
- 1-Phase power lines L-PE coupling, 1 MHz, 1000/2500 V
- 1-Phase power lines LN-PE coupling, 1 MHz, 1000/2500 V
- 1-Phase power lines N-PE coupling, 1 MHz, 1000/2500 V

IEC 62052-11 (SOW)

- 1-Phase power lines L-N coupling, 100 kHz/1 MHz, 1000 V
- 1-Phase power lines L-PE coupling, 100 kHz/1 MHz, 2500 V
- 1-Phase power lines LN-PE coupling, 100 kHz/1 MHz, 2500 V
- 1-Phase power lines N-PE coupling, 100 kHz/1 MHz, 2500 V

8.2.3 SAVE TEST

The “Save Test” button is used to save the current test to a file for later use.

Touch the “Save Test” button. A keyboard is displayed. Touch the individual keys to enter a file name in the black bar above the keyboard.

The “Delete” key will delete all text entered. The backspace button (<-->) will delete the last letter entered. Touch the “Enter” button to save the file under the name entered.

All letters and numbers, as well as hyphens, spaces and dots, can be used in file names. The maximum file name is 40 characters, including spaces.

The system automatically generates a file extension to identify the type of test. For example, all burst tests will be given the extension .EFT.

Touch the “Cancel” button to return to the test parameter window without saving the file.

8.2.4 KEYPAD

Touch the “Keypad” button to display a numeric keypad. The Keypad button is active only when the user has selected a parameter that requires a numeric entry.

Touch individual numbers to enter them, touch “C” to clear an entry, and touch “Enter” to enter the value in the field. After touching “Enter” the keypad will close.



Keypad

8.2.5 SHOW GRAPHICS

Touch the “Show Graphics” button to display waveforms, coupling diagrams and other graphical information for the selected test.

Touch the “More” button to view additional information.

Touch the “Back” button to view previous graphics.

Touch the “Exit” button to return to the Test parameters window.

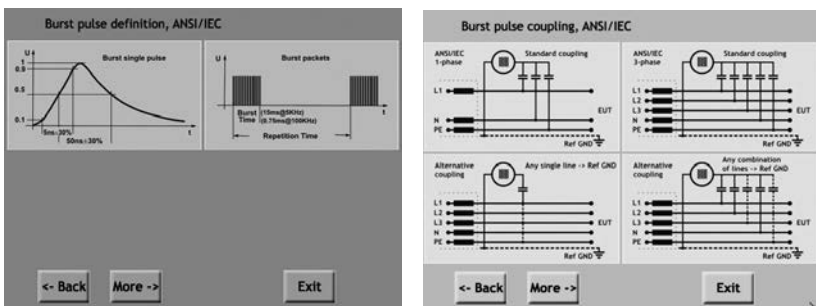

Example burst pulse graphs

8.3 Burst parameter setting

The generation of high voltage bursts and high frequency pulses is part of the EFT/burst package test required in the international standard EN/IEC 61000-4-4.

The test NSG 3040 generates bursts of interference that simulate the interference that is generated when inductively loaded switches are operated. With their very steep rising and falling edges, these interference pulses spread over a frequency spectrum of over 300 MHz and may occur wherever electrical currents are switched off in connection with motors, circuit breakers, relays, fluorescent lamps, etc. Therefore, nearly all the relevant standards concerning the testing of electronic equipment require the performance of burst tests.

8.3.1 Test configuration with power line coupling

In a power line coupling test, the NSG 3040 generates the interference signal, which is superimposed on the EUT power signal.

8.3.2 Test configuration with external coupling

In an externally coupled test, the interference signal is delivered through the NSG 3040's coaxial burst output connector (SHV-type) on the front panel and fed to an external coupling clamp. The signal is then applied to signal or data line cables.

The same SHV type connector may also be used for connection of a 3-phase CDN or for a CDN suitable for 1-phase >16 A and all other CDNs.



NOTE - A Teseq CAS 3025 calibration set must be used with a minimum 400 MHz digital oscilloscope to accurately verify the EFT pulse parameters.

Single pulse

Pulse burst

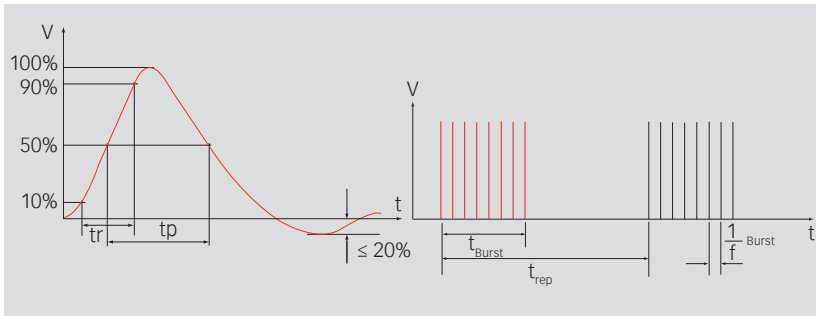

Burst wave shape and timing definitions

$$t_r = 5 \text{ ns} \pm 30\%$$

$$t_p = 50 \text{ ns} \pm 30\% \text{ into } 50 \Omega$$

$$t_p = 50 -15 \text{ ns}/+100 \text{ ns into } 1000 \Omega$$

8.3.3 Burst parameters window

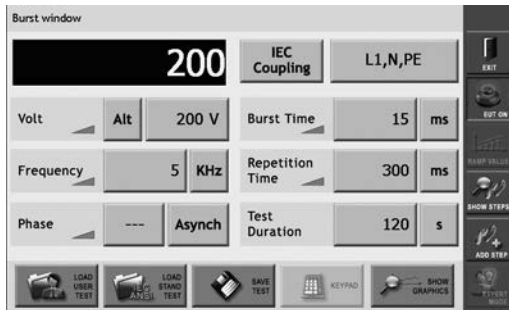

Burst parameter setting window

8.3.4 Voltage

Touch the "Polarity" button (ALT in the example) to select test polarity. Polarity values are: **positive (POS)**, **negative (NEG)**, or **alternating (ALT)**.

On odd pulse number there will be one pulse less in negative than in positive. Positive pulse will be first executed.

Touch the "Voltage" button (200 V in the example) to enter the test voltage. A red frame is displayed around the field. The voltage value may be entered using the wheel or the keypad.

8.3.5 Frequency

Touch the "Frequency" button (5 in the example) to set the test frequency. A red frame is displayed around the field. The frequency value may be entered using the wheel or the keypad.

Touch the units button (KHz in the example) to set the frequency unit. Frequency values are Hz and KHz.

8.3.6 Phase

Touch the Synch/Asynch button (Asynch in the example) to activate the synchronization of test pulses to the EUT mains frequency.

When this button is set to Asynch, the phase value button (--- in the example) will display '---'. When this button is set to Synch, the user must also set the phase value.

To set the phase value, touch the phase value button. A red frame is displayed around the field. The phase value may be entered using the wheel or the keypad.

The value is in degree units and may range from 0 to 359.

8.3.7 Coupling

Touch the "Coupling mode" button (IEC COUPLING in the example) to select **BURST OUTPUT, MANUAL CDN, ANSI COUPLING** or **IEC COUPLING**.

Burst output

Burst output must be selected if an external capacitive coupling clamp (e.g. CDN 3425) is connected to the NSG 3040.

Manual CDN

The factory setting for manual CDN is the same as for burst output.

IEC coupling

Touch the coupling line selection field (L1, N, PE in the example) to display the coupling selection window.

Touch the individual "high output coupling line" buttons (L, N, and PE in the example) to select an open or closed relay.

The "Low output" field (Ref. ground in the example) is always fixed.

Touch "OK" to enable the coupling selection and close the window.

Touch "Cancel" to close the window without saving the coupling selection.

Touch "Show Graphics" to display a graphical example of the coupling selection.

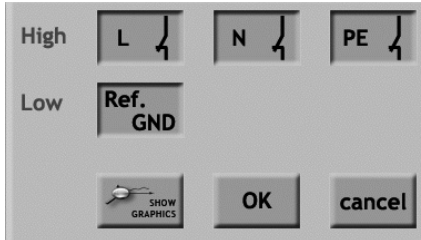

Coupling selection window

Note: Burst coupling is always to HF reference ground.

8.3.8 Burst time

Touch the "burst time" button (15 in the example) to set the burst time. A red frame is displayed around the field. The burst time may be entered using the wheel or the keypad.

Touch the "units" button (ms in the example) to set the time unit. Time units are **s**, **ms**, **µs** and **spikes**.

8.3.9 Repetition time

Touch the "Repetition time" button (300 in the example) to set the test repetition time. A red frame is displayed around the field. The repetition time may be entered using the wheel or the keypad.

Touch the "units" button (ms in the example) to set the time unit. Time units are **s** and **ms**.

Note: The repetition time must be shorter than the test duration.

8.3.10 Test duration

Touch the "Test Duration" button (120 in the example) to set the test duration time. A red frame is displayed around the field. The duration time may be entered using the wheel or the keypad.

Touch the "units" button (s in the example) to set the time unit. Time units are **s**, **min**, **h** and **cont (continuous)**.

8.3.11 Burst generator technical data

| Parameter | Value |
|------------------|---|
| Pulse amplitude: | ± 200 V to 4.8 kV (in 1 V steps) - open circuit ± 100 V to 2.4 kV (50 Ω matching system) |
| Voltage step: | 1 V/10 V/100 V |
| Polarity: | Positive/negative/alternate |
| Frequency: | Hz: 100 ... 99'999 kHz: 1 ... 1'000 |
| Phase: | Asynchronous, synchronous 0° to 359° (in 1° steps) |
| Coupling: | ANSI/IEC/external/manual |
| Burst time: | µs: 1 ... 99'999 ms: 1 ... 99'999 s: 1 ... 1'999 Spike: 1 ... 1000 |
| Repetition time: | ms: 1 ... 99'999 s: 1 ... 4'200 (70 min) |
| Test duration: | s: 1 ... 99'999 min: 1 ... 99'999 h: 1 ... 1'000 Continuous |

8.3.12 Derating

Some parameter combinations will not be accepted due to the power limitation of the HV power supply. The following error message will be displayed when an invalid combination of parameters is entered:



Invalid parameter error message

The following graphs show the relationship between the voltage, t_{rep} , t_{burst} and frequency, and show the range of possible parameter combinations that can be used in testing.

Each graph includes two voltage settings which are shown in different line thicknesses in relation to the t_{rep} values given for 20, 10, 5, 2, 1, 0.5, 0.2 and 0.1 ms. The appropriate t_{rep} value (bold t_{rep} for the bold line) are labeled on the border of the graph. Combinations of values that are below the line are allowed.

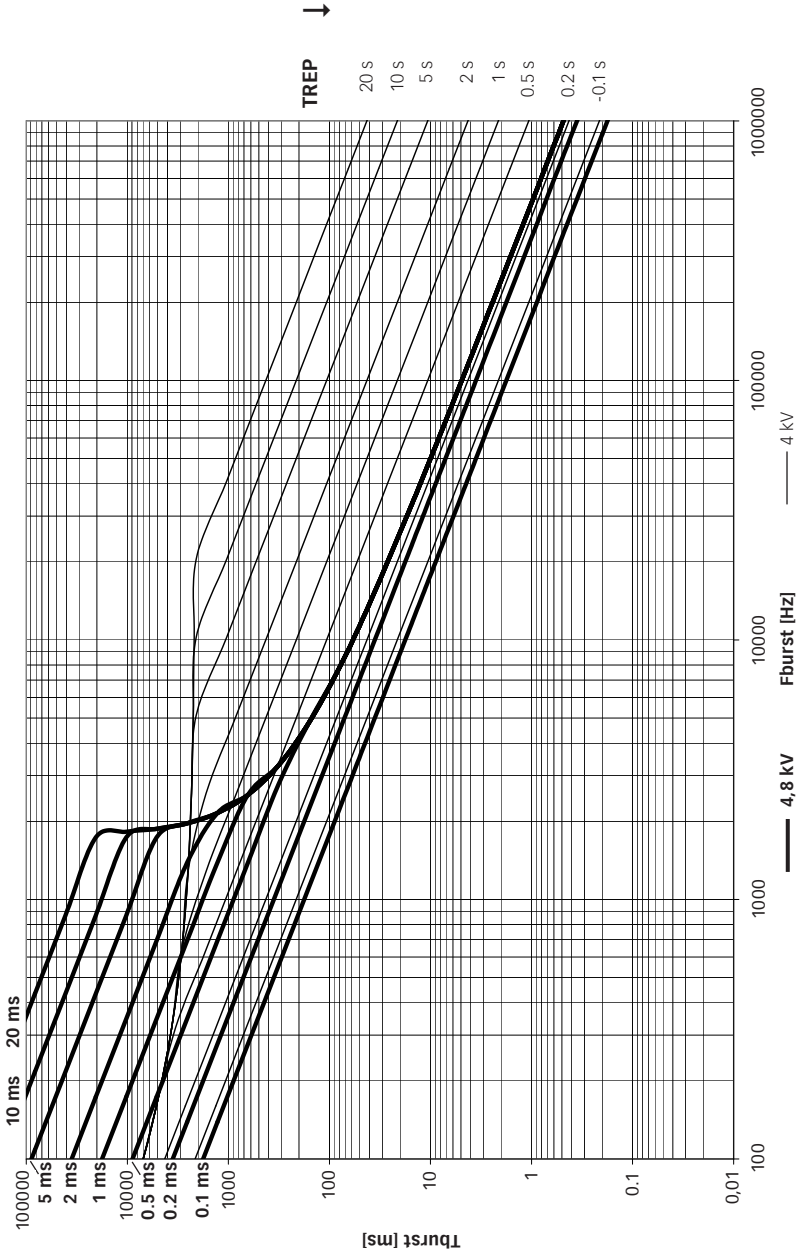

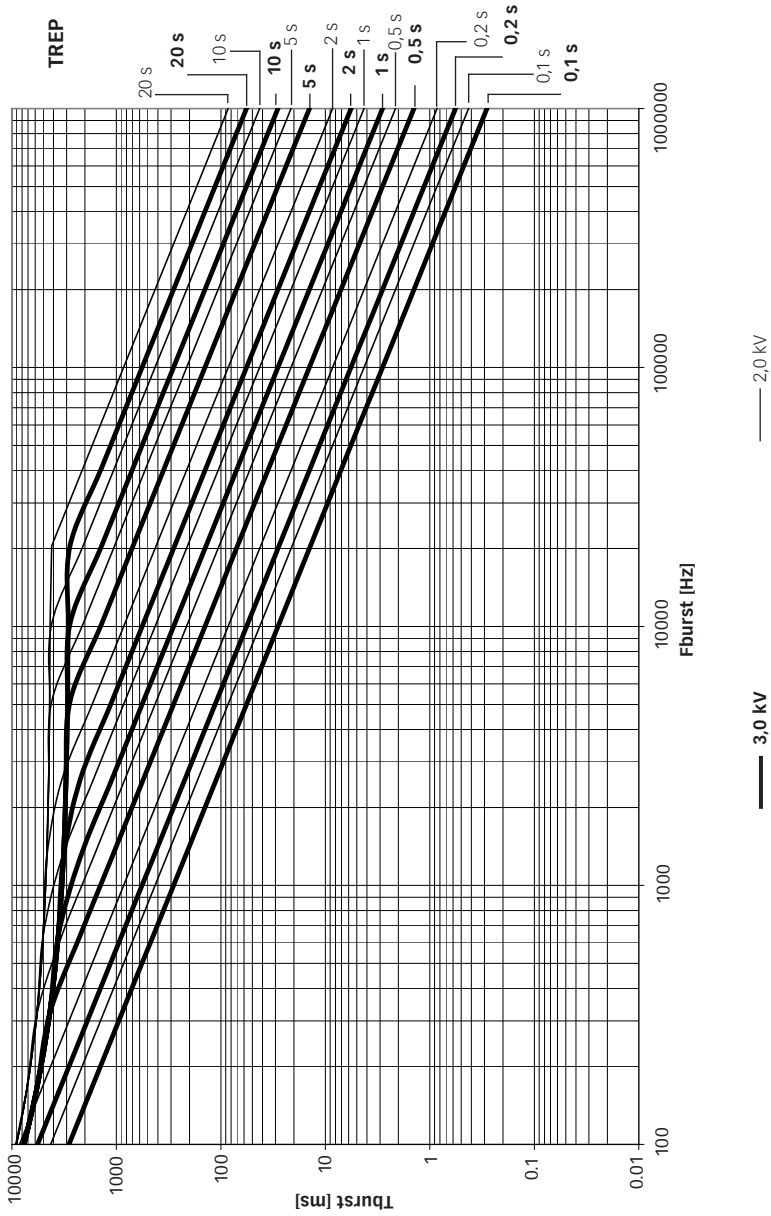

↓

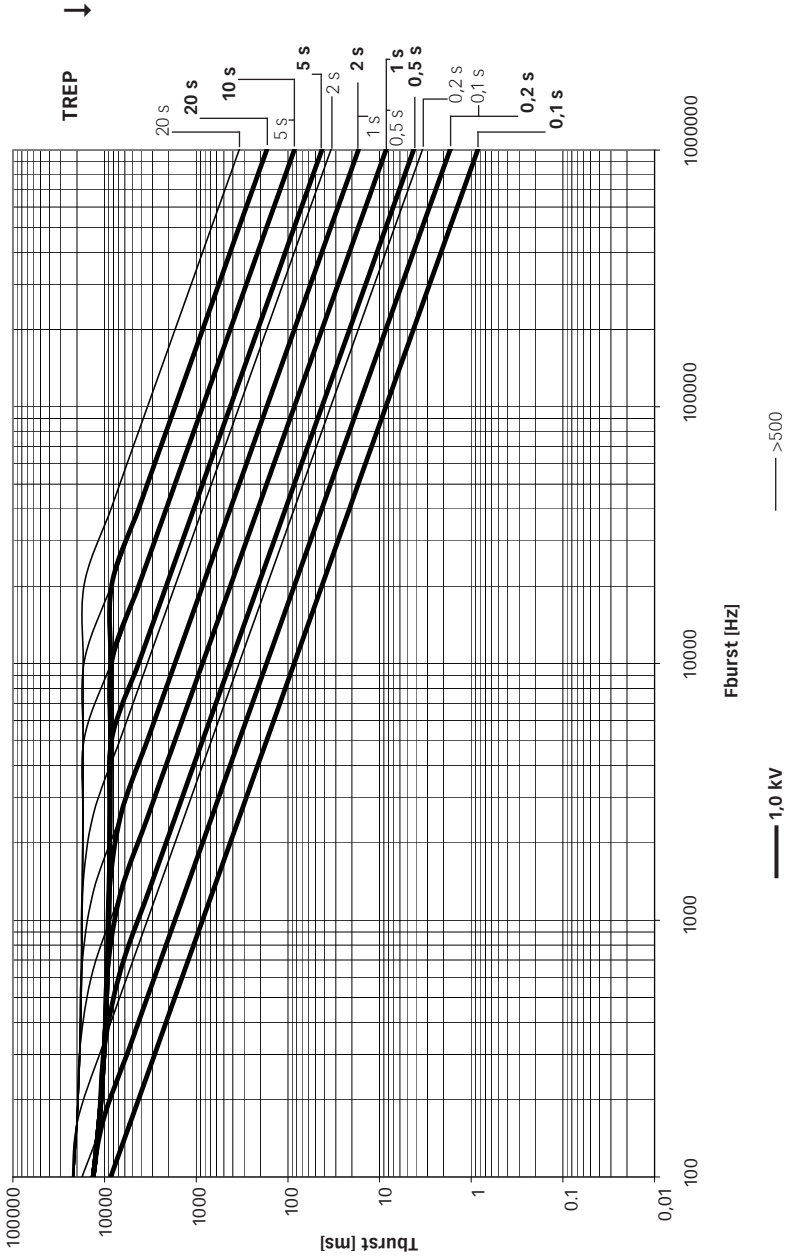

8.4 Combination wave (Surge) parameter setting

The surge test generates high voltage pulses as specified in the international standards EN/IEC 61000-4-5.

8.4.1 Test configuration for power line coupling

Test pulses are injected directly into the EUT power supply lines as they pass through the mains CDN's. The EUT obtains its power from the EUT power outlet on the front panel of the CDN where the mains voltage has the interference signal superimposed on it.

8.4.2 Test configuration for external coupling

In this mode, the interference pulses are switched to the surge Hi and Lo output sockets on the front panel, to which an external data line signal coupler can be connected. By using such an external signal coupler it is possible to superimpose the interference signal, as specified in the standards, on communication cables and other kinds of data lines.

The same coaxial HV output sockets may also be used for connection to all other CDNs.

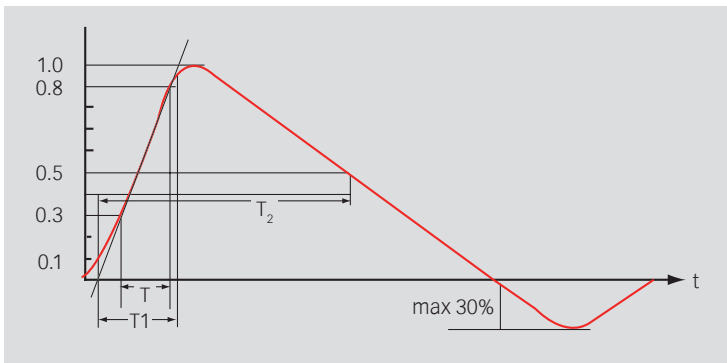

Front time $T_1 = 1.67 \times T = 1.2 \mu\text{s} \pm 30\%$

Time to half value $T_2 = 50 \mu\text{s} \pm 20\%$

Wave shape of open circuit voltage (1.2/50 μs), wave shape definition according to IEC/EN 61000-4-5.

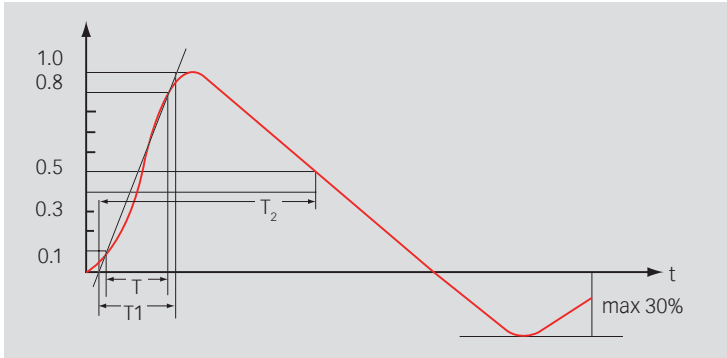

Front time $T_1 = 1.25 \times T = 8 \mu\text{s} \pm 20\%$

Time to half value: $T_2 = 20 \mu\text{s} \pm 20\%$

Wave shape of short circuit current (8/20 μs), wave shape definition according to IEC/EN 61000-4-5.



WARNING - Using improper equipment when measuring surge pulses can result in personal injury or equipment damage.

NOTE - Teseq recommends using a Teseq MD 200 or MD 200 A differential probe in combination with a Teseq INA 3236 Fischer-to-banana adapter for surge pulse verification.

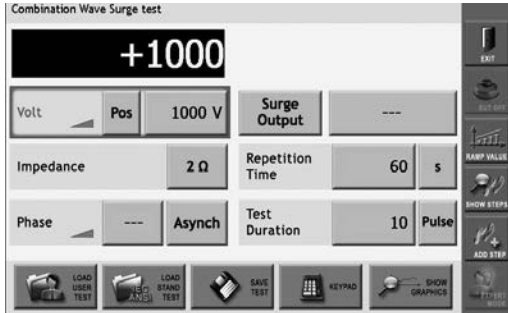

CW Parameter window

8.4.3 Voltage

Touch the “polarity” button (ALT in the example) to select test polarity. Polarity values are: **positive (POS)**, **negative (NEG)**, or **alternating (ALT)**.

On odd pulse number there will be one pulse less in negative than in positive. Positive pulse will be first executed.

Touch the “voltage” button (200 V in the example) to enter the test voltage. A red frame is displayed around the field. The voltage value may be entered using the wheel or the keypad.

8.4.4 Impedance

Touch the “impedance” button (2 ohms in the example), it will repetitively change between 2 and 12 Ω.

8.4.5 Phase

Touch the “Synch/Asynch” button (Asynch in the example) to activate the synchronization of test pulses to the EUT mains frequency.

When this button is set to Asynch, the “phase value” button (--- in the example) will display ‘---’. When this button is set to Synch, the user must also set the phase value.

To set the phase value, touch the “phase value” button. A red frame is displayed around the field. The phase value may be entered using the wheel or the keypad.

The value is in degree units and may range from 0 to 359. Synch mode is only available if the EUT power is switched on.

8.4.6 Coupling

Touch the “coupling mode” button to select **SURGE OUTPUT, MANUAL CDN** or **IEC COUPLING**.

Surge output

Select **SURGE OUTPUT** when a pulse is to be applied directly to the EUT; for example, in component testing of non-powered EUTs.

Manual CDN

This setting will compensate the loss of an external manual CDN such as the CDN 3083 or CDN 117. The internal impedance will be reduced by 0.37 Ω .

IEC coupling

When IEC coupling is selected the window in figure below displayed.

Touch the individual “High” and “Low output coupling” buttons (L, N, and PE in the example), to select an open or closed relay.

Touch “OK” to enable the coupling selection and close the window.

Touch “Cancel” to close the window without saving the coupling selection.

Touch “Show Graphics” to display a graphical example of the coupling selection.



IEC coupling selection window

8.4.7 Repetition time

Touch the “Repetition time” button (60 s in the example) to set the test repetition time. A red frame is displayed around the field. The repetition time may be entered using the wheel or the keypad.

Touch the “units” button (s in the example) to set the time unit. Time units are **s** and **min**.

8.4.8 Test duration

Touch the “Test duration” button (10 in the example) to set the test duration time. A red frame is displayed around the field. The duration time may be entered using the wheel or the keypad.

Touch the “units” button (pulse in the example) to set the unit. Unit values are pulse and cont (continuous).

8.4.9 Surge generator technical data

| Parameter | Value |
|--------------------------------|--|
| Pulse voltage (open circuit): | ± 200 V to 4.4 kV (in 1 V steps) |
| Pulse current (short circuit): | ± 100 A to 2.2 kA |
| Impedance: | 2/12 Ω |
| Polarity: | Positive/negative/alternate |
| Phase synchronization: | Asynchronous, synchronous 0° to 359° (in 1° steps) |

| | |
|-------------------|---|
| Coupling: | EC/external/manual |
| Pulse repetition: | 10* 600 s (in 1 sec steps) 1 10 min. |
| Test duration: | 1 to 9999 pulses Continuous |

* Repetition rate depends on voltage:

| | |
|----------------|------------------------|
| 200 to 4400 V | = 10 s repetition time |
| 4401 to 6600 V | = 20 s repetition time |

8.5 Dips, interrupts and variations

Dips, interrupts and variations tests are in line with the specifications of IEC 61000-4-11.

The EUT supply voltage (Input La), gets switched off shortly via a semiconductor switch, in order to generate short supply interrupts.

A second switch is available in the generator, with a second input channel (Input Lb) where a variable supply can be connected. This second switch works in opposition with the first one, so always one of the 2 switches is closed when the other one is open. Generally a step transformer or a variac is used as second supply, powered by the same supply than Input La, in order to have phase synchronisation of the 2 input sources. This setup allows "dips", which are short voltage variations from one supply voltage level (provided through generator Input La), to another voltage level (provided through generator Input Lb).

EUTs with "universal" supply voltage ranges (ex: 85 to 245 VAC) need to be tested for both extremes of supply. For this application Teseq offers a double variac VAR 3005-D16, which allows to provide the variable voltage required for EUT powering, as well as the variable voltage of the dip, this in one box, and powered from a single mains.

The use of a motorised variac as VAR 3005 also allows running variation tests, which are slower changes in EUT supply voltage.

Using DC supplies instead of AC supplies allows to test DC powered EUTs on a similar way. This is in line with the specifications of IEC 61000-4-29

8.5.1 Examples of dips & interrupts

a) Voltage dip of 30%

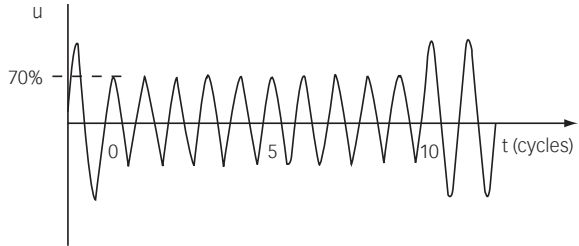

b) Voltage dip of 60%

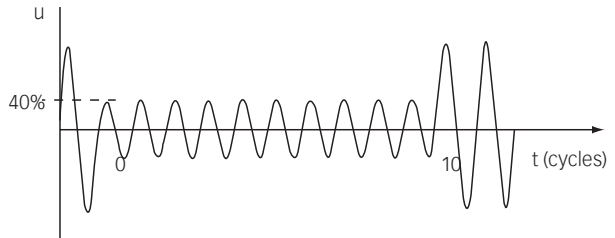

c) Voltage dip of 100%



8.5.2 Dips and interrupts generator

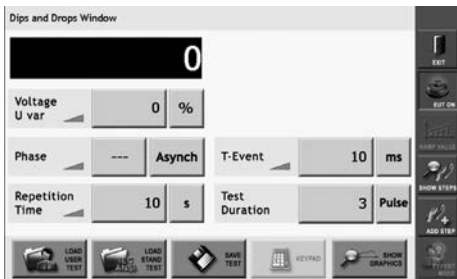

Dips and interrupts window

8.5.3 Voltage U Var

If no automatic variac or automatic transformer is connected, then the voltage dip or interrupt will always occur to 0%. Touching the units repetitively it will change from % to **Volts**.

If an automatic variac or automatic transformer is connected, then the field "Voltage Uvar" enables to set the dip voltage level.

If a manual voltage source is connected, then the dips/interrupts level will follow the manually set voltage at the EUT input, nevertheless this field will be inactive.

8.5.4 Phase

Touching the "Phase" field, it will come up with a red frame to indicate the selected parameter is ready for change. The value can be modified either with the red wheel or using the keypad. Touching the "**Synch/Asynch**" button it will change repetitively. In synch mode the **angle** can be modified either with the red wheel or using the keypad. Synch mode is only available along with a automated CDN and if the EUT power (AC) is switched on.

8.5.5 Repetition time

Touching the "Repetition Time" field, it will come up with a red frame to indicate the selected parameter being ready for change. The value can be modified either with the red wheel or by using the keypad.

Touching the units repetitively will change from **s, min, cycle, µs** to **ms**.

8.5.6 T-Event

Touching the "T-Event" field, it will come up with a red frame to indicate the selected parameter being ready for change. The value can be modified either with the red wheel or using the keypad.

Touching the units repetitively will change from **ms, s, cycle, 1/10 cycle** or **µs**.

8.5.7 Test duration

Touching the "Test Duration" field, it will come up with a red frame to indicate the selected parameter being ready for change. The value can be modified either with the red wheel or using the keypad.

Touching the units repetitively will change from **Pulse, Continuous, s** to **min**.

8.5.8 Dips & interrupts technical data

| Parameter | Value |
|---------------------------------|---|
| Dips & Interrupts: | From EUT voltage input to 0 V; 0% |
| Uvar with optional variac: | up to 265 V up to 115% of U_{in} 16 A max. $\pm 10\%$ |
| Uvar step transformer: | 0%, 40%, 70%, 80% |
| Peak inrush current capability: | > 500 A (at 230 V) |
| Switching times: | 1 to 5 μs (100 Ω load) |
| Phase phase synchronization: | Asynchronous, synchronous 0° to 359° (in 1° steps) |
| Time rep repetition time: | μs : 40 ... 99'999 ms: 1 ... 99'999 s: 1 ... 1'999 min: 1 ... 35 cycle: 1 ... 99'999 |
| Event time (T-Event): | μs : 20 ... 99'999 ms: 1 ... 99'999 s: 1 ... 1'999 cycle: 1 ... 300 $\frac{1}{10}$ cycle: 1 ... 3000 |
| Test duration: | s: 1 ... 99'999 min: 1 ... 70'000 pulse: 1 ... 99'999 Continuous |

8.5.9 Variation test technical data

| Parameter | Value |
|----------------------------|---|
| Uvar with optional variac: | up to 265 V (in 1 V steps) up to 115% of U_{in} (in 1% steps) |
| Phase synchronization: | asynchronous, synchronous, 0° to 359° (in 1° steps) |
| Repetition time: | 1000 ms to 35 min. 1 to 99'999 cycles |

| | |
|-----------------------------|---|
| Decreasing time Td: | ms: 1 ... 5000 s: 1 ... 5 cycle: 1 ... 250 cycles for 50 Hz 1 ... 300 cycles for 60 Hz Abrupt |
| Time at reduced voltage Ts: | ms: 1 ... 10000 s: 1 ... 10 cycle: 1 ... 250 cycles for 50 Hz 1 ... 300 cycles for 60 Hz |
| Increasing time Ti: | ms: 1 ... 5000 s: 1 ... 5 cycle: 1 ... 250 cycles for 50 Hz 1 ... 300 cycles for 60 Hz |
| Test duration: | s: 1 ... 99'999 min: 1 ... 70'000 pulse: 1 ... 99'999 Continuous |

Automatic accessories for power quality test

All automated standard accessories for PQT test provide a convenient means of reducing the incoming supply voltage.

Once detected, the functions are available in the user interface software. It's fully automatic controlled, driven from NSG 3040.

With the automatic step transformer INA 6502 the Uvar settings 0% – 40% – 70% – 80% will appear.

Connecting the single variac VAR 3005-S16 (or VAR 6501) the settings of Uvar will be possible in volts or % of U_{in} . Therefore U_{in} needs to be set first in the "General" settings menu. U_{in} in this case is the actual input voltage of the single variac.

When using the double variac VAR 3005-D16 (or VAR 6502) it is important that U_{in} in the "General" setting gets set first before entering the variation screen. The value of U_{in} is variable with the double variac.



For proper operation of the plug and play detection mechanisms it is strongly recommended to power on first the accessory and then the NSG 3040 main frame.

Powering on the NSG 3040 main frame before the accessories may result in non-detection of accessories.

More information about variable voltage sources is available in section 14 "Accessories".

8.6 Power Frequency Magnetic Field testing (-4-8) parameter setting

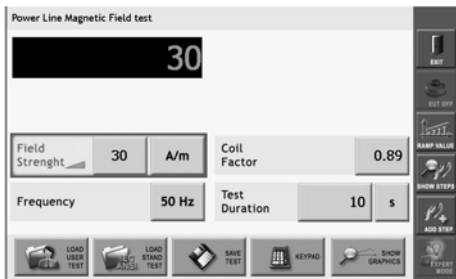

Power Frequency Magnetic Field test window

| Parameter | Value |
|-----------------|--|
| Field strength: | 1 to 100 A/m (in 1 A/m steps) |
| Frequency: | 50 Hz/60 Hz |
| Coil factor: | 0.01 to 99.99 |
| Test duration: | s: 1 ... 9'999 min: 1 ... 166 Continuous |

More information about variable voltage sources is available in section 14 "Accessories".

8.7 Pulsed Magnetic Field testing (-4-9) parameter setting

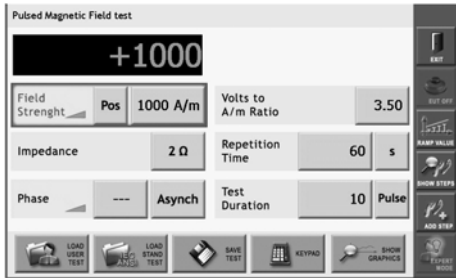

Pulsed Magnetic Field test window

| Parameter | Value |
|-------------------------------|---|
| Field: | 1 to 9999 A/m (in 1 A/m steps) |
| Polarity: | positive/negative/alternate |
| V to A/m ratio (Coil factor): | 0.35 to 99.99 |
| Impedance: | 2 Ω |
| Repetition time: | s: 10 ... 600 min: 1 ... 10 |
| Test duration: | 1 to 9'999 pulses Continuous |
| Phase synchronization: | asynchronous, synchronous 0° to 359° (in 1° steps) |

More information about variable voltage sources is available in section 14 "Accessories".

8.8 Slow Damped Oscillatory Wave test (-4-18) parameter setting

The slow damped oscillatory wave immunity test simulates switching of disconnectors in HV/MV open-air substations, and is particularly related to the switching of HV busbars, as well as to the background disturbance in industrial plants as specified in IEC/EN 61000-4-18 and ANSI C37.90.1.

The NSG 3040-SOW is not only able to perform the slow damped oscillatory wave immunity test according to both of these standards, but includes a wide range of over-testing capabilities like higher pulse voltage, higher pulse repetition rates and a selectable source impedance for tests closer to reality conditions.

8.8.1 Slow Damped Oscillatory Wave parameters window

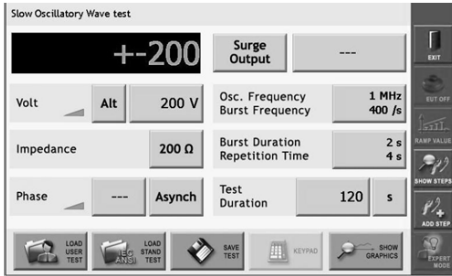

Slow Damped Oscillatory Wave test window

| Parameter | Value |
|------------------------------------|---|
| Coupling: | Surge output, Manual CDN, EUT Power Output |
| Pulse voltage: | ±200 to 4'400 V (in 1 V steps) |
| Polarity: | positive/negative/alternate |
| Oscillation frequency: | 100 kHz, 1 MHz |
| Burst frequency (repetition rate): | 100 kHz: 1/s to 120/s ¹⁾ , default 40/s 1 MHz: 1/s to 600/s ¹⁾ , default 400/s |
| Output impedance: | 200 Ω , 150 Ω |
| Burst duration: | s: 1 ... 100 pulse: 1 ... 9'999 Continuous |
| Repetition time: | ms: 2 ... 99'999 s: 1 ... 4'200 |
| Test duration: | s: 1 ... 99'999 min: 1 ... 60'000 h: 1 ... 1'000 Continuous |
| Phase synchronization: | asynchronous, synchronous 0° to 359° (in 1° steps) |

1) Burst frequency (= repetition rate) and (Burst duration ÷ Repetition time) are derated for voltage levels above 3.3 kV.

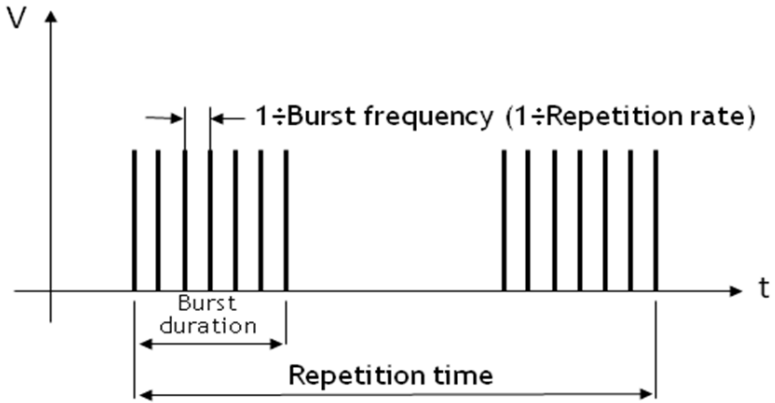
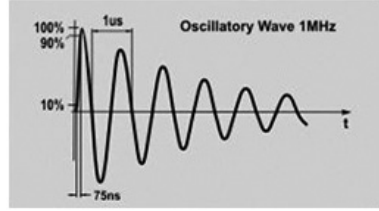
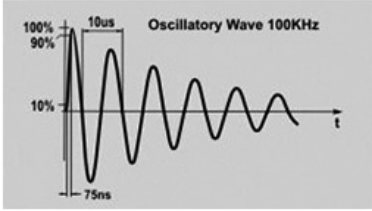

Explanation of "Burst frequency", "Burst duration" and "Repetition time" parameters

8.8.2 Coupling

Touch the “Coupling mode” button in the top row (“Surge output” in the example above) to select **Surge Output**, **Manual CDN** or **EUT Power Output**.

Surge Output

Surge Output must be selected if an external capacitive coupling clamp (e.g. CDN 3425) is connected to the NSG 3040-SOW.

Manual CDN

Manual CDN must be selected if an external manual coupling/decoupling device is connected to the NSG 3040-SOW. The factory setting for Manual CDN is the same as for Surge Output.

EUT Power Output

With EUT Power Output setting the Slow Damped Oscillatory pulses are directly applied on the EUT power output plug on the front panel of the NSG 3040-SOW.

Touch the coupling line selection field (- - - in the example) to display the coupling selection window.

Touch the individual “High output coupling line” buttons (L and N in the example) to select an open or closed relay.

Touch the individual “Low output coupling line” buttons (PE in the example) to select an open or closed relay.

Touch “OK” to enable the coupling selection and close the window.

Touch “Cancel” to close the window without saving the coupling selection.

Touch “Show Graphics” to display a graphical example of the coupling selection.



Coupling selection window

8.8.3 Output impedance

One of the unique features of the NSG 3040-SOW is the selectable output impedance (source impedance) of 200 Ω and 150 Ω . According to standard, 200 Ω is the fixed output impedance, while the 150 Ω value represents the actual impedance of cables (twisted pairs).

According to IEC 61000-4-18 Ed. 1.1: 2011, chapter 6.1.3 "Impedance value", the output impedance of the Slow oscillatory wave generator has been fixed to 200 Ω out of compatibility reason with other standards, "although the actual impedance of the cables (twisted pairs) is nearer to 150 Ω ".

Selecting 150 Ω enables manufacturer to test their equipment under conditions which reflect actual reality conditions, providing more accurate results and possibly a competitive advantage.

8.8.4 Timing parameters

To change the different timing parameters (Oscillation Frequency, Burst Frequency, Burst Duration, Repetition Time) touch the corresponding box with the preset value. An additional windows opens which enables to change the value within the limits given in the table above.

The new value may be entered by touching the parameter box and then by using the wheel in combination with the sensitivity keys (1, 10, 100 step) or the keypad.

Exit by clicking the "Ok" button to save your changes or "cancel" to exit without saving.

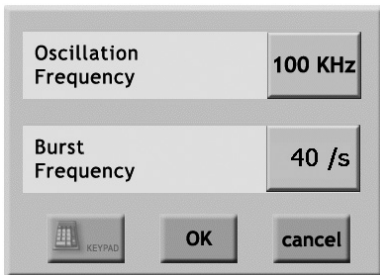

8.8.5 Test duration

The Test duration setting enables to set the total test time, i.e. the time period during which the SOW burst packages are sent out.

Changing the setting is easy - touch the Test duration value box on the parameter window (120 in the example) to set the test duration time. A red frame is displayed around the field. The duration time may be entered using the wheel or the keypad.

Touch the "units" button (s in the example) to set the time unit. Selectable time units are s, min, h and Cont (continuous).

8.8.6 Phase synchronization

Touch the Synch/Asynch button (Asynch in the example) to activate/deactivate the synchronization of test pulses to the EUT mains frequency.

When this button is set to Asynch, the phase value button (--- in the example) will display '---'. When this button is set to Synch, the user must also set the phase value.

To set the phase value, touch the phase value button. A red frame is displayed around the field. The phase value may be entered using the wheel or the keypad. The value is in degree units and may range from 0 to 359.

In Phase synchronization mode (Synch) the first pulse of a group will be synchronized with the set phase angle of the EUT mains frequency. The phase angle synchronization has priority over a possibly conflicting Repetition time setting.

8.8.7 Derating

Some parameter combinations will not be accepted due to the power limitation of pulse generating module. In case an invalid combination of parameters was entered an error message will be displayed when the test is started.

Following derating must be considered:

100 kHz Mode:

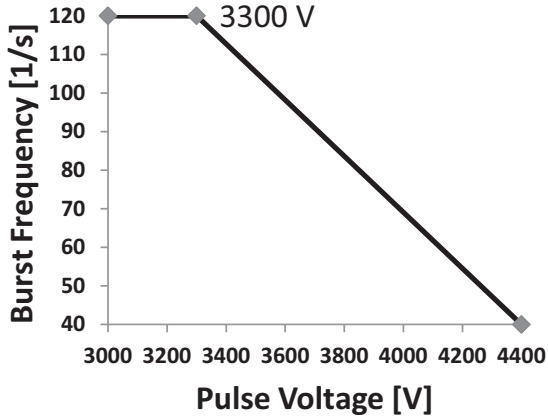

Burst frequency @ 100 kHz Pulse

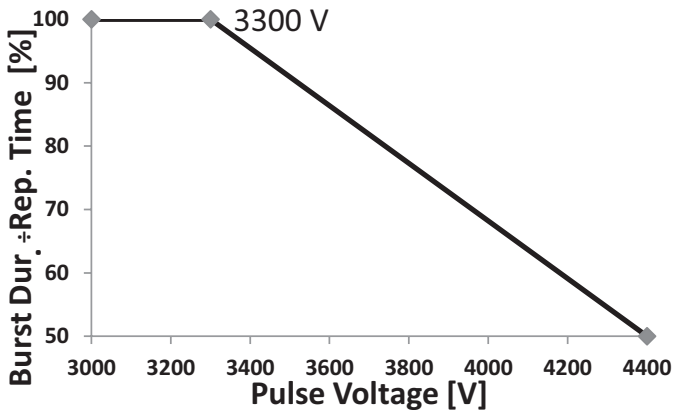

(Burst Duration ÷ Repetition Time) @ 100 kHz Pulse

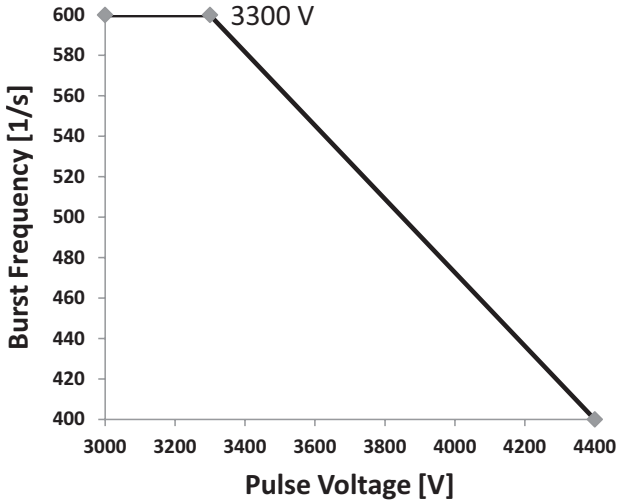

Burst frequency @ 1 MHz Pulse

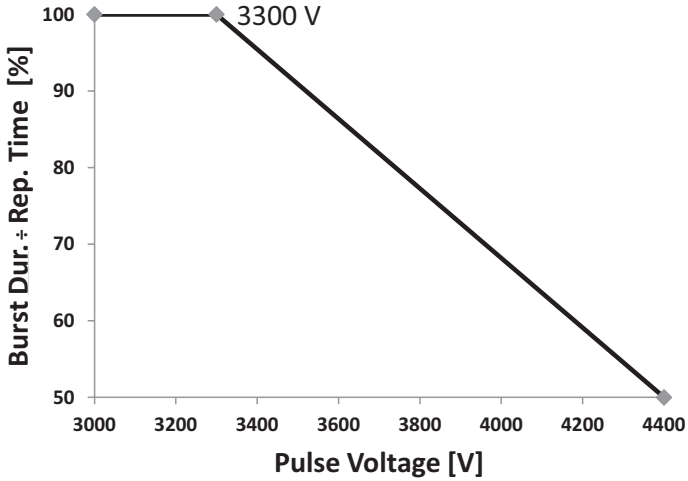

(Burst Duration ÷ Repetition Time) @ 1 MHz Pulse

9 DESCRIPTION OF THE 25 PIN D-SUB SIGNALS



Good EMC engineering practises should be applied when connecting signals to this port. As the whole system generates disturbances, in order to avoid auto disturbing, all wires connected to this port should be properly shielded, the shield of the cable not serving as signal return path, the shield to be connected via a large surface to the conductive shell of the Sub-D plug.

9.1 Interlock

Between Pin 5 (hi) and Pin 2, 8, 15, 20 (low).

This connection is an integral part of the interlock safety circuit. If a number of units are incorporated in a system, then these connections can be “daisy-chained” together to form a single safety circuit. If no external interlock circuit is required then the shorting connection must be made by using the terminator connector supplied. Otherwise pulse generation in the system will be inhibited.

A built in circuit breaker enables the EUT power supply also to be switched off, while the interlock function only blocks the generation of pulses or any other ongoing test resp.

The interlock is a safety function to ensures the following:

- The interlock forms a bus to which all instruments in a system are connected.

- The interlock feature can be connected to external safety devices (door contacts, test enclosure hoods, etc.).
- If any part of the interlock circuit is interrupted, all the generator modules are inhibited from producing or switching high voltages. Additionally the power supply to the EUT can be switched off too.
- Activation of this safety feature is reported to the master controller.
- The master controller is also notified when the interlock facility is reset.
- Once the interruption is over and the re-instatement of the interlock has been acknowledged, then power to the EUT is restored.

Activation of the interlock function is achieved without the help of microprocessors and software. This ensures that the safety feature is not affected or hindered in the event of a program crash.

9.2 Trigger to scope output signal

Between Pin 18 (hi) and Pin 2, 8, 15, 20 (low)

Inactive state: at 24 V, in the active state: < 2.4 V

Note: The trigger signal has generally a duration of approx. 50 μ s e.g. for surge testing. In case of bursts its width shall change according to the length of the event. During PQT testing (supply voltage variations) the width of the trigger signal shall change according to the duration of the voltage dip or interrupt.

9.3 Synchronization (Sync) signal: Output signal

Between pin 7 (hi) and pin 2, 8, 15, 20 (low)

Inactive state: at 24 V; in the active state: < 2.4 V

The sync signal consists of a level that goes low for each cycle of the mains frequency. The reference is the signal at the power supply input ("EUT supply IN"). The position (timewise) of the sync signal corresponds to the specified phase angle (converted into time, irrespective of the supply frequency).



The sync signal is only active while an AC test is in progress and Fsync is set to sync.

9.4 Pulse enable/next step input

Between pin 17 (hi) and pin 2, 8, 15, 20 (low)

Input open = inactive; input shorted = active

If this input is activated during a test run the test is halted (exactly the same as the pause function in the control software). The test will continue to run as soon as the input is made inactive again.

If the input is already active before a test is implemented then the test cannot start.

9.5 EUT fail input

Between pin 6 (hi) and pin 2, 8, 15, 20 (low)

Input open = inactive; input shorted = active

This connection serves as a control input that can be activated externally.

The EUT can activate this input if it is capable of reporting a disturbance effect caused during an EMC test. Such events are time/date stamped by the system and are stored together with the current test parameters for subsequent use in a test report if required.

9.6 EUT power off

Between pin 4 (hi) and pin 2, 8, 15, 20 (low)

Input open = Inactive, EUT power is controlled via front panel or WIN 3000 software

Input shorted = Active, in case EUT power is switched on, shorting this input will set EUT power to off

Notes:

1. Using this function only makes sense if an EUT power contactor is available somewhere in the system. EUT power contactors are available in VAR 3005, INA 6502, CDN 3061, CDN 3043, CDN 3063.

2. First the EUT power has to be switched ON via front panel or WIN 3000 software. This way allows dual drive, as the EUT power can then be switched OFF either from software control or from this external drive.

3. This signal is also used to drive the orange lamp of INA 3001 warning lamps.

9.7 High voltage active

Between pin 16 (Hi) and pin 2, 8, 15, 20 (low).

This function is activated for firmware revisions 2.30 and higher.

This output is to drive external warning lamps INA 3001. The HV on signal is working together with the high voltage LED located on the front panel.

Output high (24 V): High voltage is ON

Output low (0 V): High voltage is OFF

10 COUPLING NETWORK CDN 3041



The internal coupling network CDN 3041 is fully integrated in the NSG 3040 generator. It enables to couple the different pulses on a single phase EUT within the limits described below.

| Parameter | Value |
|-------------------------|--|
| Instrument supply: | 85...265 VAC |
| Decoupling attenuation: | Remanent pulse 15% max. Mains side crosstalk 15% max. |
| Standard-conform pulse: | 1.2/50 μ s up to 4.4 kV 8/20 μ s up to 2.2 kA |
| Mains decoupling: | 1.5 mH |
| Connections: | Pulse input(s) from generator Cable connector for EUT supply input and output Power inlet for CDN |
| EUT supply: | 1-phase (P/N/PE) |
| EUT VAC: | Up to 270 V rms *, 50/60 Hz (Phase - Neutral) |
| EUT VDC: | Up to 270 VDC |
| EUT current: | 1 x 16 A rms continuous over heat protected 1 x 25 A rms for 30 min |
| EFT (burst): | Standard coupling all lines to HF reference ground GND IEC/EN 61000-4-4 and ANSI (IEEE) C62.41 L, N, PE à GND |

* Below 24 VAC synchronisation not guaranteed, asynchronous mode only

| | |
|-------------------------|---|
| | Any lines and combination to ref GND: L à GND N à GND PE à GND L,N à GND L, PE à GND N,PE à GND |
| Combination wave pulse: | Line to line (2Ω) L à N/L à PE/N à PE IEC/EN 61000-4-5 Lines to ground (12Ω) L à PE/N à PE/L, N à PE |
| PQT: | IEC/EN 61000-4-11/-4-29 Dips & interrupts to phase L |

11 VARIOUS NSG 3040 VERSIONS



Thanks to a very flexible design concept, NSG 3040 is available in several configurations, in order to cover every need between a high end wide application coverage solution (multifunction generator) and dedicated single function instrument.

11.1 NSG 3040-IEC

NSG 3040-IEC is the high end configuration. It is fitted with pulse modules for dips, interrupts, combined wave surge and burst EFT. It includes a single phase 16 A CDN and the Teseq Standard User interface (SUI) featuring 7.2" colour touch display, start, pause and stop buttons and scalable rotary encoder.



11.2 NSG 3040 "a la carte" (customer specific)

The model presented above is available in almost any configuration, maintaining the fact that the mainframe is prepared for easy fit (plug and play) of any module, allowing easy upgrade.

11.2.1 Mainframe NSG 3040-MF

The NSG 3040-MF is wired, configured and tested for easy integration of all pulse modules. It includes following parts:

- 19" EMC Housing with front, rear panels, internal mechanics, wirings and plugs
- 7.2" color display
- Touch panel
- Rotary encoder
- Large Start, Stop and Pause buttons
- 5 status LEDs
- Universal power supply 85 – 265 V/ 50-60 Hz
- System master controller
- Single phase coupling network CDN 3041 270 V/16 A
- Fan with thermoregulated cooling controls
- LAN/ETHERNET Interface
- User manual
- S-FTP interface cable
- Mains supply cable and EUT supply cable
- Grounding strip

11.2.2 Mainframe for exclusive remote control NSG 3040-MF-ERC

ERC stands for exclusive remote control.

The NSG 3040-MF-ERC is similar to NSG 3040-MF but comes without user interface. It includes following parts:

- 19" EMC Housing with front , rear panels, internal mechanics, wirings and plugs
- 5 status LEDs
- Universal power supply 85 – 265 V/ 50-60 Hz
- System master controller
- Single phase coupling network 270 V/16 A
- Fan with thermoregulated cooling controls
- LAN/ETHERNET Interface
- User manual
- S-FTP interface cable
- Mains supply cable and EUT supply cable
- Grounding strip

11.2.3 Combined wave surge module CWM 3450

The CWM 3450 is a 4.4 kV Combined wave surge module and is compliant to EN/IEC 61000-4-5. It comes fully programmed and tested. A traceable calibration certificate is part of the delivery.

11.2.4 Dips and interrupts module PQM 3403

The PQM 3403 is a single phase 16 A dips and interrupts module and is compliant to EN/IEC 61000-4-11 and 29. It comes fully programmed and tested. A traceable calibration certificate is part of the delivery.

11.2.5 Electrical fast transient/burst module FTM 3425

The FTM 3425 is a 4.8 kV fast transients/ burst pulse module and is compliant to EN/IEC 61000-4-4. It comes fully programmed and tested. A traceable calibration certificate is part of the delivery.

11.3 NSG 3040-xxx-ERC series

ERC stands for Exclusive Remote Control.

Several models of the NSG 3040 series can be delivered in ERC configuration.

These special versions are made for the users who want to drive the instruments exclusively with a PC, using WIN 3000 software. In this case they might not need or even not want any User interface (SUI) on the instrument front panel.



Care has to be taken at first installation, as WIN 3000 needs proper installation on the drive PC. The setting of the interfaces needs to be done properly. For this consult the documents in PDF format available on the CD delivered with the instrument.



601-326B - NSG unit & WIN 3000 Installation - Quick installation guide english.pdf

Refer to sections 1, 2, 3, 4 and 5 of this document.

The factory setting of NSG 3040_ERC series is IP address 10.10.10.10, SubNet 255.0.0.0, Port 1025



WARNING - The factory setting of NSG 3040_ERC series is IP address 10.10.10.10, SubNet 255.0.0.0, Port 1025. Care has to be taken to remember the new settings if these get changed.

Forgotten IP settings can only be resetted in Teseq service centers. Therefore it is strongly recommended to leave the factory set IP and to install INA 3011 option on the user PC. The second IP address dedicated to the NSG 3040 control may be set to the fix IP address 10.10.10.11 (refer to quick installation guide) and so will not interfere with the PC network settings.



11.4 NSG 3040-xxx-EPO series

EPO stands for Exclusive Pulse Output.

These special versions are made for the users who use the instrument together with an external CDN from the CDN 3043, 3063 or 3083 model range, in which case they may not need the built-in single phase CDN 3041.



NSG 3040 EMC test system

11.5 NSG 3040-DDV

DDV stands for Dips, Drops (Interruptions) and Variations.

The NSG 3040-DDV is a single function generator made for Dips, Interruptions and Variations testing.



For interruptions and variations testing a variable voltage source is required. This is available from TESEQ in different versions as accessories:

- INA 6501 Manual Step transformer (0%, 40%, 70%, 80% levels)
- INA 6502 Automatic Step transformer (0%, 40%, 70%, 80% levels)
- VAR 3005-S16 Automatic variac
- VAR 3005-D16 Automatic double variac

See section 14 "Accessories" for more detailed information.



11.6 NSG 3040-SOW

SOW stands for Slow damped Oscillatory Wave.

The NSG 3040-SOW is a single function generator made for Slow Damped Oscillatory wave immunity testing according to IEC/EN 61000-4-18 (100 kHz & 1 MHz pulses) as well as to ANSI/IEEE C37.90.1 (1 MHz pulse).

The generator comes with an integrated single phase 270 VAC – 16 A CDN.



12 MAINTENANCE AND FUNCTION CHECK



12.1 General

Inside the test system there are no adjustable elements accessible to the user neither for calibration nor for maintenance purpose.

The housing of the test system must not be opened (except for SW update via SD-card). Should any maintenance or adjustment become necessary, the whole test system, together with an order or fault report, should be sent to a Teseq service center.

Maintenance by the user is restricted to cleaning the outer housing, performing a function check and verification of the pulse parameters.



The only exception concerns the exchange of modules or the upgrading of the system with new modules. In such cases the instructions accompanying the modules are to be strictly observed.

12.2 Cleaning

In general a moist cloth is sufficient for cleaning the outer housing, including the touch panel. If necessary add a small amount of a mild, non-foaming household cleanser.

No chemicals (acid, etc) should be used for cleaning purposes.

Before beginning to clean the test system ensure that it is switched off and the mains power cable is unplugged from the supply.

12.3 Function check



The safety measures described previously must be strictly observed while carrying out a function check.

As soon as the test system is switched on the Power-LED should light up. If this is not the case then please check the mains power connection to the test system as well as the fuses, voltage selector and any other cabling.

The instrument automatically carries out a diagnostic routine once it has been successfully switched on.

The generator cannot perform any test while the interlock circuit is open.

Pulse generation can be observed at the output connectors by means of an oscilloscope. This is a practical way to check that the system is functioning correctly but should never be used for reference or calibration purposes.



Do not connect the oscilloscope directly in order not to exceed its max. input voltage.

Teseq recommends the use of a HV differential probe type MD 200 or MD 200A along with the INA 6560 safety banana adapter as well as CAS 3025 and MD 300 or MD 310. (See paragraph: accessories).

12.4 Calibration

The combination of high voltages and high frequencies in a single pulse makes the calibration of EMC pulse generators particularly demanding and difficult. Teseq has one of the few accredited test laboratories in Europe that is in the position to undertake calibrations in this specialized field.

12.5 Warranty

Teseq grants a warranty of 2 years on this test system, effective from the date of purchase.

During this period, any defective components part will be repaired or replaced free of charge or, if necessary, the test system will be replaced by another of equivalent value. The decision regarding the method of reinstating the functional capability is at the sole discretion of Teseq.

Excluded from the warranty is damage or consequential damage caused through negligent operation or use as well as the replacement of parts subject to degradation.

The warranty is rendered invalid by any intervention on the part of the customer or a third party.

The faulty items have to be returned in their original packaging.

Teseq accept no responsibility for damage in transit.

13 DECLARATION OF CONFORMITY (CE)



TESEQ

Advanced Test Solutions for EMC

Teseq AG Nordstrasse 11F 4542 Luterbach Switzerland
T +41 32 681 40 40 F +41 32 681 40 48 www.teseq.com

Declaration of conformity



| | |
|--------------------|--|
| Manufacturer: | Teseq AG |
| Address: | Nordstrasse 11F, 4542 Luterbach, Switzerland |
| | declares that the following product |
| Product: | NSG 3040 |
| Options/Variants: | all |
| | conforms to the following Directives and Regulations |
| | EMC Directive 2004/108/EEC |
| | LVD Directive 2006/95/EEC |
| Generic standards: | EN 61326-1, 2013 |
| | EN 61326-2-1, 2013 |
| | EN 61010-1, 2010 |

The purpose of this instrument is the generation of defined interference signals for EMI immunity testing. Depending on the arrangement of the test rig, the configuration, the cabling and the properties of the EUT itself, a significant amount of electromagnetic radiation may result that could also affect other equipment and systems. The user himself or herself is ultimately responsible for the correct and controlled operation of the rig. In case of doubt, the tests should be carried out in a Faraday cage.

Place and Date: Luterbach, December 4th, 2013

Johannes Schmid
President



14.1 PC software

WIN3000

WIN 3000 remote software is a comprehensive program designed to create test libraries for the surge/burst, PQT, magnetic field and SOW tests that can be performed with Teseq's NSG 3000 generator series and its accessories.

WIN 3000 comes on a CD-ROM included in each NSG package or can be downloaded from the Teseq web site. Insert the CD-ROM and double click on setup.exe and follow the instructions on the screen.

The required communication cable (Crossover S-FTP cable) is part of the delivery.

All required documentation is available on the CD-ROM in PDF file format.

Consult first the document "Software Version History Vx.yz", to verify which FW and SUI version you may need to install for a proper function of the generator. WIN 3000 requires always the corresponding FW and SUI software.

The proper FW and SUI software are on the WIN 3000 installation disk or can be downloaded from the Teseq website.

WIN 3000 features a free 30 days licence of the professional version WIN 3000-SRD.

WIN 3000-SDR

The extension "SDR" stands for "Sequences" – "Dialogs" – "Reports"

WIN 3000-SDR is the professional version of PC Software for NSG 3xxx series. It features the basic settings possibilities of WIN 3000, inclusive parameter ramping, stepping, etc... and includes additionally:

- Test library covering most of basic and generic standards.
- Test sequencer
- Real time report facility in MS-Word
- Dialogs facility with the user

WIN 3000 and NSG 3000 series can run via a LAN connection.

A Win 3000 software licence is always valid for a specific NSG 3xxx instrument. Nevertheless the Software can be installed on a unlimited number of computers since the dongle is the NSG 3xxx instrument itself.

14.2 Coupling decoupling networks for multiple phases, higher currents and voltages

To allow testing of equipment rated for multiple phases, a wide range of Coupling - decoupling networks (CDNs) is available, in various configurations.

The CDN 3043 and 3063 series are available in multiple configurations and for different EUT currents and voltages.

These CDN series are fully automatic controlled, featuring plug and play technology - just connect them to the NSG 3040 and they will autodetect and auto-configure at system power up, available coupling possibilities will show up in respective test windows.

All CDN 3043 and 3063 series feature:

- Manual and programmable control of EUT power ON/OFF
- Input phase rotation detection

NSG 3040 EMC test system

- Thermal monitoring of internal backfilter chokes; in case the EUT current goes up, the integrated fans, which are still in standby mode and at low EUT currents, will speed up to improve cooling.
- In case of intentional or unintentional overloading, the CDN 3043 and 3063 series will automatically switch off EUT power, in order to protect itself (risk of fire)

Slow Damped Oscillatory Wave immunity testing of 3-Phase equipment needs a dedicated 3-Phase CDN. Please check your Teseq equipment supplier for availability.

14.2.1 CDN 3043 - 32 A series



NSG 3040 on top of CDN 3043

Technical specifications:

| | |
|------------------|---|
| Voltage ratings: | 280 VAC - phase to neutral or phase to ground |
| | 480 VAC - phase(s) to phase(s) |
| | up to 125 VDC - full current range |
| | up to 225 VDC - for max. 7 A |

Note: The DC current capability derating is given by the specification of the Circuit breaker used to switch EUT power ON and OFF. In case this internal EUT power ON/OFF function is not used the DC current full range can be used for up to 350 VDC.

| Name | Max. Current (A) | EFT Coupling | Combined wave surge coupling | Ring wave surge coupling |
|--------------|------------------|--------------|------------------------------|--------------------------|
| CDN 3043-B32 | 32 | x | | |
| CDN 3043-S32 | 32 | | x | x |
| CDN 3043-C32 | 32 | x | x | x |

14.2.2 CDN 3063 series - 63 A and 100 A series

Technical specifications:

| | |
|------------------|---|
| Voltage ratings: | 280 VAC - phase to neutral or phase to ground |
| | 480 VAC - phase(s) to phase(s) |
| | up to 125 VDC - full current range |
| | up to 225 VDC - for max. 7 A |

Note: The DC current capability derating is given by the specification of the Circuit breaker used to switch EUT power ON and OFF. In case this internal EUT power ON/OFF function is not used the DC current full range can be used for up to 350 VDC.

| Name | Max. Current (A) | EFT Coupling | Combined wave surge coupling | Ring wave surge coupling |
|---------------|------------------|--------------|------------------------------|--------------------------|
| CDN 3063-S63 | 63 | | x | x |
| CDN 3063-S100 | 100 | | x | x |

14.3 Variable voltage sources

14.3.1 Automatic Variacs

The automated variable transformer VAR 3005 series is a standard accessory for the Teseq NSG 3040 and NSG 3060/CDN 3061 instrumentation. In combination with a PQT module it provides a convenient means for reducing the incoming supply voltage by adjusting the incoming EUT supply voltage to arbitrary voltages.

The VAR 3005 comes in two different versions- as double source (VAR 3005-D16) where two supply sources are required to test equipment with universal power supplies and as single source (VAR 3005-S16), providing best price performance for applications where dual source is not required (mains supply of equipment under test is a fixed value).

The VAR 3005 option is required for power quality testing (PQT) dips and interrupts and is compliant with the latest revision of IEC/EN 61000-4-11 (2004) including the variation test. The VAR 3005 units are fully automatic controlled, driven from your NSG 3xxx generator, using the touch screen interface SUI or the WIN3000 software application. VAR 3005 is plug and play technology, it auto configures and avoids the user to set voltages out of range.

To prevent incorrect testing, the phase, neutral and earth line of EUT IN power line is observed and the 50/60 Hz frequency range will be set automatically. This feature helps especially in case where "cycle" parameter is set in a test procedure.

Once detected by the NSG 3xxx generator, all functions offered by the VAR 3005 are available including the possibility to switch EUT power on/off. EUT power can be switched ON and OFF manually per switch on the front panel, or remotely from the NSG 3xxx front panel or PC control software. EUT power can be switched off automatically at test end per sequencing program control. For safety reasons, EUT power will switch off automatically in case of overload.

The VAR 3005 can be connected either via a NSG 3040 with its internal coupling device or via the NSG 3060 in combination with a CDN 3061 and the built in power quality (PQT) module. The EUT input frequency will be detected automatically for a correct synchronisation of the PQT events.

Thanks to internal advanced microprocessor based control electronics the VAR 3005 features permanent self regulation, self check, mains voltage check, phase rotation check and informs the user or stops the test if the surrounding conditions are not given to guarantee a proper testing.

For further details please refer to the VAR 3005 User manual.



Available models:

VAR 3005-D16: Dual up to 265 VAC/16 A source

VAR 3005-S16: Single up to 265 VAC/16 A source



MAINS should be switched off during installation and interconnection.

- 1) Disconnect instrument power from the mains
- 2) Remove the 25-way Sub D plug on the rear of the NSG 3040
- 3) Connect the 25-way Sub D cable to the X2 plug of the VAR 3005
- 4) Connect the master controller 25-way output to the VAR 3005 X1 plug, using the system interface cable provided with the VAR 3005
- 5) Connect the VAR 3005-EUT power out to the NSG 3040 – EUT power input
- 6) Connect the VAR 3005-EUT power in to mains using the EUT power in cable delivered with NSG 3040



Because of the capacitors in the internal coupler of NSG 3040, earth leakage currents of up to 4 A can occur in the EUT power supply network. The test system must therefore be correctly earthed and be powered from a supply that is not protected by a residual current detector (RCD).

- 1) Switch on the VAR 3005 first
- 2) Switch on the NSG 3040
- 3) Switch on the EUT power (red switch) if power for the EUT is required.

HW Detection

The VAR 3005 is automatically detected by the NSG 3040 during the booting process. Its presence is visualised in the system settings screen.

| Equipment details | | | | |
|-------------------|----------------|------------|-------------------|-------------------|
| Module Name | FW Version | Serial No. | 1. Cal. Date | Last Cal. Date |
| CWM 3450 | 0002.11 | 172 | 22.2.2009 | 13.2.2009 |
| FTM 3425 | 0002.11 | 73 | 19.11.2010 | 19.11.2010 |
| VAR 3005- | 0002.11 | 1 | 15.9.2010 | 18.9.2010 |

Once a variac detected the function for voltage variations gets active. See functionality of variation tests below.



Operation

In case of a VAR 3005-D16 the **Uin** field in the window **System- General settings** appears. Here **Uin** (EUT supply voltage) can be set to any supply voltage within the specified range.

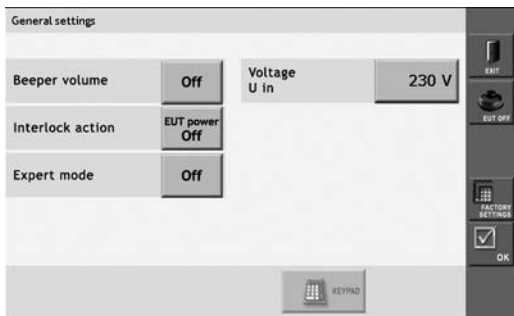

Dips and interrupts testing

The parameter Field **Voltage Uvar** gets active once a VAR 3005 has been detected by the software.

Uvar can be selected for one of the four available variable voltage levels: 0 - 40 - 70 - 80% .

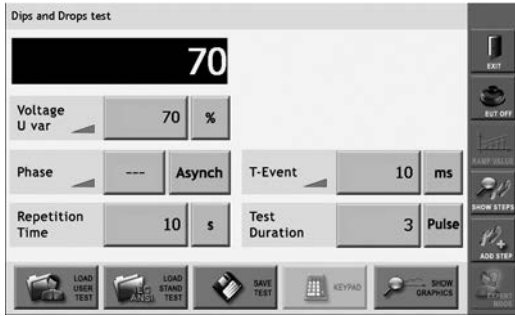

Voltage variations testing

Voltage variation tests are specified in chapter 5.2 of IEC 61000-4-11, and are available with NSG 3040 provided an automatic variac is detected by the system software.

Description of voltage variation test: extract of IEC 61000-4-11:

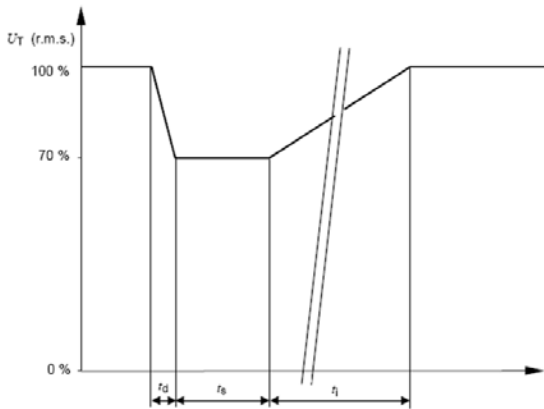

- Key**
- t_d Time for decreasing voltage
 - t_s Time for decreasing voltage
 - t_i Time for increasing voltage
 - t_s Time at reduced voltage

The respective test screen looks like what follows:

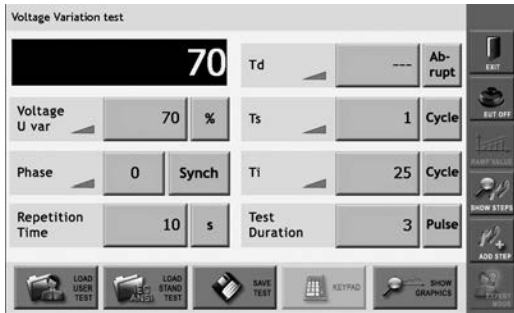

14.3.2 Manual step transformer: INA 6501

The step transformer type INA 6501 is a standard accessory for the Schaffner Modula 6100 instrumentation series. It provides a convenient means for reducing the incoming supply voltage by pre-set amounts. It is required for power quality testing (PQT) and is fully compliant with the latest revisions of IEC 61000-4-11:2004.



It is fitted with carrying handles as part of its overall good ergonomic design, which makes for ease of handling. Further, the unit may be used in any of three operating positions; laying or standing on a work bench, or for more permanent applications, it can be wall-mounted.



Care has to be taken in case of use in standing position, as the stability is limited. The cabling connecting INA 6501 to mains and Modula presents a risk of being unvoluntarily caught by the users which could cause the INA 6501 to fall down.

The few control elements are readily accessible on the front panel. An EUT power on/off switch with a power on indicator and a well-proportioned rotary switch to select the required voltage ensure easy and intuitive operation. The unit has been designed for use in rugged industrial environments. Professional quality connectors ensure user safety, additional system protection is provided by a 16 A fuse located in the front panel.

Thanks to the provision of an 80% voltage position and to the large overcurrent capabilities the step transformer is fully compliant with the latest requirements called for in IEC 61000-4-11: 2004 standard.

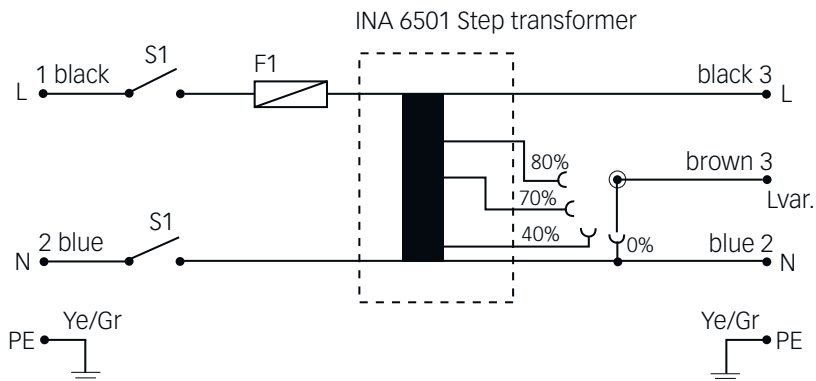

Technical specifications INA 6501

| | |
|---|---|
| Input voltage: | 0 to 250 VAC (not suited for DC voltages) |
| Output voltage: | 4 steps: 0, 40, 70, 80% |
| Accuracy: | ± 5% |
| Voltage change with load: | |
| 100% output , 0 to 16 A | less than 5% |
| 80% output, 0 to 20 A | less than 5% |
| 70% output, 0 to 23 A | less than 5 % |
| 40% output, 0 to 40 A | less than 5 % |
| Output current capability at 230 V input voltage: | 16 Arms at 100% output 20 Arms at 80% output 23 Arms at 70% output 40 Arms at 40% output |
| Voltage selection: | Front panel rotary switch |
| EUT power on/off function: | Front panel switch with on indicator |
| Fuse: | 16 A, slow blow |
| Connectors: | Harting type HAN3A |
| Power Supply: | Selectable 100-110 V, 220-240 V, 15 VA |
| Size: | 150 x 180 x 360 mm |
| Weight: | 12 kg approx. |
| Output cable length: | 2 meter |
| Input cable: | NSG 3000 standard cable to be used |

Installation - connection to NSG 3000 series

The equipment should be switched off during installation and inter-connection.

- 1) Connect INA 6501 - EUT power out to NSG 3040 - EUT power input
- 2) Connect INA 6501 - EUT power in to mains using EUT power in cable (delivered with NSG 3040)

NSG 3040 EMC test system



Because of the capacitors in the internal coupler of NSG 3040, earth leakage currents of up to 4 A can occur in the EUT power supply network. The test system must therefore be correctly earthed and be powered from a supply that is not protected by a residual current detector (RCD).

- 3) Switch on EUT power on INA 6501 (red switch) when power for the EUT is required
- 4) Switch on the NSG 3040
- 5) Select the required variable voltage using rotary switch on the INA 6501

Operation

The NSG 3040 operation software does not know that an external transformer is connected. The user interface software in the dips and interrupts test will always show **External** in the field for **Voltage U var**.

It is up to the user to make sure that the right voltages are set on the manual external transformer.

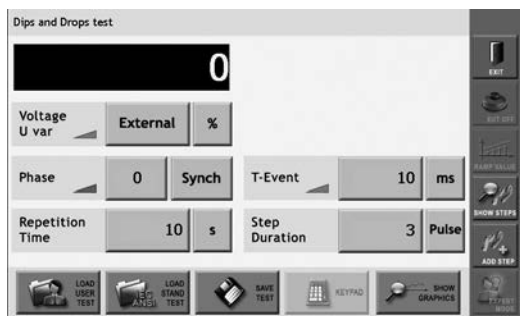

14.3.3 Manual step transformer: INA 6502

The step transformer type INA 6502 is a standard accessory for the Schaffner NSG 3040 instrumentation series. It provides a convenient means of reducing the incoming supply voltage by pre-set amounts. It is required for power quality testing (PQT) and is fully compliant with the latest revision of IEC 61000-4-11 (2004).



Its control is fully automatic, driven from NSG 3040. Once detected by the NSG 3040 and declared to the functions offered by INA 6502 are available in the software.

- 1) Connect INA 6501 - EUT power out to NSG 3040 - EUT power input
- 2) Connect INA 6501 - EUT power in to mains using EUT power in cable (delivered with NSG 3040)
- 3) Connect this connector to X2 of INA 6502

So the settings 0% - 40% - 70% - 80% will appear, as well as the possibility to switch EUT power on/off.

INA 6502 comes fitted with carrying handles as part of its overall good ergonomic design, which makes for ease of handling. Further, the unit may be used in any of two operating positions; laying on a work bench, or for more permanent applications, it can be wall-mounted.

NSG 3040 EMC test system

The unit has been designed for use in rugged industrial environments. Professional quality connectors ensure user safety, additional system protection is provided by a 16 A fuse located in the top panel.

Thanks to the provision of an 80% voltage position and to the large over current capabilities the step transformer is fully compliant with the latest requirements called for in IEC 61000-4-11:2004 standard.



For proper operation of the plug and play detection mechanisms it is strongly recommended to power on first the INA 6502 accessory and then the NSG 3040. Powering on the NSG 3040 main frame before the accessories may result in non-detection of accessories.

Operation

The parameter field voltage U_{var} gets active once an INA 6502 has been detected by the software. The entry of U_{in} is by default 230 V and may be set to other voltages, this can be done in the system/general windows. U_{var} can be selected for one of the 4 available variable voltage levels: 0% - 40% - 70% - 80%

Circuit diagram INA 6502

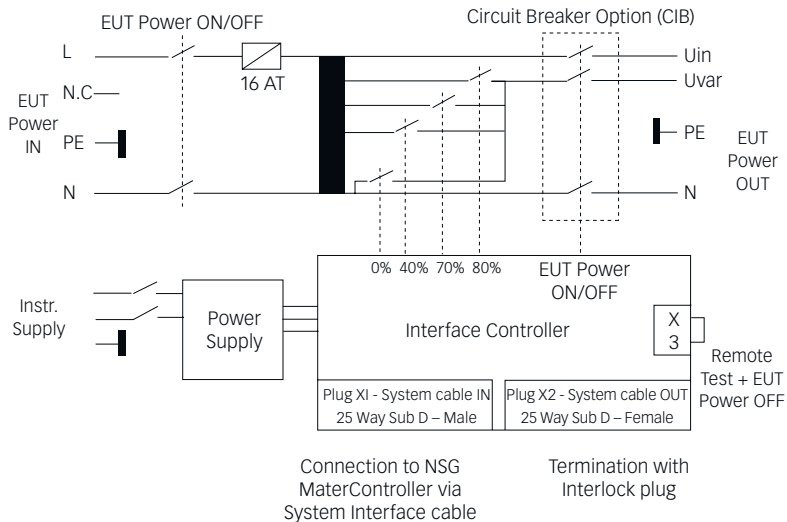

Technical specifications INA 6502

| | |
|---|---|
| Input voltage: | 0 to 250 VAC (not suited for DC voltages) |
| Output voltage: | 4 steps: 0, 40, 70, 80% |
| Accuracy: | ± 5% |
| Voltage change with load: | |
| 100% output , 0 to 16 A | less than 5% |
| 80% output, 0 to 20 A | less than 5% |
| 70% output, 0 to 23 A | less than 5% |
| 40% output, 0 to 40 A | less than 5% |
| Output current capability at 230 V input voltage: | 16 Arms at 100% output 20 Arms at 80% output 23 Arms at 70% output 40 Arms at 40% output |
| Voltage selection: | Software driven |
| EUT power on/off function: | Front panel switch with on indicator software driven from NSG 3040 |
| Fuse: | 16 A, slow blow |
| Connectors: | Harting type HAN3A |
| Power Supply: | Selectable 100-110 V, 220-240 V, 15 VA |
| Size: | 460 x 200 x 160 mm |
| Weight: | 15 kg approx. |
| Output cable length: | 2 meter |
| Input cable: | NSG 3000 standard cable to be used |
| Control cable: | 2 meter - 25 way sub D - twisted pair - shielded (included in delivery) |

Parts description

Plug X3: Remote TEST and EUT power off: with shorting plug. Allows to connect external door switch or equivalent. Interrupts the 24 V supply of the circuit breaker contactor which switches EUT supply on/off.

The information will be transmitted to NSG 3040 which will stop the test.

Plug X2: NSG 3040 system interface OUT – to be terminated by interlock plug or to be linked to another accessory, to X1 plug.

NSG 3040 EMC test system

Plug X1: NSG 3040 system interface IN – to be connected to NSG 3040 or to another accessory, to X2 plug.

Power LED (green) shows if instrument is powered up

Error LED (red)

ERROR LED off: No problem - accessory is ready to run

ERROR LED blinking: Problem which may be solved by user intervention. Ex: Interlock is activated - emergency button is pressed – overtemperature (for MFO 6502).

ERROR LED on: Problem which needs module repair – please contact your nearest Teseq customer support center or sales representative.

Installation - connection to NSG 3040



The equipment should be switched off during installation and interconnection.

- 1) Verify the setting of input voltage selector and adjust it to the right mains voltage value if required
- 2) Connect instrument power from the mains
- 3) Remove 25 way Sub D plug at rear of NSG 3040
- 4) Connect this connector to X2 of INA 6502
- 5) Connect master controller 25 way output to INA 6502 X1 plug, using system interface cable delivered with INA 6502
- 6) Connect INA 6502 - EUT power out to NSG 3040 – EUT power input
- 7) Connect INA 6502 - EUT power in to mains using EUT power in cable delivered with NSG 3040



Because of the capacitors in the internal coupler of NSG 3040, earth leakage currents of up to 4 A can occur in the EUT power supply network. The test system must therefore be correctly earthed and be powered from a supply that is not protected by a residual current detector (RCD).

- 1) Switch on INA 6502 first
- 2) Switch on the NSG 3040
- 3) Switch on EUT power (red switch) when power for the EUT is required.

HW Detection

The INA 6502 is automatically detected by the NSG 3040 during the booting process. Its presence is visualised in the system settings screen.

| Equipment details | | | | |
|-------------------|----------------|-------------|-------------------|-------------------|
| Module Name | FW Version | Serial No. | 1. Cal. Date | Last Cal. Date |
| CWM 3450 | 0002.11 | 172 | 22.2.2009 | 13.2.2009 |
| FTM 3425 | 0002.11 | 73 | 19.11.2010 | 19.11.2010 |
| INA 6502 | 0002.10 | 4267 | 23.11.2009 | 14.2.2011 |

Operation

The parameter Field **Voltage Uvar** gets active once an INA 6502 has been detected by the software. The entry of **Uin** is by default 230 V and may be set to other voltages, this can be done in the **system/general** windows. **Uvar** can be selected for one of the 4 available variable voltage levels: 0% - 40% - 70% - 80% .

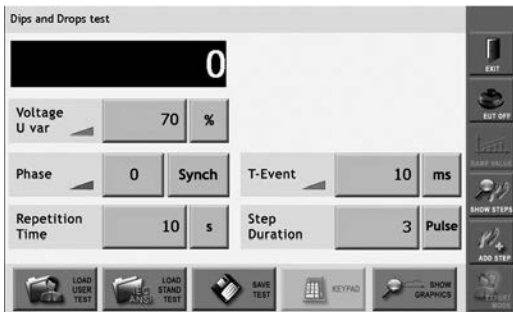

14.4 Magnetic field options

Magnetic fields at mains frequency

Mains frequency magnetic fields simulate the kind of stray fields that occur around current carrying power supply lines.

NSG 3040 together with MFO 6501 or MFO 6502 current sources generates these test conditions in accordance with the IEC 61000-4-8 standard by inducing a current into a magnetic field loop. The magnetic field produced is proportional to the current within the loop parameters. IEC 61000-4-8 specifies a clean sine wave to be used (THD <8%). This is met thanks to the use of a synthetic signal generator together with an audio current amplifier. Other advantage of this solution is that both 50 and 60 Hz fields can be generated by the same instrument.

Pulsed magnetic fields

Tests with pulsed magnetic fields simulate the type of field produced surge pulses such as those occurring during lightning strokes on buildings and other metallic structures such as free-standing masts, lightning conductors, earth networks, etc.

NSG 3040 generates these test signals in accordance with the IEC 61000-4-9 standard by inducing a current (generated by the surge module CWM 3450) into magnetic field loop in which the magnetic field produced in proportional to the current within the loop parameters.



It is recommended for the user to stay away (at least a few meters) from the loop antenna while magnetic fields are generated. Also keep away magnetic field sensitive devices and items such as credit cards – magnetic key cards etc... which might be influenced by the field.

Magnetic field loops INA 701, 702 and INA 703

Tests with mains frequency and pulsed magnetic fields are performed using the magnetic field loops designed for NSG 3040. These are rectangular loops measuring 1 x 1 m and are suitable for test objects with dimensions up to 0.6 x 0.6 x 0.5 m (l x w x h).

Three types of loop can be supplied:

INA 701

The INA 701 is a 1 x 1 m loop – single turn - with a coil factor of 0.89. It enables the generation of field strengths of up to 3.6 A/m for mains frequency fields 50 or 60 Hz when used with the MFO 6501 or MFO 6502 current sources and 1200 A/m for pulsed magnetic fields, where the current is generated by a 4400 V surge generator.



INA 702

The INA 702 is a 1 x 1 m loop - 11 turns – coil factor 9.8 - when fitted with the power plug. It enables the generation of field strengths of up to 40 A/m for mains frequency fields 50 or 60 Hz when used with the MFO 6501 or MFO 6502 current sources.

INA 702 becomes a single turn loop when fitted with the pulse plug, which allows the generation of pulsed field strengths up to 1200 A/m, where the current is generated by a 4400 V surge generator.

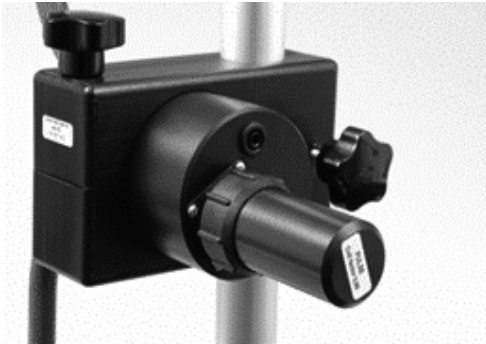

INA 703

The INA 703 was conceived for tests at stronger power frequency magnetic fields according to IEC 61000-4-8.

A multi-turn concept (37 turns) allows the INA 703 to generate fields higher than 1000 A/m while using a programmable AC source rated for just 30 A. This enables testing to the IEC 61000-4-8 standards requirement of a current THD < 8%, which can be met only with a programmable AC source.

The INA 703 has taps at turns 1 and 5, providing increased accuracy when generating low amplitude fields.

For testing to IEC 61000-4-8, the INA 703 can be used as an accessory to a TESEQ Profline system comprising an NSG 1007 source, an INA 2141 impedance box and the the WIN 2120 software.

The INA 703 can also be used with the MFO 6501 or 6502 current sources and the NSG 3000 series of generators to generate supply frequency fields (50 Hz and 60 Hz) over 120 A/m continuously.

With its multi-turn concept and professional mechanical design features, such as the U-shaped castor base for convenient positioning at the test table, the INA 703 is the ideal accessory for magnetic field testing.

In order to meet the pulse waveform required by IEC 61000-4-9, the waveshape adapter INA 752 needs to be used with NSG 3040 and the INA 701 and INA 702 loop antennas.



The tests are carried out using the so-called immersion method, i.e. the item under test is placed in the center of the loop. The test is performed in accordance with the IEC 61000-4-8 (mains frequency) or IEC 61000-4-9 (pulsed) standards for magnetic fields.

14.4.1 Manual solution: MFO 6501

The manually operated current generator type MFO 6501 (magnetic field option) is a standard accessory for the Teseq NSG 3040 series. It provides a convenient means for generating and adjusting the current to flow through one of the magnetic field loops INA 701 or INA 702. It is required for magnetic field testing for fields up to 40 A/m. It complies to the requirements of IEC 61000-4-8.



MFO 6501 can be used as a stand alone. It is fitted with carrying handles as part of its overall good ergonomic design, which makes for ease of handling. Further, the unit may be used in any of three operating positions; laying or standing on a work bench, or for more permanent applications, it can be wall mounted.



Care has to be taken is case of use in standing position, as the stability is limited, so the cabling connecting MFO 6501 to mains and Modula presents a risk of being unvoluntarily caught by the users causing the MFO 6501 to fall down.

The few control elements are readily accessible on the front panel. A rotary knob to set the necessary current, a 50/60 Hz frequency selector and a low/high range selector ensure easy and intuitive operation.

Two safety banana sockets provide a convenient means to connect the loop antenna, two other ones (shorted by a jumper) to connect an external amp-meter for monitoring the generated current, as the field generated in the loop antenna is directly proportional to the current flowing through it:

Field strength (A/m) $H = C_f \times I$

Where H is the generated field, C_f the coil factor, I the current flowing through the loop.

The unit has been designed for use in rugged industrial environments. Professional quality connectors ensure user safety, additional system protection is provided by a temperature sensor located on the heatsink of the power amplifier.



MFO 6501 is designed to drive INDUCTIVE LOADS ONLY, as magnetic field loops.

■ Connecting capacitive loads will destroy the Instrument

Circuit diagram MFO 6501

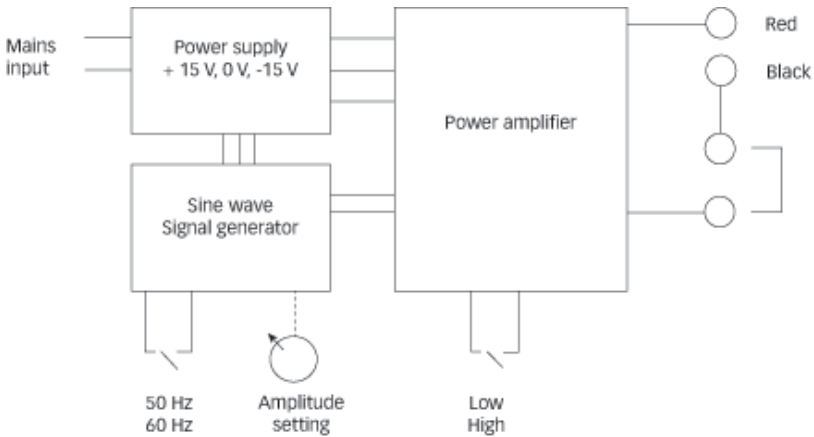

| Parameter | Value |
|-----------------------------------|--|
| Total harmonic distortion (THD)*: | < 8% (nominal <3,5% at full range) |
| Frequency: | Selectable 50 and 60 Hz +/- 3% |
| Range low**: | 80 to 400 mA into INA 702 (Cf = 9.8) => allows 0.8 to 4 A/m 80 to 440 mA into INA 701 (Cf = 0.89) => allows 0.08 to 0.4 A/m INTO INA 703 |
| Range high**: | 200 mA to 4.1 A into INA 702 (Cf = 9.8) => allows 2 - 40 A/m 200 mA to 4.1 A Into INA 701 (Cf = 0.89) => allows 0.2 – 3.6 A/m |
| Supply voltage: | 90 to 240 V |
| Power consumption: | < 150 W |
| Operating temperature: | 5° – 40°C |
| Overload protection: | By temperature sensor on power stage |
| Weight: | 4 kg approx. |
| Dimensions: | 195 x 180 x 380 mm |

*** Typical, for the full range from standard level 1 (lowest standard level) to full range (level X)**

**** Current adjustment through customer provided amp-meter.**

Installation



The equipment should be switched off during installation and interconnection.

- 1) Connect MFO 6501 to INA 701, 702 or 703 loop
- 2) In case of use of INA 702 insure that "power" plug is fitted
- 3) Connect MFO 6501 to mains
- 4) Connect external amp-meter
- 5) Switch on mains power
- 6) Adjust the required current through the loop using the knob



Operation - adjustments

The field generated in the loop antenna is directly proportional to the current flowing through it:

Field strength (A/m) $H = C_f \times I$

Where H is the generated field, C_f the coil factor, I the current flowing through the loop.

Please refer to following table for test level adjustment.

| Standart level | Field in the loop A/m | Current re-quired for INA 701 $C_f = 0.89$ | Current required for INA 702 (power) $C_f = 9.8$ | Current re-quired for INA 703 $C_f = 34$ |
|----------------|-----------------------|--|--|--|
| 1 | 1 | 1.12 | 0.102 | 0.029 |
| 2 | 3 | 3.37 | 0.306 | 0.088 |
| 3 | 10 | N/A | 1.02 | 0.294 |
| 4 | 30 | N/A | 3.06 | 0.882 |
| x | 40 | N/A | 4.08 | 1.176 |
| x | 120 | N/A | N/A | 3.53 |

Use the external amp-meter to adjust the required current

14.4.2 Automatic solution: MFO 6502

The automatic current generator type MFO 6502 (magnetic field option) is a standard accessory for the NSG 3040 series. It provides a convenient means of generating and regulating the current to flow through one of the magnetic field loops INA 701, INA 702 or INA 703. It is required for magnetic field testing for fields up to 40 A/m. It complies to the requirements of IEC 61000-4-8.



It is fitted with carrying handles as part of its overall good ergonomic design, which makes for ease of handling. Further, the unit may be used in any of two operating positions; laying on a work bench, or for more permanent applications, it can be wall mounted.

Its control is fully automatic, driven from NSG 3040. Once detected by the NSG 3040, the functions offered by MFO 6502 are available in the software. Following icon will be darkened showing the functions are active:



The coil factor of the used loop antenna is to be entered in the respective field, then the user will setup his tests directly in A/m, the software makes the calculation and drives the MFO 6502 to generate the right current through the loop antenna.

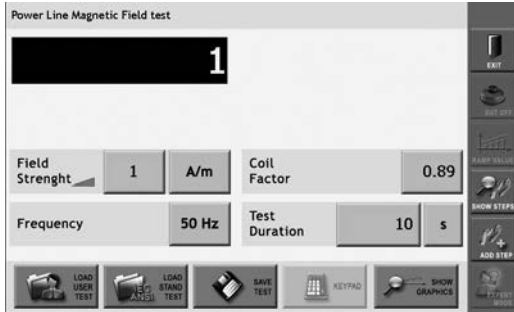

Two safety banana sockets (red and black) provide a convenient means to connect the loop antenna, two other ones (green - shorted by jumper) to connect an external amp-meter for verifying (or to calibrate) the generated current, as the field generated in the loop antenna is directly proportional to the current flowing through it:

Field strength (A/m) $H = C_f \times I$

Where H is the generated field, C_f the coil factor, I the current flowing through the loop.

The unit has been designed for use in rugged industrial environments. Professional quality connectors ensure user safety, additional system protection is provided by a temperature sensor located on the heatsink of the power amplifier.



MFO 6502 is designed to drive INDUCTIVE LOADS ONLY, as magnetic field loops.

- Connecting capacitive loads will destroy the Instrument



For proper operation of the plug and play detection mechanisms it is strongly recommended to power on first the MFO 6502 accessory and then the NSG 3040.

Powering on the NSG 3040 before the accessories may result in a non detection of the accessories.

Circuit diagram MFO 6502

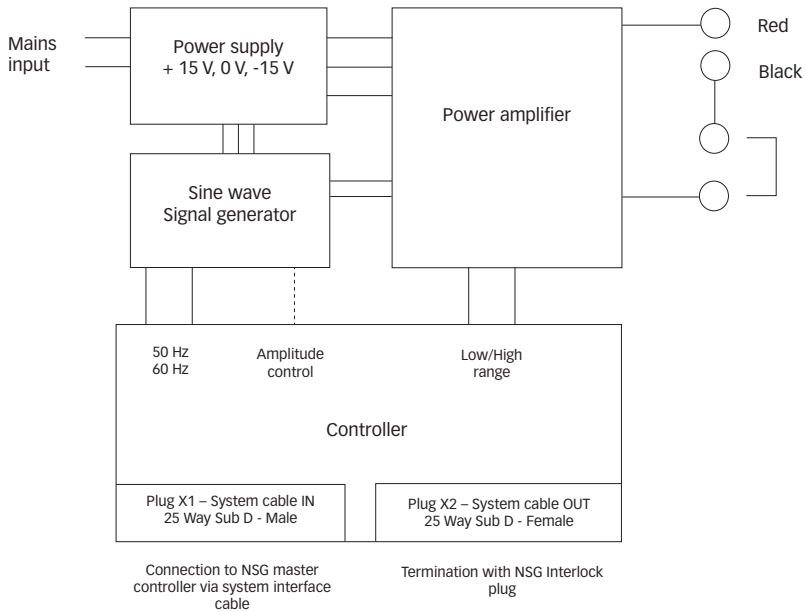

Technical specifications MFO 6502

| Parameter | Value |
|-----------------------------------|---|
| Total harmonic distortion (THD)*: | < 8% (nominal <3,5% at full range) |
| Frequency: | Selectable 50 and 60 Hz +/- 3% |
| Magnetic field adjustment: | Software driven |
| Range low**: | 80 to 400 mA into INA 702 (Cf = 9.8) => allows 0.8 to 4 A/m 80 to 440 mA into INA 701 (Cf = 0.89) => allows 0.08 to 0.4 A/m INTO INA 703 ... |
| Range high**: | 200 mA to 4.1 A into INA 702 (Cf = 9.8) => allows 2 - 40 A/m 200 mA to 4.1 A Into INA 701 (Cf = 0.89) => allows 0.2 – 3.6 A/m |
| Supply voltage: | 90 to 240 V |
| Power consumption: | < 150 W |
| Operating temperature: | 5° – 40°C |
| Overload protection: | By temperature sensor on power stage |
| Weight: | 4.2 kg approx. |
| Dimensions: | 195 x 180 x 380 mm |
| Control cable: | 2 meter - 25 way sub D - twisted pair - shielded (incl. in delivery) |

*** Typical, for the full range from standard level 1 (lowest standard level) to full range (level X)**

**** Current adjustment through customer provided amp-meter.**



Indicated max values reachable for environmental temperatures below 30° C. For higher environment temperatures internal temperature sensor might trip after a few minutes.

Power LED (green) shows if instrument is powered up

Error LED (red)

ERROR LED off: No problem - accessory is ready to run

ERROR LED blinking: Problem able to be solved by user. Ex.: Interlock is activated – emergency

button is pressed – overtemperature

ERROR LED on: Problem which needs module repair – please contact your nearest Teseq customer support center or sales representative.



The equipment should be switched off during installation and interconnection.

Installation - connection to NSG 3040

- 1) Connect instrument power in to mains
- 2) Remove 25 way Sub D plug at rear of NSG 3040
- 3) Connect this connector to X2 of MFO 6502
- 4) Connect NSG 3040 25 way output to MFO 6502 X1 plug, using system interface cable delivered with MFO 6502
- 5) Connect MFO 6502 to loop antenna INA 701, 702 or 703
- 6) In case of INA 702, verify that “Power” plug is fitted to the coil interface unit
- 7) Power on MFO 6502
- 8) Power on NSG 3040 main frame

Operation

The coil factor is given by the loop antenna manufacturer. For Teseq INA 701, 702 and INA 703 loop antennas this factor is labelled on the antenna and is also indicated in the test report delivered with it.

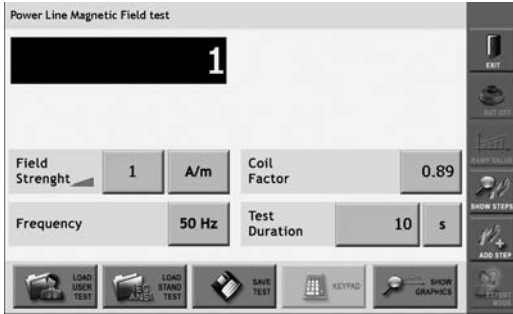

14.5 Pulse wave shape adapter INA 752

The pulse waveshape adapter INA 752 is a standard accessory for the Teseq NSG 3000 series. It provides a convenient means for interconnecting the NSG 3040 surge generator with the loop antennas INA 701 or 702 and insures that the generated pulsed magnetic field has the waveshape as specified in the application standard.

The combination NSG 3040 with CWM 3450 – INA 752 – INA 701 (or 702) is required for magnetic field testing for pulsed fields up to 1200 A/m. It complies to the requirements of IEC 61000-4-9.

The control is fully automatic, driven from NSG 3040. Click on following icon:



Following test screen will appear:

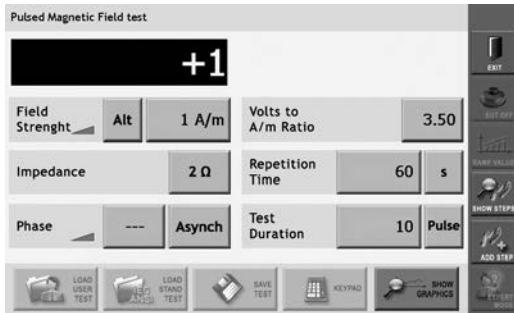

Once the right Volts to A/m ratio – which is available on the INA 752 as well then in its calibration certificate is entered in its respective field, the user will be able to enter the required test level directly in A/m – no need for him to proceed with calculations, the instrument software does the job.



In case an INA 702 loop antenna is used, the termination plug labelled "Pulse" needs to be used.

Technical specifications NSG 3040 (CWM 3450) - INA 752 - INA 701/INA 702

| Parameter | Value |
|----------------------------|--|
| Volts to A/m ratio*: | 3.55 |
| Magnetic field adjustment: | Software driven, NSG 3040 settings 200 to 4400 V => allows 60 to 1200 A/m |
| INA 752 weight: | 0.6 kg |
| INA 752 dimensions: | 140 x 75 x 55 mm |

* Typical, exact value is given on INA 752 front panel

14.6 Coupling decoupling networks for data lines

14.6.1 Burst EFT coupling clamp NSG 3425 - and safety cover INA 3825

The EFT/bursts coupling clamp CDN 3425 is designed for the injection of fast transients into signal and data lines as specified in basic standard IEC 61000-4-4.



The EFT/bursts coupling clamp CDN 3425 is to be used with a IEC 61000-4-4 compliant EFT/burst generator.

The IEC/EN 61000-4-4 standard also permits the capacitive coupling method to be used for pulse injection into AC and DC power supply cables when no suitable decoupling network is present.

The coupling capacitance between the coupling clamp and the cable laid in it depends on the type of cable, its diameter and various other factors such as screening, etc.

The option INA 3825 – Safety cover with Interlock is available which avoids the user to touch the conductive plate of the CDN 3425 while EFT/burst pulses get applied.

Preparation for operation

The test rig is to be constructed in accordance with IEC/EN 61000-4-4 with special reference to:

Operation preferably in a screened room to protect the environment
Distances to the EUT and peripherals to be as specified in the standard.
Good and large area contact to the earth plane. Tests on uninsulated cables is not permissible.

Operation

Connect the delivered HV pulse cable to the pulse output of the used EFT/burst generator.



If INA 3825 accessory is used, connect the Interlock cable to the interlock input of your generator, use the INA 3825 to cover the CDN 3425 the way the interlock switch (rear side – middle) gets activated.

Start the EFT/burst test. Follow instructions of EFT/burst generator user manual.

Mechanical parameters CDN 3425

| Parameter | Value |
|-----------|----------------|
| Length: | 1100 mm |
| Width: | 200 mm |
| Height: | 110 mm |
| Weight: | 7.5 kg approx. |

Mechanical parameters INA 3825

| Parameter | Value |
|-----------|----------------|
| Length: | 1230 mm |
| Width: | 250 mm |
| Height: | 170 mm |
| Weight: | 3.5 kg approx. |

Electrical parameters of the clamp

Max. permissible burst voltage 8 kV

| Parameter | Value |
|--|---|
| Usable length of the clamp: | 1100 mm |
| Diameter of the test cable: | 4 to 40 mm |
| Connectors: | SHV-NIM female, 50 Ω on both ends) |
| Distance of the earth reference plane: | 100 mm |

When used together with a burst EFT generator for more than 4 kV, it is recommended to cover the CDN 3425 with the INA 3825 cover with interlock, and to connect the foreseen interlock cable of INA 3825 to the interlock input of the EFT/burst generator.

This way the user is protected from touching the CDN 3425 coupling plate when EFT/burst pulses are applied.



CDN 3425 with INA 3825 protection cover

NSG 3040 EMC test system

14.6.2 Surge CDN for unsymmetric datalines CDN 117

Teseq's CDN 117 coupling-decoupling network enables convenient testing with surge pulses of 1.2/50 μ s on data, signal or peripheral lines, as specified in many product standards. The test method, severity levels, permissible reaction of the EUT and specification of the coupling networks are included in IEC/EN 61000-4-5.



All coupling methods described in IEC/EN 61000-4-5 for unshielded unsymmetrical line pairs can be performed both in differential- and common mode coupling (line-to line and line-to-ground).

The user can manually select coupling modes by connecting the surge generator's output to the appropriate input of the CDN 117.

Several CDN 117s can be arranged in parallel for applications in which more than two conductors must be decoupled.

The CDN 117 can be easily interfaced with the EUT and is designed as a bench top unit. It can be used with Teseq's NSG series or any industry standard surge generator with the appropriate connector adapter.

Technical specifications

| Signal line | |
|----------------------------|--|
| Max. operating voltage: | AC 250 V DC 250 V |
| Max. operating current: | 1.5 A |
| Ohmic resistamce per path: | 2.5 Ω |
| Decoupling chokes 1 KHz: | 20 mH nominal |
| Pulse: | 1.2/50 μ s pulse |
| Max. pulse voltage: | 6.6 kV |
| Accessories: | |
| Series resistor: | 2 x 40 Ω , 6 W |
| Coupling adapters: | INA 170 Sparkling gap device, 90 V trip voltage |
| | INA 171 Capacity 0.1 μ F//spark gap device, 90 V trip voltage |
| | INA 174 Capacitor 0.5 μ F |

14.6.3 Surge pulse CDN for symmetric datalines CDN 118

Teseq's CDN 118 coupling-decoupling network is designed for convenient surge testing of telecommunications equipment to IEC/EN 61000-4-5, which specifies a 1.2/50 or a 10/700 μ s pulse.

The CDN 118 includes the special decoupling network and coupling elements that are required for these tests.

The CDN 118 can be easily interfaced with the EUT and is designed as a bench top unit. It can be used with Teseq's NSG series or any industry standard surge generator with the appropriate connector adapter.



Technical specifications

| Parameter | Value |
|----------------------------|--|
| Max. operating voltage: | AC 250 V DC 250 V |
| Max. operating current: | 0.5 A |
| Ohmic resistance per path: | 3 Ω |
| Decoupling chokes 1 KHz: | 20 mH nominal |
| Pulse: | 1.2/50 and 10/700 μ s pulse |
| Max. pulse voltage: | 6.6 kV line to ground, 3 kV line to line |
| Accessories: | |
| Resistor networks: | INA 172 4 x 100 Ω , 6 W INA 175 4 x 160 Ω , 6 W |
| Coupling adapters: | INA 170 Sparkling gap device, 90 V trip voltage INA 171 Capacity 0.1 μ F/spark gap device, 90 V trip voltage INA 173 Short circuit connector |

14.7 Measuring accessories

14.7.1 MD 200 and MD 200A differential high voltage probes

The Teseq MD 200 and MD 200A high voltage differential probes are ideally suited to allow EMC engineers to verify their conducted EMC test generators periodically. Their performance permits to be used for many other purposes where higher voltages have to be measured in a potential free manner.

Annual calibration and periodic verification

The annual calibration of test equipment recommended by most of the quality systems (ISO 9000, ISO 17025, etc.) has to be considered as a validation of all measurements done since the last calibration.

Many EMC standards call for a verification of the test equipment before and after every test session. If the verification shows differing results, no valid test results can be assumed and the test equipment has to be re-calibrated. It is therefore highly recommended that the EMC test engineer periodically verifies his test equipment in order to ensure good functionality and accuracy.

Periodic verification can be done before a test session or once a day or week or month; it is up to the user to decide. Only a few points need to be checked, which will take only a few minutes if the right test equipment is available.

Potential free (differential) measurements

Since it may be useful to measure pulses superimposed on the mains for periodic verification purposes, it is essential to work with differential measurements. Using classic non-differential probes and connecting with reversed polarity will result in the oscilloscope chassis being connected to the mains. In the best case a circuit breaker will trip, in the worst case, for example if the oscilloscope is battery powered or supplied via an isolation transformer, the oscilloscope chassis will be at a voltage equal to mains voltage plus the peak pulse voltage, which could be lethal for the user. The Teseq high voltage differential probe MD 200 series is ideally suited to measure all kinds of EMI pulses in the microsecond range, industrial, telecom and automotive surges as well as power line dips, interrupts and distortions.



MD 200



MD 200A

Technical specifications MD 200

| | |
|------------------------------------|---------------------------------------|
| Attenuation ratio: | 2 ranges: 1:100 and 1:1000 |
| Bandwidth: | DC to 10 MHz |
| Accuracy: | +/-2% |
| Max. input voltage different mode: | 7000 V peak |
| Max. input voltage common mode: | 3500 V peak |
| Input impedance: | 10 M Ω /7 pF each side ground |
| CMRR (typical): | -80 dB at 50 Hz; -60 dB at 20 kHz |
| Operating temperature: | -10° to + 40C° (14° to 104° F) |
| Dimensions (LxWxH): | 207 x 83 x 38 mm (8.1 x 0.32 x 0.15") |
| Connector to scope: | BNC and auxiliary earth lead |
| Input connectors: | HV alligator clip |
| Weight: | 500 g approx. (1.1 lbs) |

Technical specifications MD 200A

| | |
|------------------------------------|--------------------------------------|
| Attenuation ratio: | 2 ranges: 1:100 and 1:1000 |
| Bandwidth: | DC to 10 MHz |
| Accuracy: | +/-2% |
| Max. input voltage different mode: | 7000 V peak |
| Max. input voltage common mode: | 7000 V peak |
| Input impedance: | 10 M Ω /7 pF each side ground |

| | |
|------------------------|---------------------------------------|
| Input impedance: | 10 M Ω /7 pF each side ground |
| CMRR (typical): | -80 dB at 50 Hz; -60 dB at 20 kHz |
| Operating temperature: | -10° to + 40 C° (14° to 104° F) |
| Dimensions (LxWxH): | 207 x 83 x 38 mm (8.1 x 0.32 x 0.15") |
| Connector to scope: | BNC and auxiliary earth lead |
| Input connectors: | HV alligator clip |
| Weight: | 500 g approx. (1.1 lbs) |

14.7.2 MD 300 surge pulse current probe set

The MD 300 probe has been specially designed to verify surge current pulses as specified in IEC/EN 61000-4-5, ANSI C62.41 and their derivatives.



The main advantage of the MD 300 current probe is, that the measuring system is physically isolated from the circuit under test.

The MD 300 current probe is ready to use as coming along with pre-mounted coaxial cable. The BNC-end plug needs to be connected to the high-impedance input or 50 Ω input of an ordinary memory oscilloscope. Then the conductor carrying the surge current to be measured is passed through the hole in the current probe. The resulting voltage wave shape on the oscilloscope will then be an authentically reproduction of the actual current wave shape within the given accuracy.

NSG 3040 EMC test system

The probe can be used for current pulse verification on surge generators. Optional FISCHER or LEMO connectors are available for matching the safety banana connectors of the shorting cable to the HV output of the generator. For monitoring the EUT current during a test, an additional IEC adaptor with the safety banana connectors can be connected to the generator EUT output for observation of one lead at a time.

Technical specifications

| | |
|---|--|
| Max. peak. current | 5000 Amp |
| Max. RMS current: | >63 Amp |
| Nominal ratio: | 500:1 (into 1 M Ω system) 1000:1 (into 50 Ω system) |
| Sensitivity: | 0.002 V/Amp (M Ω system) 0.001 V/Amp (Ω system) |
| Hole diameter: | 8 mm |
| Probe connector: | SMA |
| Scope coax cable: | with SMA and BNC connectors |
| Operating temperature: | 0 to 55°C |
| Output impedance: | 50 Ω |
| Accuracy: | < \pm 2% |
| MD 300 set: | Carry case, current probe, coax cable with SMA/BNC connector, shorting cable with safety banana connectors, calibration certificate, user manual |
| Options | |
| INA 6560: | FISCHER to banana plug adaptor set |
| INA 2042: | LEMO to banana plug adaptor set |
| INA 6554: | IEC 320 single phase to safety banana adaptor leads 2 x 155-131 6 to 4 mm adaptors with safety banana connectors |
| Note: The carry case provides spare place for all options | |

14.7.3 MD 310 SOW pulse current probe set

The MD 310 probe is specially adapted to verify Damped Oscillatory Wave current pulses as specified in IEC/EN 61000-4-18 or ANSI/IEEE C37.90.1 and their derivatives.

The main advantage of the MD 310 current probe is, that the measuring system is physically isolated from the circuit under test.

The MD 310 current probe is ready to use. It comes with a pre-mounted coaxial cable as well as the conductor carrying the SOW current to be measured. The BNC-end plug needs to be connected to the high-impedance input or 50 Ω input of an ordinary memory oscilloscope. Then the conductor carrying the SOW current to be measured needs to be connected between the EUT supply. The resulting voltage wave shape on the oscilloscope will then be an authentically reproduction of the actual current wave shape within the given accuracy.

Optional FISCHER connectors are available for matching the safety banana connectors of the shorting cable to the HV output of the generator. For monitoring the EUT current during a test, an additional IEC adaptor with the safety banana connectors can be connected to the generator EUT output for observation of one lead at a time.

| Parameter | Value |
|---|--|
| Max. peak current: | 400 Amp |
| Max. RMS current: | 10 Amp |
| Nominal ratio: | 10:1 (into 1 M Ω system) 20:1 (into 50 Ω system) |
| Sensitivity: | 0.1 V/Amp (1 M Ω system) 0.05 V/Amp (50 Ω system) |
| Hole diameter: | 6.3 mm |
| Probe connector: | SMA |
| Scope coax cable: | with SMA and BNC |
| Operating temperature: | 0 to 65°C |
| Output impedance: | 50 Ω |
| Accuracy: | +1%/-0% |
| MD 310 set: | Carry case, current probe, coax cable with SMA/BNC connector, shorting cable with safety banana connectors, calibration certificate, user manual |
| Options | |
| INA 6560 | FISCHER to banana plug adaptor set |
| INA 2042: | LEMO to banana plug adaptor set |
| INA 6554: | IEC 320 single phase to safety banana adaptor leads 2 x 155-131 6 to 4 mm adaptors with safety banana connectors |
| Note: The carry case provides spare place for all options | |

14.7.4 Burst/EFT pulse verification kit

The Teseq CAS 3025 burst/EFT pulse verification kit has been specially designed to comply with the new requirements of IEC/EN 61000-4-4:2004 to enable EMC engineers to verify their burst/EFT test generators periodically.

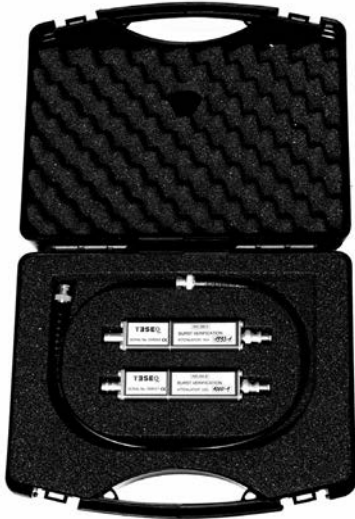

Annual calibration and periodic verification

The annual calibration of test equipment recommended by most quality systems (ISO 9000, ISO 17025, etc.) has to be considered as a validation of all measurements done since the last calibration.

Many EMC standards call for a verification of the test equipment before and after every test session. If the verification shows differing results, no valid test results can be assumed and the test equipment has to be re-calibrated.

It is therefore highly recommended that the EMC test engineer periodically verifies his test equipment in order to ensure good functionality and accuracy

NSG 3040 EMC test system

and hence minimise the risk of bad measurements and the need for a product re-call. Periodic verification can be done before a test session or once a day

or week or month; this is up to the user to decide. Only a few points need to be checked, which will take only a few minutes if the right test equipment is available.

The Teseq CAS 3025 comprises two termination attenuators INA 265B and INA 266A – plus a coaxial RG58 cable and calibration certificate indicating the precise ratio. The whole is delivered in a handy case.

Technical specifications

| | |
|---|------------------------|
| INA 265B termination/attenuation (typical): | 50 Ω , 1:1000 |
| INA 266A termination/attenuation (typical): | 1000 Ω , 1:2000 |
| Bandwidth: | 400 MHz |
| Max. input burst peak voltage: | 8800 V peak |
| Operating temperature: | -10 to +40° C |
| Dimensions (LxWxH): | 280 x 230 x 85 mm |
| Weight: | 900 g approx. |

14.8 Cables, plugs and adapters

14.8.1 Calibration adapters



**INA 3237
(former INA 6561)**

BURST/EFT calibration adapter to connect NSG 3040 and CDN 3061 series (second edition and later) to calibration terminator/attenuator CAS 3025.



INA 3236
(former INA 6560)

HV-plug adapter set for NSG 3000 series
- Surge out to safety Banana, 1 plug to RED banana, 1 plug to Black banana. Required for surge pulse calibration (safe and reliable connection to measuring probes - Max applicable surge voltage is 10 kV). Can also be used to build injection probe to couple surge pulses to shielded datalines and EUT's housings, etc...



INA 3233
(former INA 6554)

Adapter IEC 320 to banana plugs. To connect EUT with banana plugs to NSG 3040 or CDN 3061 series.

14.8.2 Test adapters



INA 3230
(former INA 6550)

Adapter IEC 320 to Schuko plug. To connect EUT with Schuko plugs to NSG 3040 or CDN 3061 series.



INA 3231
(former INA 6551)

Adapter IEC 320 to Swiss plug. To connect EUT with Swiss plug to NSG 3040 or CDN 3061 series.



**INA 3232
(former INA 6555)**

Adapter IEC 320 to French plug. To connect EUT with French plugs to NSG 3040 or CDN 3061 series.

14.8.3 Various cables and plugs



INA 6542

EUT power IN cable for NSG 3000 series and accessories.



INA 6543

Mains plug adapter for EUT connection to NSG 3040 and CDN 3061 series.



INA 6544

HV-plug set (surge out) for NSG 3000 series for cable diameter 10.3 mm. Can be used for connection to external CDN, or to make an injection probe to couple surge pulses to shielded datalines and EUT's housings.

**INA 6545**

HV-plug set (surge out) for NSG 3000 series for cable diameter 5.1 mm. Can be used for connection to external CDN, or to make an injection probe to couple surge pulses to shielded datalines and EUT's housings.

**INA 6546**

SHV plug (burst out) for all Schaffner Teseq Burst generators, Burst CDNs and coupling clamps. For cable diameter 5.1 mm (typical RG 58 or INA 6547 or INA 6548).

**INA 6547**

20 kV coax cable, length 1 m. To be used together with INA 6545, for connection to external CDN, or to make an injection probe to couple surge pulses to shielded datalines and EUT's housings.

**INA 6548**

20 kV coax cable, length 5 m. To be used together with INA 6545, for connection to external CDN, or to make an injection probe to couple surge pulses to shielded datalines and EUT's housings.

**INA 6556**

DC supply adapter. Consists of EUT Power IN cable fitted with safety banana plugs at the other end. For NSG 3000 series.

14.9 Mounting accessories

153



INA 3000

Trolley for NSG 3000 series. Convenient accessory to get standalone instruments stacked and mobile through large castors. Static load <150 kg.



INA 166

Rack mounting brackets (4 HU) for NSG 3040 series.

15 SYSTEM DESCRIPTION



Dimensions NSG 3040: 449 (17.7") x 226 (8.9"; 5 HU) x 565 mm (22.2")
(W x H x D)

Weight NSG 3040: approx. 28 kg (62 lbs)

| | | |
|---------------------------------|---|-------------|
| Description: | Test system for EMC tests with mains-borne interference in accordance with the EN 61000-6-1 and 2 standards for burst, surge and mains quality tests. Operation via touch-screen or software-wise via a PC link Ethernet TCP/IP interface. Pulse output to external coupling networks. Housing for bench-top or rack use. | |
| Housing: | Bench-top housing made of metal with moulded plastic front panel. Supplementary rack-mounting kit. | |
| Mains on/off: | On/off switch on rear panel of the instrument | |
| Indicator LED's on front panel: | Power on: | LED, yellow |
| | Pulse: | LED, green |
| | High voltage active: | LED, red |
| | EUT Power on: | LED, green |
| | Error: | LED, red |
| Safety functions: | Main fuses, interlock, EUT fail input | |
| Ambient conditions: | +5° to 40°C, 20 to 80% relative humidity (non-condensing), 68–106 kPa atmospheric pressure | |
| Self-test: | Routines for functional self-test | |
| Relevant safety standards: | IEC 61010-1 safety requirements for electrical equipment used for measurement and control purpose as well as laboratory use | |

Manufacturer

Teseq AG

4542 Luterbach, Switzerland

T +41 32 681 40 40

F +41 32 681 40 48

chsales.teseq@ametek.com

China

AMETEK Commercial Enterprise (Shanghai) Co., Ltd. Beijing Branch

T +86 10 8526 2111

F +86 10 8526 2141

chinasales@teseq.com

France

AMETEK SAS

T +33 1 30 68 89 00

F +33 1 30 68 89 99

info.france@ametek.com

Germany

Teseq GmbH

T +49 30 5659 8835

F +49 30 5659 8834

deinfo.teseq@ametek.com

Japan

AMETEK Co., Ltd. Nagoya Office

T +81 52 709 5501

F +81 52 709 5502

cts-japan.sales@ametek.co.jp

Singapore

AMETEK Singapore Pte Ltd (C/o Teseq Pte Ltd)

T +65 6484 2388

F +65 6481 6588

singaporesales@teseq.com

To find your local partner within Teseq®'s global network, please go to **www.teseq.com**

Switzerland

Teseq AG

T +41 32 681 40 40

F +41 32 681 40 48

chsales.teseq@ametek.com

Taiwan

Teseq (Taiwan) Ltd.

T +886 2 2917 8080

F +886 2 2917 2626

taiwansales@teseq.com

UK

Teseq Ltd.

T +44 845 074 0660

F +44 845 074 0656

uksales@teseq.com

USA

Teseq Inc.

T +1 732 417 0501

F +1 732 417 0511

Toll free +1 888 417 0501

usasales.cts@ametek.com

© May 2015 Teseq®

Specifications subject to change without notice. Teseq®, a unit of AMETEK Compliance Test Solutions, is an ISO-registered company. Its products are designed and manufactured under the strict quality and environmental requirements of the ISO 9001. This document has been carefully checked. However, Teseq® does not assume any liability for errors or inaccuracies.